

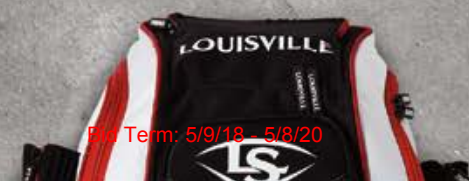

# 2018

## SPRING DEALER WORKBOOK

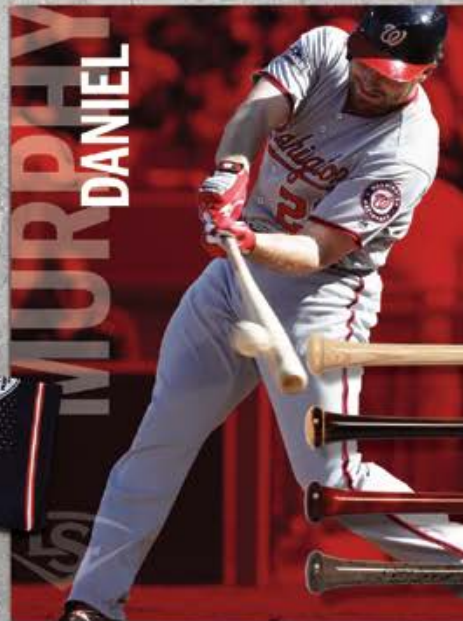





# BASES COVERED

---

EVOSHIELD® JOINS WILSON®, DEMARINI®, LOUISVILLE SLUGGER® AND ATEC® TO CREATE THE MOST COMPLETE BASEBALL EQUIPMENT PROVIDER IN THE WORLD.



WILSON®

BASEBALL GLOVES	004
FASTPITCH GLOVES	023
SLOWPITCH GLOVES	027
GLOVE CARE	028
PROTECTIVE GEAR	029
BASEBALLS & SOFTBALLS	039
GEAR BAGS	048

DEMARINI®

BASEBALL BATS	052
FASTPITCH BATS	058
SLOWPITCH BATS	062
BATTING GLOVES	066
BATTING HELMETS	069
SLOWPITCH BALLS	072
GEAR BAGS	074

LOUISVILLE SLUGGER®

BASEBALL BATS	080
WOOD BATS	086
FASTPITCH BATS	104
SLOWPITCH BATS	107
BATTING GLOVES	110
BASEBALL GLOVES	114
FASTPITCH GLOVES	118
SLOWPITCH GLOVES	120
PROTECTIVE GEAR	121
GEAR BAGS	123

EVOSHIELD®

PROTECTIVE GEAR	130
BATTING GLOVES	134
BATTING HELMETS	135
COMPRESSION	136

ATEC®

TRAINING MACHINES	143
TRAINING BALLS	149
BATTING TEES	150
PROTECTIVE SCREENS	152
TRAINING NETS	154
ACCESSORIES & PARTS	155

STOCK UNIFORMS & APPAREL

BASEBALL UNIFORMS	158
FASTPITCH UNIFORMS	165
BASEBALL TEAM APPAREL	172
EVOSHIELD BASEBALL APPAREL	176
FASTPITCH TEAM APPAREL	179
HATS & TEES	183

COMBINED PRODUCT ASSORTMENT

GLOVES FOLD OUT	
BATS FOLD OUT	
GEAR FOLD OUT	





---

**LEATHER-BORNE CONFIDENCE.** A tenacious grip on the seams. Fearless protection behind the plate and a united team hitting the diamond. Gloves, balls, protective gear and uniforms – Wilson® equipment is a natural extension of baseball and softball players everywhere. It's been like that for over sixty years and the tradition continues as players become one with Wilson in 2018.



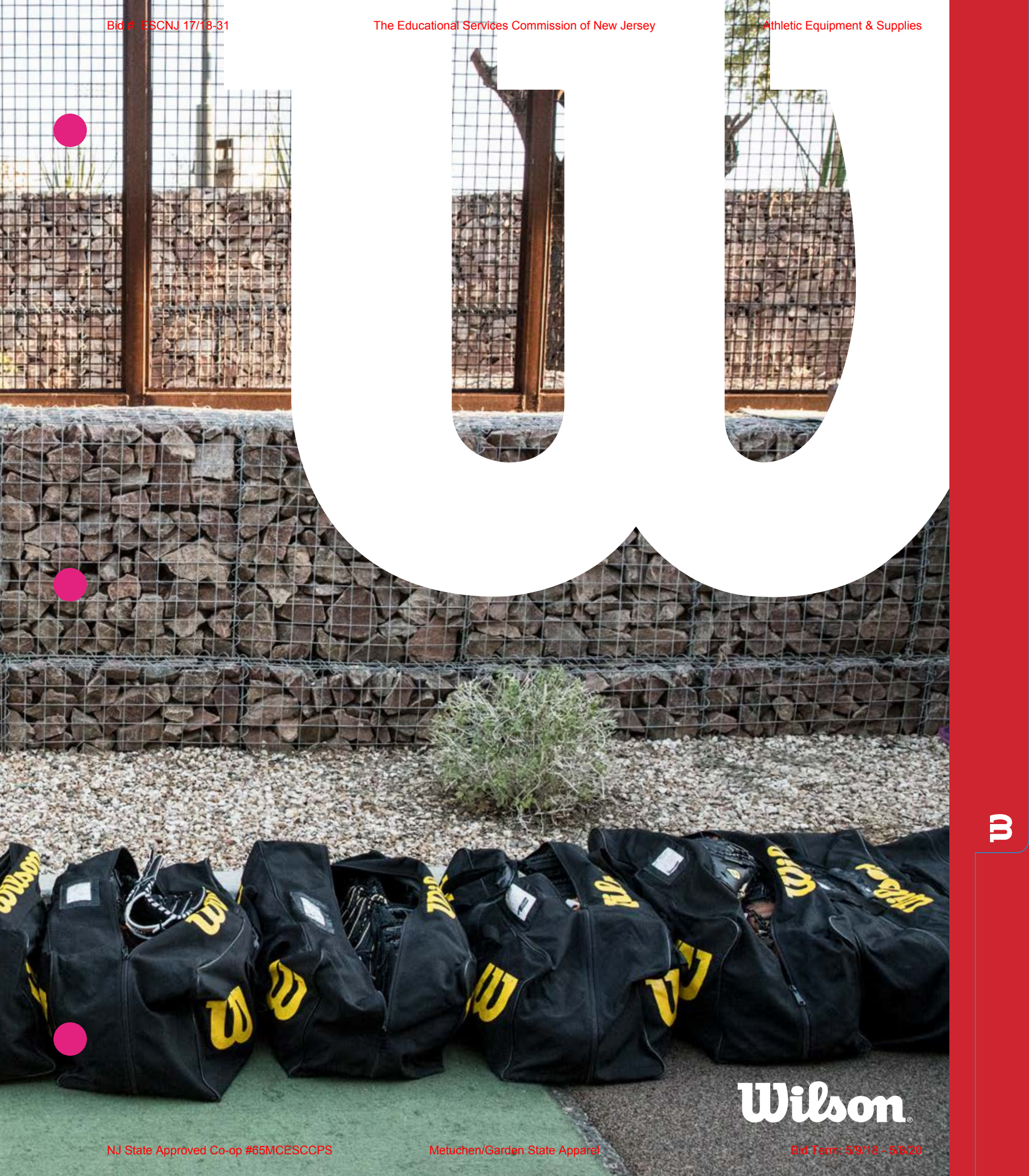

**Wilson**<sup>®</sup>



**DUSTIN PEDROIA**

**Boston Red Sox, 2B**

2018 A2000 DP15 GM



TM



# BALL GLOVES



THE OFFICIAL BASEBALL GLOVE  
OF MAJOR LEAGUE BASEBALL

# MLB<sup>®</sup>

## ADVISORY STAFF



**DANSBY SWANSON**  
Atlanta Braves, SS  
CUSTOM A2000 1787

### AL EAST

#### BALTIMORE ORIOLES

Anthony Santander [OF] A2K 1799/A2000 1799  
Chris Tillman [P] A2000 GG47 w/B2 Web  
Darren O'Day [P] A2K B212  
Michael Bourn [OF] A2000 KP92  
Mike Wright [P] A2K D33  
Mychal Givens [P] A2K D33  
Oliver Drake [P] A2000 B212  
Ryan Flaherty [INF] A2000 1781/A2000 G5/A2000 1617  
Wellington Castillo [C] A2000 33/A2000 1790 SS  
Zach Britton [P] A2000 B212/A2000 GG47



#### BOSTON RED SOX

Allen Craig [INF] A2000 2800/A2K 1799  
Andrew Benintendi [OF] A2000 KP92/A2000 1796  
Blake Swihart [C/OF] A2K M1  
Chris Young [OF] A2K 1799/A2K 1788  
Dustin Pedroia [INF] A2000 DP15 GM\*\*\*  
Eduardo Rodriguez [P] A2000 CK22  
Hanley Ramirez [INF] A2000 1787/A2000 2800 SS  
Marco Hernandez [INF] A2000 1787  
Mookie Betts [OF] A2K MB50 GM\*\*\*  
Rick Porcello [P] A2000 B2  
Tyler Thornburg [P] A2000 CK22  
Bryce Brentz [OF] A2000 1799/A2K AJ75  
Deven Marrero [INF] A2000 1787/A2K DW5  
Josh Rutledge [INF/OF] A2K DW5  
Matt Barnes [P] A2000 B2 SS/A2000 DW5 SS  
Steven Wright [P] A2000 B212/A2K B212  
Joe Kelly [P] A2K B212



#### NEW YORK YANKEES

Adam Warren [P] A2K ASO  
Chase Headley [INF] A2000 1781/A2000 1617  
Clint Frazier [OF] A2K KP92  
Dellin Betances [P] A2000 GG47  
Justus Sheffield [P] A2000 1788A/A2K 33  
Robert Refsnyder [OF] A2K 1799/A2K 1788 SS  
Ronald Torreyes [INF/OF] A2000 DW5 SS/A2000 1786  
Starlin Castro [INF] A2000 1786 SS  
Tyler Wade [INF] A2000 1787/A2000 1786



#### TAMPA BAY RAYS

Brad Boxberger [P] A2K B212  
Cory Rasmus [P] A2000 B2 SS  
Evan Longoria [INF] A2000 EL3  
Jake Odorizzi [P] A2000 CK22/A2K B212  
Jose De Leon [P] A2000 B2 SS/A2000 HG12  
Justin Marks [P] A2000 B2/A2K 33  
Luke Maile [C] A2K M1  
Matt Duffy [INF] A2000 1781  
Nathan Eovaldi [P] A2000 B212  
Shawn Tolleson [P] A2000 GG47  
Steve Souza [OF] A2000 KP92/A2K 1799  
Alex Cobb [P] A2K D33  
Nick Franklin [INF] A2000 EL3/A2000 OT6  
Wilson Ramos [C] A2000 1790



#### TORONTO BLUE JAYS

Aaron Loup [P] A2000 D33/A2000 B2  
Darwin Barney [INF] A2000 1786/A2000 1799 SS  
Lourdes Gurriel [INF/OF] A2K 1786/A2000 1786 SS  
Mike Bolsinger [P] A2000 CK22  
Richard Urena [INF] A2K 1786/A2000 /1786 SS  
Steve Pearce [INF] A2K 1799/A2K 2800



### AL CENTRAL

#### CHICAGO WHITE SOX

Adam Engel [OF] A2000 OT6/A2000 1799 SS  
Avisail Garcia [OF] A2000 1799 SS  
Carson Fulmer [P] A2K D33  
David Robertson [P] A2K B212  
Jose Abreu [INF] A2000 JA79  
Leury Garcia [INF] A2K TF21/A2K 1799  
Matt Purke [P] A2000 GG47  
Melky Cabrera [OF] A2000 1799  
Nate Jones [P] A2000 BW38  
Todd Frazier [INF] A2000 TDFTHR GM  
Yoan Moncada [INF] A2000 1787/A2K DW5/A2K KP92  
Zach Putnam [P] A2000 GG47  
Tim Anderson [INF] A2000 G4

#### CLEVELAND INDIANS

Andrew Miller [P] A2000 CK22/A2K D33  
Carlos Carrasco [P] A2000 XL/A2K ASO  
Dan Otero [P] A2K B212/A2K ASO  
Mike Clevinger [P] A2K ASO/A2K B212  
Carlos Santana [INF] A2000 1613/A2000 1786  
Jose Ramirez [INF] A2000 DW5/A2000 1786

#### DETROIT TIGERS

Alex Wilson [P] A2000 DW5  
Christin Stewart [OF] A2000 1799  
Daniel Norris [P] A2K DW5/A2000 CK22  
J.D. Martinez [OF] A2000 1799  
Justin Wilson [P] A2000 HG12/A2000 GG47  
Matt Boyd [P] A2000 GG47 w/B2 Web  
Miguel Cabrera [INF] A2000 MC24  
Omar Infante [INF] A2K 1786/A2K DW5  
Dixon Machado [INF] A2000 1786/A2K 1786

#### KANSAS CITY ROYALS

Alberto Albuquerque [P] A2000 B2/A2K B2  
Bobby Parnell [P] A2000 B2/A2K D33  
Brandon Moss [INF] A2000 2800  
Chris Withrow [P] A2K B212  
Christian Colon [INF] A2000 1786  
Ian Kennedy [P] A2000 1915  
Jorge Bonifacio [OF] A2000 ELO/A2000 1799  
Jorge Soler [OF] A2000 1799 SS  
Luke Hochevar [P] A2000 OT6  
Matt Strahm [P] A2000 GG47/A2000 D33  
Nathan Karns [P] A2000 B212  
Hunter Dozier [INF] A2K KP92/A2K 2800  
Lorenzo Cain [OF] A2000 1799  
Miguel Almonte [P] A2K DW5/A2K B212

#### MINNESOTA TWINS

Alex Wimmers [P] A2K CJW/A2K B2  
Brian Dozier [INF] A2000 G4  
Eddie Rosario [INF/OF] A2K 1799/A2000 DP15  
Ehire Adrianza [INF] A2000 1786/A2000 EL3  
J.R. Murphy [C] A2000 1790 SS  
JT Chargois [P] A2000 CK22/A2000 B2  
Nick Gordon [INF] A2K 1786/A2000 1786  
Randy Rosario [P] A2000 B2/A2K D33  
Travis Blankenhorn [INF] A2K DATDUDE GM/A2K DP15 GM  
J.O. Berrios [P] A2K B212  
Jason Castro [C] A2000 1790  
Kennys Vargas [INF] A2000 1617/A2000 1617 SS

### AL WEST

#### HOUSTON ASTROS

Brad Peacock [P] A2K B212/A2000 B2  
Carlos Beltran [OF] A2K 1799  
Carlos Correa [INF] A2000 1785  
Chris Devenski [P] A2K D33/A2K B212  
Colin Moran [INF] A2000 EL3/A2000 1613  
Collin McHugh [P] A2000 XL  
Evan Gattis [INF] A2000 1617  
Josh Reddick [OF] A2000 1799  
Marwin Gonzalez [INF] A2000 1716  
Mike Fiers [P] A2000 B2  
Norichika Aoki [OF] A2000 1786/A2000 1613  
Preston Tucker [OF] A2000 1799/A2000 1799 SS  
Tony Kemp [INF/OF] A2000 1799/A2000 DP15  
Tyler White [INF] A2000 1787 SS/A2K 2800  
Yulieski Gurriel [INF] A2K DW5/A2K 2800  
Jose Altuve [INF] A2000 JA27 GM  
Lance McCullers [P] A2K HG12/A2K D33  
Teoscar Hernandez [OF] A2K 1799/A2000 1799 SS



#### LOS ANGELES ANGELS

Andrew Bailey [P] A2000 B212/A2000 B2  
CJ Cron [INF] A2000 2800/A2K 2800  
Danny Espinosa [INF] A2000 1786/A2000 1786  
Jeffrey Marte [INF] A2000 1617/A2000 DW5



#### OAKLAND ATHLETICS

Adam Rosales [INF] A2000 DP15/A2000 KP92  
Daniel Mengden [P] A2K B212/A2K KP92  
Joe Wendle [INF] A2K 1787/A2000 DW5 SS  
Matt Joyce [OF] A2000 KP92  
Rajai Davis [OF] A2000 JH32/A2000 YP66  
Raul Alcantara [P] A2000 ASO  
Santiago Casilla [P] A2000 CJW



#### SEATTLE MARINERS

Ariel Miranda [P] A2000 1796/A2K D33  
Carlos Ruiz [C] A2000 1791 PUD  
Christian Bergman [P] A2000 L/A2K D33  
Dan Altavilla [P] A2000 B2/A2000 XL  
James Ramsey [OF] A2K 1799  
Nelson Cruz [OF] A2000 1799  
Rob Whalen [P] A2000 HG12/A2K B2  
Robinson Cano [INF] A2000 RC22 GM  
Shawn O'Malley [INF] A2K DP15 GM/A2000 EI3/A2000 1617 SS  
Tuffy Gosewisch [C] A2000 33  
Tyler O'Neill [OF] A2000 OT6/A2K KP92  
Yovani Gallardo [P] A2000 D33



#### TEXAS RANGERS

Andrew Cashner [P] A2000 B212  
Anthony Bass [P] A2000 B2/A2000 B2 SS  
Brett Nicholas [C] A2K M1  
Dillon Gee [P] A2K D33  
Drew Robinson [OF] A2K 2800/A2K 1799/A2000 1787  
Elvis Andrus [INF] A2000 1788/A2000 X2  
Hanser Alberto [INF] A2K DW5/A2000 1786  
Josh Hamilton [OF] A2000 1883/A2000 JH32  
Jurickson Profar [INF/OF] A2K 1788/A2K 1799  
Michael De Leon [S] A2000 DP15 SS  
Rougned Odor [INF] A2000 1786  
Mike Napoli [INF] A2000 1613  
Nick Martinez [P] A2000 ASO





**YOENIS CESPEDES**  
New York Mets, OF  
Custom A2000 SP135



**MOOKIE BETTS**  
Boston Red Sox, OF  
A2K MB50 GM

**ANDREW BENINTENDI**  
Boston Red Sox, OF  
Custom A2000 KP92



## NL EAST



### ATLANTA BRAVES

Brandon Phillips [INF] A2K DATDUDE GM  
Dansby Swanson [INF] A2000 1787  
Ender Inciarte [OF] A2000 1799  
Luke Jackson [P] A2K B212/A2K 33  
Micah Johnson [INF] A2K 1786/A2K OT6  
Mike Foltynewicz [P] A2000 HG12/A2000 ASO  
Ozzie Albies [INF] A2000 1787 SS  
Paco Rodriguez [P] A2000 B2/A2K B212  
Travis Demeritte [INF] A2K 1786/A2000 1786



### MIAMI MARLINS

AJ Ellis [C] A2000 1790\*  
Austin Nola [C] A2000 1791 PUD/A2000 1791 SS  
Jeff Locke [P] A2000 B212/A2000 CK22  
Martin Prado [INF] A2000 EL3  
Matt Den Dekker [OF] A2K 1799/A2000 KP92  
Miguel Rojas [INF] A2000 1786/A2000 2800  
AJ Ramos [P] A2000 B2 SS  
Dee Gordon [INF] A2000 1786



### NEW YORK METS

David Wright [INF] A2K DW5  
Josh Smoker [P] A2K B212  
Juan Lagares [OF] A2000 1799  
Kevin Plawecki [C] A2000 M1  
Lucas Duda [INF] A2000 1617  
Matt Reynolds [INF] A2K 1787/A2000 1787  
Michael Conforto [OF] A2000 ELO/A2K 1799  
Yoenis Cespedes [OF] A2000 1799/A2000 SP135  
Dominic Smith [INF] A2K 2802



### PHILADELPHIA PHILLIES

Aaron Nola [P] A2000 CK22  
Andres Blanco [INF] A2000 JA27 GM/A2000 1786 SS  
Cesar Hernandez [OF] A2000 1788  
Clay Buchholz [P] A2000 XL  
Jeanmar Gomez [P] A2K B212  
Jerad Eickhoff [P] A2K B212/A2000 B212 SS  
Joaquin Benoit [P] A2K B212  
Maikel Franco [INF] A2K 1787/A2K TF21/A2K 1786  
Mickey Moniak [OF] A2K 1799  
Cameron Rupp [C] A2000 M1 SS  
Roman Quinn [OF] A2K 1799/A2K KP92



### WASHINGTON NATIONALS

Adam Lind [OF] A2000 2800  
Brian Goodwin [OF] A2K 1799  
Daniel Murphy [INF] A2K 1787/A2K 2800  
Derek Norris [C] A2000 M1 SS/A2000 1791  
Gio Gonzalez [P] A2000 GG47  
Koda Glover [P] A2000 B2  
Sammy Solis [P] A2000 B212  
Spencer Kieboom [C] A2000 1791  
Tanner Roark [P] A2000 HG12



## NL CENTRAL

### CHICAGO CUBS

Alec Mills [P] A2000 CK22/A2K B2  
Eloy Jimenez [OF] A2K KP92/A2000 1799  
Michael Montgomery [P] A2K B212/A2K D33  
Miguel Montero [C] A2000 1791 PUD/A2000 1799 SS  
Tommy La Stella [INF] A2000 1786  
Willson Contreras [C] A2K M1/A2000 1790 SS  
Rob Zastryzny [P] A2K D33



### CINCINNATI REDS

Arisemendy Alcantara [INF] A2000 DP15/A2000 06  
Aristides Aquino [OF] A2000 1799 SS/A2K 1799  
Homer Bailey [P] A2000 1915  
Jackson Stephens [P] A2K D33  
Jesse Winker [OF/INF] A2000 1799 SS/A2K 2802  
Jose Peraza [INF] A2000 1786/A2000 1617  
Keury Mella [P] A2000 1796/A2000 B2  
Lisalverto Bonilla [P] A2000 OT6/A2K B2  
Phillip Ervin [OF] A2000 KP92/A2000 JH32  
Zack Cozart [INF] A2000 1786/A2K 1786



### MILWAUKEE BREWERS

Brett Phillips [OF] A2000 1799 SS  
Corey Knebel [P] A2K B212/A2000 CK22  
Domingo Santana [OF] A2000 1799/A2000 1799 SS  
Eric Sogard [INF] A2000 KP92  
Jesus Aguilar [INF] A2K 2800/A2000 1613  
Jonathan Villar [INF] A2000 1786  
Keon Broxton [OF] A2K 1799  
Kirk Nieuwenhuis [OF] A2000 1799  
Ryan Braun [OF] A2K 1799  
Taylor Jungmann [P] A2000 B2  
Wily Peralta [P] A2000 B12



### PITTSBURGH PIRATES

Chris Bostick [INF] A2K 1786/A2000 1786  
Drew Hutchison [P] A2000 B212  
Jameson Taillon [P] A2K D33  
Joey Terdoslavich [INF] A2000 1799 SS/A2K 2800  
John Jaso [OF/INF] A2K DW5/A2000 1617  
Jose Osuna [INF/OF] A2000 1613/A2000 EI3  
Josh Bell [INF] A2000 MC24  
Josh Harrison [INF] A2K 1786  
Max Moroff [INF] A2K G4/A2K 1786  
Trevor Williams [P] A2K D33



### ST. LOUIS CARDINALS

Jacob Wilson [INF] A2K 1787  
Jedd Gyorko [INF] A2000 DW5/A2000 DP15  
Jhonny Peralta [INF] A2K 1781/A2K 1787  
John Gant [P] A2000 HG12/A2K D33  
Kevin Siegrist [P] A2K B212  
Lance Lynn [P] A2000 KP92 w/ B2 Web  
Mike Leake [P] A2000 1788A



## NL WEST

### ARIZONA DIAMONDBACKS

Brandon Drury [INF] A2000 1786  
David Peralta [OF] A2000 DP6  
Jeremy Hazelbaker [OF] A2K 1799  
Ketel Marte [INF] A2000 DP15  
Nick Ahmed [INF] A2000 1788  
Pat Corbin [P] A2000 B212



### COLORADO ROCKIES

Adam Ottavino [P] A2000 DW5/A2000 XL  
Alexi Amarista [INF] A2000 1786  
Antonio Senzateza [P] A2K D33/A2K B2  
Brendan Rodgers [INF] A2K 1788  
Chris Rusin [P] A2K B2  
Cristhian Adames [INF] A2K DW5/A2000 2800  
Dustin Garneau [C] A2000 1790  
Gerardo Parra [OF] A2000 KP92  
Greg Holland [P] A2000 CK22  
Jason Motte [P] A2000 L/A2000 X2  
Raimel Tapia [OF] A2000 1799  
Tom Murphy [C] A2000 1790



### LOS ANGELES DODGERS

Alex Wood [P] A2K B212/A2000 B2 SS  
Andrew Toles [OF] A2000 ELO/A2000 1799 SS  
Austin Barnes [C] A2000 1790  
Chris Hatcher [P] A2K CJW  
Clayton Kershaw [P] A2000 CK22 GM  
Logan Forsythe [INF] A2000 DP15  
Luis Avilan [P] A2K D33/A2000 B2  
Rich Hill [P] A2000 B2  
Robert Segedin [INF] A2K DW5/A2000 1617  
Yasiel Puig [OF] A2000 YP66  
Grant Dayton [P] A2K B212  
Justin Turner [INF] A2000 DW5 SS/A2000 1787  
Ross Stripling [P] A2K B2/A2000 B2



### SAN DIEGO PADRES

Buddy Baumann [P] A2000 G4/A2000 1796  
Carlos Asuaje [INF] A2000 1788/A2000 1786  
Kevin Quackenbush [P] A2000 ASO/A2000 OT6  
Luis Sardinas [INF] A2K DW5  
Travis Jankowski [OF] A2000 1799/A2K 1799  
Tyrell Jenkins [P] A2000 CK22/A2000 L  
Clayton Richard [P] A2000 1796



### SAN FRANCISCO GIANTS\*\*

Albert Suarez [P] A2000 B2/A2K B2  
Brandon Belt [INF] A2K 2802  
George Kontos [P] A2K B212  
Gorkys Hernandez [OF] A2000 1799 SS/A2K 1275  
Mark Melancon [P] A2K CJW  
Michael Morse [INF] A2000 OT6/A2K 2800  
Ray Black [P] A2K 33/A2000 1791 PUD  
Shawon Dunston Jr. [OF] A2K 1799  
Ty Blach [P] A2K ASO/A2000 OT6  
Tyler Beede [P] A2000 B2  
Dan Slania [P] A2000 B2/A2000 33



\* Pro Stock™ Catcher's Gear  
\*\* 2016 MLB Wilson® Defensive Team of the Year Winner  
\*\*\* 2016 Wilson® Defensive Player of the Year

40 Man Roster as of 3-25-2017  
NOTE: Pros may choose to customize equipment and make changes to models shown.



THE OFFICIAL BASEBALL GLOVE OF MAJOR LEAGUE BASEBALL



# PRO STOCK® GLOVES

Pro Stock® Patterns used by the pros. The best ball glove leather out there. Glove technicians devoted to hand crafting the hardest working gloves in the game. It's no surprise that Major League Baseball® players choose to use Wilson® to get them through a 162 game season. The same patterns, leather, and craftsmanship go into every Wilson Pro Stock glove whether it's made for play on an MLB field or your local diamond. Choose YOUR glove.

SIZE	PATTERN	A2K®	A2000®	A2000® SUPER SKIN™	A2000® PEDROIA FIT
<b>INFIELD</b>					
11.25"	1788A				
11.25"	1788				
11.25"	PF88				
11.5"	DATDUDEGM				
11.5"	DP15				
11.5"	1786				
11.5"	1789				
11.5"	RC22GM				
11.5"	PP05				
11.5"	JA27GM				
11.75"	DP15GM (2018)				
11.75"	1787				
11.75"	1785				
12"	1721				
12.5"	TDFTHRGM				
<b>1ST BASE</b>					
12"	2800				
12.5"	1617				







NEW NEW FOR 2018  
 GM GAME MODEL  
 SS SUPER SKIN  
 PF PEDROIA FIT

SIZE	PATTERN	A2K®	A2000®	A2000® SUPER SKIN™	A2000® PEDROIA FIT
<b>OUTFIELD</b>					
12.25"	PF92				<span>NEW</span> <span>PF</span>
12.5"	KP92				
12.75"	1799	<span>NEW</span>	<span>NEW</span>	<span>SS</span>	
12.75"	OT6		<span>NEW</span>	<span>NEW</span> <span>SS</span>	
12.75"	1775	<span>NEW</span>			
12.75"	MB50GM	<span>NEW</span> <span>GM</span> <span>SS</span>			
<b>PITCHER</b>					
11.75"	CK22		<span>GM</span>		
11.75"	D33	<span>NEW</span>	<span>NEW</span>		
12"	B2	<span>NEW</span>		<span>NEW</span> <span>SS</span>	
<b>CATCHER</b>					
32.5"	791/PUDGE				
33"	CM33				
33.5"	M1	<span>NEW</span>		<span>SS</span>	
33.5"	M2			<span>NEW</span> <span>SS</span>	
34"	1790			<span>SS</span>	



**TODD FRAZIER**  
Chicago White Sox™, 3B  
A2000 TOFTHR GM

**SHIGEAKI ASO**  
Wilson Glove Master Craftsman



# GAME MODEL GLOVES

## LEATHER WITH MAJOR PRESENCE

They're not just worn by professionals. They're designed by them. Each year, Wilson Ball Glove Master Craftsman Shigeaki Aso works with select members of our MLB Advisory Staff players to build a game model glove to their particular specs and style.

Aso-san puts his passion for perfection into the gloves, meeting with players to collaborate and receive their feedback so their new glove is built to work for the player's game. Each glove is unique, culminating in the most innovative line of Wilson Game Model gloves yet.

### A2K® GAME MODEL GLOVES



**NEW**  
**GM**

#### BRANDON PHILLIPS

New team, same flashy custom. Brandon's 2018 gamer has made a splash in Atlanta – and why not? The new design pops. We'd expect nothing less.

**INFIELD** 11.5"

STOCK NO.  
WTA2KRB18DTPDUDE  
MSRP  
\$359.95

#### BRANDON'S GLOVE FEATURES

- H-Web
- Game Model of Brandon Phillips
- Navy, Red and Yellow Gold



**NEW**  
**GM**

#### MOOKIE BETTS

Mookie's debut in the game model line is a flashy A2K®, made in 12.75" for the additional length he wants in the outfield. If there's a ball within reach, Mookie and this glove will snag it.

**OUTFIELD** 12.75"

STOCK NO.  
WTA2KRB18MB50GM  
WTA2KLB18MB50GM [LHT]  
MSRP  
\$359.95

#### MOOKIE'S GLOVE FEATURES

- Dual Post Web
- Red and White with Black SuperSkin™
- Game Model of Mookie Betts



# A2000® GAME MODEL GLOVES



NEW  
GM

## JOSE ALTUVE

Jose Altuve's game keeps getting better, and so does his gamer. The new JA27 features a new design for a more shallow pocket and easier access, and is built with a pro-laced T-Web to help with a faster transfer. Just like Jose's game, it's not to be missed.

INFIELD 11.5"

STOCK NO.  
WTA20RB18JA27GM  
MSRP  
\$259.95

### JOSE'S GLOVE FEATURES

- Chevron Cross Web
- Navy and Orange
- Game Model of Jose Altuve
- New pattern featuring Gap Welting



NEW  
GM  
SS

## ROBINSON CANO

Robbie's a SuperSkin guy. Has been for years. He loves that the material is half the weight of regular leather, and twice as strong. It'll stay light even if the fields get wet. You'll love it, too.

INFIELD 11.5"

STOCK NO.  
WTA20RB18RC22GM  
MSRP  
\$259.95

### ROBINSON'S GLOVE FEATURES

- H-Web
- Mariner Green with Black SuperSkin™
- Game Model of Robinson Cano

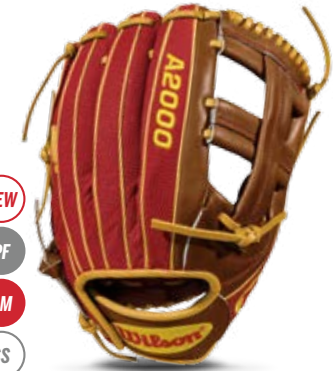

NEW  
PF  
GM  
SS

## DUSTIN PEDROIA

Dustin is keeping things fresh – and light – this year. For the first time ever, his gamer features a Cross Web so he can get an even quicker transfer at second base and SuperSkin™ for additional lightness and speed. Same trusted model, new look.

INFIELD 11.75"

STOCK NO.  
WTA20RB18DP15GM  
MSRP  
\$259.95

### DUSTIN'S GLOVE FEATURES

- Cross Web
- Pedroia Fit™
- Saddle Tan and Yellow with Red SuperSkin™
- Game Model of Dustin Pedroia



NEW  
GM

## TODD FRAZIER

Todd Frazier designed his first game model glove for the game of inches that is the hot corner. It's 12.25" to give him the range he's looking for and every advantage he needs for balls ripped his way..

INFIELD 12.25"

STOCK NO.  
WTA20RB18TDFTHR  
MSRP  
\$259.95

### TODD'S GLOVE FEATURES

- Dual Post Web
- Grey, Black and White
- Game Model of Todd Frazier



GM

## CLAYTON KERSHAW

Clayton Kershaw finds a groove and sticks with it. He's worn our classic B2 since his first days in Dodger camp. True to his roots, he hasn't changed a thing since.

PITCHER 11.75"

STOCK NO.  
WTA20RB15CK22GM  
WTA20LB15CK22GM [LHT]  
MSRP  
\$259.95

### CLAYTON'S GLOVE FEATURES

- 2-Piece Web
- Game Model for Clayton Kershaw
- Black



# A2K<sup>®</sup>

## THE PREMIER GLOVE

The finest cuts of leather. Meticulous construction. Three times more hand shaping by Wilson<sup>®</sup> master technicians. All these qualities make the A2K<sup>®</sup> our premier glove. The one players turn to when they want a long-lasting glove that breaks in without breaking down. Made from the top 5% of Pro Stock<sup>®</sup> Select leather, each hide is chosen for consistency and flawlessness, so the A2K<sup>®</sup> baseball glove is the most premium glove available.

### 1. PRO STOCK<sup>®</sup> SELECT LEATHER:

The top 5% of Pro Stock hides are chosen by a triple sorting process for consistency and flawlessness. The 2018 A2Ks are Copper, Blonde and Black.

### 2. ROLLED DUAL WELTING<sup>™</sup>:

Thin strips of Pro Stock leather are skived thin and rolled to provide long-lasting shape and a quicker break-in.

### 3. DOUBLE PALM CONSTRUCTION:

A thin, strategically cut piece of leather is placed between the palm liner and outer shell, providing maximum pocket stability.

### 4. 3X MORE SHAPING:

A master technician spends three times longer pounding and shaping the A2K<sup>®</sup> by hand, which reduces break-in time.





NEW  
GM



INFIELD 11.5"  
STOCK NO.  
WTA2KRB18DTDUDE  
MSRP  
\$359.95  
• H-Web  
• Game Model of Brandon Phillips  
• Navy, Red and Yellow Gold

NEW



INFIELD 11.5"  
STOCK NO.  
WTA2KRB181786  
MSRP  
\$359.95  
• H-Web  
• Copper and Blonde

NEW



INFIELD 11.75"  
STOCK NO.  
WTA2KRB181787  
MSRP  
\$359.95  
• H-Web  
• Copper and Blonde

NEW



INFIELD 12"  
STOCK NO.  
WTA2KRB181721  
MSRP  
\$359.95  
• Dual Post Web  
• Copper, Black and White

NEW



PITCHER 11.75"  
STOCK NO.  
WTA2KRB18D33  
WTA2KLB18D33 [LHT]  
MSRP  
\$359.95  
• Closed Pro Laced Web  
• Copper and Black

NEW



PITCHER 12"  
STOCK NO.  
WTA2KRB18B2  
WTA2KLB18B2 [LHT]  
MSRP  
\$359.95  
• 2-Piece Web  
• Copper

NEW



OUTFIELD 12.75"  
STOCK NO.  
WTA2KRB181775  
WTA2KLB181775 [LHT]  
MSRP  
\$359.95  
• Wide Single Post Web  
• Copper and Blonde  
• New Pattern

NEW



OUTFIELD 12.75"  
STOCK NO.  
WTA2KRB181799  
WTA2KLB181799 [LHT]  
MSRP  
\$359.95  
• Dual Post Web  
• Copper, Blonde and White

NEW  
GM



OUTFIELD 12.75"  
STOCK NO.  
WTA2KRB18MB50GM  
WTA2KLB18MB50GM [LHT]  
MSRP  
\$359.95  
• Dual Post Web  
• Red, Black and White with Black SuperSkin™  
• Game Model of Mookie Betts  
• 1799 base pattern

NEW



CATCHER 33.5"  
STOCK NO.  
WTA2KRB18M1  
MSRP  
\$359.95  
• Half Moon Web  
• Copper and Black

NEW



1ST BASE 12.5"  
STOCK NO.  
WTA2KRB181617  
WTA2KLB181617 [LHT]  
MSRP  
\$359.95  
• Double Horizontal Bar Web  
• Copper, Blonde and Black



# A2000®

## PERENNIAL EXCELLENCE THROUGH INNOVATION

Constantly improving patterns. Materials that perform. Dependable construction. The evolution of the A2000 baseball glove has been driven by insights from the Wilson Advisory Staff. This is why hard working players love its unmatched feel, rugged durability and perfect break-in.

### 1. PRO STOCK® SELECT LEATHER:

- Made specifically for Wilson ball gloves, this American Steerhide is preferred by professional players for its rugged durability and an unmatched feel.

### 2. DUAL WELTING™:

- Two strips of leather placed along each finger back create a durable pocket and a long lasting break-in.

### 3. PRO STOCK PATTERNS:

- Exclusive hand designed patterns continuously improved by Aso-san and the Wilson Advisory Staff.

### 4. DRI-LEX™:

- Ultra-breathable wrist lining transfers moisture from the skin, keeping the hand cool and dry.

### 5. GAP WELTING:

- On select patterns.





**INFIELD** 11.25"  
STOCK NO.  
WTA20RB171788  
MSRP  
\$259.95

- H-Web
- 2X Lacing at Base of the Web
- Black with White



**INFIELD** 11.25"  
STOCK NO.  
WTA20RB171788A  
MSRP  
\$259.95

- A-Web
- Grey and Royal Blue

NEW



**INFIELD** 11.5"  
STOCK NO.  
WTA20RB181786  
MSRP  
\$259.95

- H-Web
- Black and Blonde
- 2X Lacing at Base of the Web



**INFIELD** 11.5"  
STOCK NO.  
WTA20RB171786  
MSRP  
\$259.95

- H-Web
- 2X Lacing at Base of the Web
- Saddle Tan Pro Stock Leather with Blonde and White Accents

NEW



**INFIELD/PITCHER** 11.5"  
STOCK NO.  
WTA20RB181789  
WTA20LB181789 [LHT]  
MSRP  
\$259.95

- Pro Laced T-Web
- Orange Tan and Royal

NEW



**INFIELD** 11.5"  
STOCK NO.  
WTA20RB18PP05  
MSRP  
\$259.95

- Dual Post Web
- Brick Red with Vegas Gold accents

NEW

GM



**INFIELD** 11.5"  
STOCK NO.  
WTA20RB18JA27GM  
MSRP  
\$259.95

- Chevron Cross Web
- Navy and Orange
- Game Model of Jose Altuve
- New pattern featuring Gap Welting

NEW



**INFIELD** 11.75"  
STOCK NO.  
WTA20RB181787  
MSRP  
\$259.95

- H-Web
- Dark Brown and Blonde
- 2X Lacing at Base of the Web

NEW



**INFIELD** 11.75"  
STOCK NO.  
WTA20RB181785  
MSRP  
\$259.95

- Cross Web with Baseball Stitch
- Black with Blonde and Red
- New pattern featuring Gap Welting

NEW

GM



**INFIELD** 12.25"  
STOCK NO.  
WTA20RB18TDFTHR  
MSRP  
\$259.95

- Dual Post Web
- Grey with Black and White
- Game Model of Todd Frazier

GM



**PITCHER** 11.75"  
STOCK NO.  
WTA20RB15CK22GM  
WTA20LB15CK22GM [LHT]  
MSRP  
\$259.95

- 2-Piece Web
- Game Model of Clayton Kershaw

NEW



**PITCHER** 11.75"  
STOCK NO.  
WTA20RB18D33  
WTA20LB18D33 [LHT]  
MSRP  
\$259.95

- Closed Pro Laced Web
- Gap Welting for a flat and more consistent pocket
- Blonde and Black





**OUTFIELD** 12.5"  
 STOCK NO.  
 WTA20RB17KP92  
 WTA20LB17KP92 [LHT]  
 MSRP  
 \$259.95  
 • Pro Laced T-Web  
 • Grey and Black

NEW



**OUTFIELD** 12.75"  
 STOCK NO.  
 WTA20RB180T6  
 WTA20LB180T6 [LHT]  
 MSRP  
 \$259.95  
 • 6 Finger Trap Web  
 • Blonde, Black and Red

NEW



**OUTFIELD** 12.75"  
 STOCK NO.  
 WTA20RB181799  
 WTA20LB181799 [LHT]  
 MSRP  
 \$259.95  
 • Dual Post Web  
 • Orange Tan and Black



# A2000<sup>®</sup> SUPERSKIN<sup>™</sup>

## STRONG, DURABLE AND LIGHT

The A2000<sup>®</sup> SuperSkin<sup>™</sup> glove series is the utility player of the Wilson<sup>®</sup> lineup. A versatile mix of Pro Stock<sup>®</sup> Leather and man-made SuperSkin makes the glove stronger, lighter and easier to break in than the all-leather A2000.

1. SUPERSKIN<sup>™</sup>:  
 2x stronger than cowhide leather and only 1/2 the weight.
2. STRATEGIC DESIGN:  
 Leather where you need and SuperSkin where you don't. SuperSkin is placed on the back of the glove where it takes the most beating.
3. PRO STOCK<sup>®</sup> LEATHER:  
 Made specifically for Wilson ball gloves, this American Steerhide is preferred by professional players for its rugged durability and unmatched feel.



**INFIELD** 11.25"  
 STOCK NO.  
 WTA20RB171788SS  
 MSRP  
 \$259.95  
 • H-Web  
 • Grey Pro Stock<sup>®</sup> with Black SuperSkin<sup>™</sup> and Red Logos and Palm Welting

NEW

SS



**INFIELD** 11.5"  
 STOCK NO.  
 WTA20RB181786SS  
 MSRP  
 \$259.95  
 • H-Web  
 • Silver and Brick Red with Black SuperSkin<sup>™</sup>

NEW

GM

SS



**INFIELD** 11.5"  
 STOCK NO.  
 WTA20RB18RC22GM  
 MSRP  
 \$259.95  
 • H-Web  
 • Mariner Green with Black SuperSkin<sup>™</sup>  
 • Game Model of Robinson Cano

SS



**INFIELD** 11.75"  
 STOCK NO.  
 WTA20RB171787SS  
 LIST PRICE  
 \$259.95  
 • H-Web  
 • White with Black SuperSkin<sup>™</sup>

NEW

SS



PITCHER 12"

STOCK NO.  
WTA20RB18B212SS  
WTA20LB18B212SS [LHT]  
MSRP  
\$259.95

- 2-Piece Web
- Dark Brown with Black SuperSkin™

SS



OUTFIELD 12.75"

STOCK NO.  
WTA20RB171799SS  
WTA20LB171799SS [LHT]  
MSRP  
\$259.95

- Dual Post Web
- Black with Black SuperSkin™ and Red Stitching

NEW

SS



OUTFIELD 12.75"

STOCK NO.  
WTA20RB180T6SS  
WTA20LB180T6SS [LHT]  
MSRP  
\$259.95

- 6-Finger Trap Web
- Blond and Red with Black SuperSkin™

A2000® MITTS



1ST BASE 12"

STOCK NO.  
WTA20RB172800  
WTA20LB172800 [LHT]  
MSRP  
\$259.95

- Reinforced Single Post Web
- Double break design
- Most popular MLB® 1st Base Pattern

SS



1ST BASE 12.5"

STOCK NO.  
WTA20RB171617SS  
WTA20LB171617SS [LHT]  
MSRP  
\$259.95

- Double Horizontal Bars
- Charcoal Grey and Black SuperSkin™



CATCHER 32.5"

STOCK NO.  
WTA20RB17PUDGE  
MSRP  
\$259.95

- Half Moon Web
- MLB® Most Popular Catchers Mitt Pattern
- Orange Tan and Black



CATCHER 33"

STOCK NO.  
WTA20RB17CM33  
MSRP  
\$259.95

- Half Moon Web
- Blonde with Red Stitching and Welting

SS



CATCHER 33.5"

STOCK NO.  
WTA20RB17M1SS  
MSRP  
\$259.95

- Half Moon Web
- Black Pro Stock® Leather combined with SuperSkin™ and White Accents

NEW

SS



CATCHER 33.5"

STOCK NO.  
WTA20RB18M2SS  
MSRP  
\$259.95

- Half Moon Web
- Black and Grey
- Thumb Protector

SS



CATCHER 34"

STOCK NO.  
WTA20RB17190SS  
MSRP  
\$259.95

- Half Moon Web
- Black and Grey combined with SuperSkin™





# A2000<sup>®</sup> PEDROIA FIT™

## MORE A2000 PATTERNS WITH A SNUG FIT

Wilson's innovative Pedroia Fit™ was initially created for the DP15, giving Dustin Pedroia and other players with smaller hands a glove that fits their game. Smaller hand opening, narrower finger stalls and more—the same quality and craftsmanship behind the DP15 is now all over the field.

- PEDROIA FIT™:**  
Several internal changes make these A2000 patterns function perfectly on smaller hands.
- NARROW FINGER STALLS:**  
Made smaller and thinner to fit small hands. Thumb and pinky brought closer together to maximize hand strength.
- ROLLED DUAL WELTING™:**  
Provides a quicker break-in but doesn't break down.

NEW

PF



INFIELD 11.25"

STOCK NO.  
WTA20RB18PF88  
MSRP  
\$259.95

- H-Web
- Black, Blonde and Red
- Pedroia Fit™

PF



INFIELD 11.5"

STOCK NO.  
WTA20RB17DP15  
MSRP  
\$259.95

- H-Web
- Black with Grey Laces
- Pedroia Fit™

NEW

PF



INFIELD 11.5"

STOCK NO.  
WTA20RB18DP15  
MSRP  
\$259.95

- H-Web
- Orange Tan
- Pedroia Fit™

NEW

PF

SS



INFIELD 11.5"

STOCK NO.  
WTA20RB18DP15SS  
MSRP  
\$259.95

- H-Web
- Blonde and Tropical Blue with Black Super Skin™
- Pedroia Fit™

NEW

PF

GM

SS



INFIELD 11.75"

STOCK NO.  
WTA20RB18DP15GM  
MSRP  
\$259.95

- Cross Web
- Saddle Tan and Yellow with Red Super Skin™
- Game Model of Dustin Pedroia

NEW

PF



INFIELD 12.25"

STOCK NO.  
WTA20RB18PF92  
MSRP  
\$259.95

- Pro Laced T-Web
- Grey, Black and Yellow
- Pedroia Fit™



# A1000™

## SOFT, STURDY LEATHER THAT'S GAME-READY

The new A1000 line of gloves has the Pro Stock patterns you see in ballparks everywhere, in a soft, yet sturdy leather that's game-ready right away. The A1000 models are hand-designed patterns continuously improved by the Wilson Baseball team, optimized for faster break-in so you can make an immediate impact.

1. **TRUE PRO STOCK FEEL:**  
Our best A1000 ever captures the true feel of an A2000 but with game-ready materials.
2. **STURDY AND SOFT:**  
Strength where you need it, softness where you don't. The A1000 is soft to take your shape, without softening the structural necessities.
3. **FULL-GRAIN LEATHER:**  
All leather shell, rawhide laces, leather lining.



ALL POSITIONS 11.25"

STOCK NO.  
WTA10RB181788  
MSRP  
\$129.95

- H-Web
- Pedroia Fit™
- Black with Grey and Tropical Accents



ALL POSITIONS 11.5"

STOCK NO.  
WTA10RB181786  
MSRP  
\$129.95

- H-Web
- Grey and Red



ALL POSITIONS 11.5"

STOCK NO.  
WTA10RB181789  
WTA10LB181789 [LHT]  
MSRP  
\$129.95

- Pro Laced T-Web
- Black and Grey with Red Stitching



ALL POSITIONS 12.5"

STOCK NO.  
WTA10RB18KP92  
WTA10LB18KP92 [LHT]  
MSRP  
\$129.95

- Pro Laced T-Web
- Black with Grey and Red





# A900™

## BROKEN IN AND READY TO GO

The A900™ baseball glove has a cool, old-school look with its dark brown leather. Even better, grounders, line drives and fly balls don't stand a chance with a glove that's ready on Day One. There's no long winter break-in or sore knuckles punching the leather. The A900 will be ready when you are.

- 1. DOUBLE PALM CONSTRUCTION (FRONT SIDE):**  
A thin, strategically cut piece of leather is placed between the palm liner and outer shell, providing maximum pocket stability.
- 2. FULL LEATHER CONSTRUCTION:**  
Leather shell, laces and palm liner. The A900 expertly breaks in and conforms to your hand.
- 3. LOW PROFILE HEEL (FRONT SIDE):**  
Gives glove flexibility, opens up the palm and pocket, and makes it more forgiving on bad-hops.

NEW

PF



ALL POSITIONS 11.5"

STOCK NO.  
WTA09RB18115PF  
MSRP  
\$89.95

- H-Web
- Pedroia Fit™
- Brown with White

NEW



ALL POSITIONS 11.5"

STOCK NO.  
WTA09RB18115  
MSRP  
\$89.95

- H-Web
- Brown with White

NEW



ALL POSITIONS 11.75"

STOCK NO.  
WTA09RB181175  
WTA09LB181175 [LHT]  
MSRP  
\$89.95

- Pro Laced T-Web
- Brown with White

NEW



ALL POSITIONS 12.5"

STOCK NO.  
WTA09RB18125  
WTA08LB18125 [LHT]  
MSRP  
\$89.95

- Single Post Web
- Brown with White

NEW



1ST BASE 12"

STOCK NO.  
WTA09RB18BM12  
WTA09LB18BM12 [LHT]  
MSRP  
\$89.95

- Single Post Web
- Brown with White

NEW



CATCHER 34"

STOCK NO.  
WTA09RB18CM34  
MSRP  
\$89.95

- Half Moon Web
- Brown with White



# A500™

## FOR THE SERIOUS YOUNG PLAYER

The A500™ is the lightest all-leather glove on the market. The glove's top-grain leather provides a flexible, ready-to-play feel that performs without the extra weight of other leather gloves.

1. TOP GRAIN LEATHER:  
All the feel without the weight.
2. REAL LEATHER LACES:  
Tough and strong for maximum durability.
3. DOUBLE PALM CONSTRUCTION (FRONT SIDE):  
Keeps the pocket stable and wrinkle free.
4. ROLLED DUAL WELTING™:  
Thin strips of Pro Stock® leather are skived thin and rolled to provide long-lasting shape and a quicker break-in.

NEW



ALL POSITIONS 11"

STOCK NO.  
WTA05RB1811  
WTA05LB1811 [LHT]  
MSRP  
\$59.95

- H-Web
- Blonde and Black with Red

NEW



ALL POSITIONS 11.5"

STOCK NO.  
WTA05RB18115  
WTA05LB18115 [LHT]  
MSRP  
\$59.95

- H-Web
- Blonde and Black with Tropical Blue

NEW



ALL POSITIONS 12"

STOCK NO.  
WTA05RB1812  
WTA05LB1812 [LHT]  
MSRP  
\$59.95

- Basket Web
- Blonde with Dark Brown

NEW



ALL POSITIONS 12.5"

STOCK NO.  
WTA05RB18125  
WTA05LB18125 [LHT]  
MSRP  
\$59.95

- Single Post Web
- Grey and Black with Red

NEW



CATCHER 32"

STOCK NO.  
WTA05RB18CM  
MSRP  
\$59.95

- Half Moon Web
- Blond with Red



A450™



ALL POSITIONS 10.75"  
 STOCK NO.  
 WTA04RB17DP15  
 MSRP  
 \$39.95

- H-Web
- Black and Grey
- Youth Pattern



ALL POSITIONS 11"  
 STOCK NO.  
 WTA04RB17DW5  
 WTA04LB17DW5 [LHT]  
 MSRP  
 \$39.95

- Dual Post Web
- Grey, Orange and Royal
- Youth Pattern

NEW



ALL POSITIONS 11.5"  
 STOCK NO.  
 WTA04RB181787  
 MSRP  
 \$39.95

- H-Web
- Dark Brown and Blonde

NEW



ALL POSITIONS 12"  
 STOCK NO.  
 WTA04RB181799  
 WTA04LB181799 [LHT]  
 MSRP  
 \$39.95

- Dual Post Web
- Orange and Black

A360™



ALL POSITIONS 10"  
 STOCK NO.  
 WTA03RB1710  
 MSRP  
 \$29.95

- Victory Web with Weave
- Youth Pattern



ALL POSITIONS 11"  
 STOCK NO.  
 WTA03RB1711  
 WTA03LB1711 [LHT]  
 MSRP  
 \$34.95

- Corset Web
- Youth Pattern



ALL POSITIONS 11.5"  
 STOCK NO.  
 WTA03RB17115  
 MSRP  
 \$34.95

- Dual Post Web
- Youth Pattern



ALL POSITIONS 12"  
 STOCK NO.  
 WTA03RB1712  
 WTA03LB1712 [LHT]  
 MSRP  
 \$34.95

- 2-Piece Web



ALL POSITIONS 12.5"  
 STOCK NO.  
 WTA03RB17125  
 MSRP  
 \$34.95

- 2-Piece Closed Weave Web



CATCHER 31.5"  
 STOCK NO.  
 WTA03RB17CM315  
 WTA03LB17CM315 [LHT]  
 MSRP  
 \$44.95

- Half Moon Web
- Youth Pattern



CATCHER 32.5"  
 STOCK NO.  
 WTA03RB17CM325  
 WTA03LB17CM325 [LHT]  
 MSRP  
 \$44.95

- Half Moon Web
- Youth Pattern

A200™ MLB® TEAM GLOVE



ALL POSITIONS 10"  
 STOCK NO.  
 SEE LIST PRICE  
 MSRP  
 \$19.95

- H-Web
- Youth Pattern
- MLB Batter Logo version available in RHT and LHT
- All 30 Teams Available in RHT



**SIERRA ROMERO**  
USSSA Pride, 2B  
A2000 SR32 GM



**MONICA ABBOTT**  
NPF, P  
A2000 MA14 GM

# FASTPITCH GAME MODEL GLOVES



NEW  
GM  
SS

## SIERRA ROMERO

One of the best athletes in softball carries one of the hottest gamers. Sierra Romero's A2000® SR32 GM stands out with white SuperSkin and navy and red accents—the type of piece that's set to make a statement the way Sierra will for years to come.

INFIELD 12"

STOCK NO.  
WTA20RF18SR32GM  
MSRP  
\$259.95

### SIERRA'S GLOVE FEATURES

- Dual Post Web
- White SuperSkin™ with Navy and Red
- Sierra Romero Game Model



NEW  
GM  
SS

## MONICA ABBOTT

The greatest pitcher in softball deserves something special on her hand. When Monica Abbott steps into the circle, she'll be sporting the new A2000® MA14 GM, flush with red SuperSkin and a black 2-piece web. A glove to be the center of attention at the center of the diamond.

PITCHER 12.25"

STOCK NO.  
WTA20RF18MA14GM  
WTA20LF18MA14GM [LHT]  
MSRP  
\$259.95

### SIERRA'S GLOVE FEATURES

- 2-Piece Web
- Red Super Skin™ with Black
- Monica Abbott Game Model



## A2000® FASTPITCH RAISE YOUR GAME

A serious glove for a serious ballplayer. The Fastpitch A2000® line-up is created with the Custom Fit System so that every fastpitch player can have a glove that fits her hand—no matter how tight she wears it. The superior feel and durability come from the premium Pro Stock® leather that breaks in perfectly and lasts from one season to the next.

- 1. PRO STOCK® SELECT LEATHER:** Made specifically for Wilson ball gloves, this American Steerhide is preferred by professional players for its rugged durability and an unmatched feel.
- 2. WILSON® CUSTOM FIT SYSTEM:** Designed for optimal break-in. No creases, no matter how tight a player wears the glove.
- 3. NO STING ZONE:** Honeycomb Cell padding just below the pocket to absorb the shock of hard line drives and screaming throws.
- 4. COMFORT WRIST CLOSURE:** The new hook and loop wrist closure system offers a secure and comfortable fit.





**INFIELD** 11.75"  
 STOCK NO.  
 WTA20RF171175  
 MSRP  
 \$259.95

---

- H-Web
- White and Black



**INFIELD** 12"  
 STOCK NO.  
 WTA20RF171F12SS  
 MSRP  
 \$259.95

---

- Dual Post Web
- White with Black SuperSkin™

NEW  
 GM  
 SS



**INFIELD** 12"  
 STOCK NO.  
 WTA20RF18SR32GM  
 MSRP  
 \$259.95

---

- Dual Post Web
- White SuperSkin™ with Navy
- Sierra Romero Game Model
- Conventional Back



**INFIELD** 12"  
 STOCK NO.  
 WTA20RF17H12  
 MSRP  
 \$259.95

---

- H-Web
- White and Grey
- Conventional Back



**PITCHER** 12"  
 STOCK NO.  
 WTA20RF17P12  
 WTA20LF17P12 [LHT]  
 MSRP  
 \$259.95

---

- 2-Piece Closed Weave Web
- White and Black



**PITCHER** 12.25"  
 STOCK NO.  
 WTA20RF18MA14GM  
 WTA20LF18MA14GM [LHT]  
 MSRP  
 \$259.95

---

- 2-Piece Web
- Red SuperSkin™ with Black
- Monica Abbot Game Model
- Conventional Back

SS



**OUTFIELD** 12.5"  
 STOCK NO.  
 WTA20RF17V125SS  
 WTA20LF17V125SS [LHT]  
 MSRP  
 \$259.95

---

- Victory Web
- Black and White with Black SuperSkin™



**OUTFIELD** 12.5"  
 STOCK NO.  
 WTA20RF17V125WS  
 WTA20LF17V125WS [LHT]  
 MSRP  
 \$259.95

---

- Victory Web
- White and Grey with White SuperSkin™

SS



**OUTFIELD** 12.75"  
 STOCK NO.  
 WTA20RF151275SS  
 WTA20LF151275SS [LHT]  
 MSRP  
 \$259.95

---

- Dual Post Web
- Black and White with Black SuperSkin™



**1ST BASE** 12"  
 STOCK NO.  
 WTA20RF17BM12SS  
 WTA20LF17BM12SS [LHT]  
 MSRP  
 \$259.95

---

- Double Horizontal Bar Web
- Black and White with Black SuperSkin™

SS



**CATCHER** 34"  
 STOCK NO.  
 WTA20RF17CMSS  
 MSRP  
 \$259.95

---

- FPC Laced Web
- Open Back
- Black and White with Black SuperSkin™



# ONYX™

## FEELS GOOD. BREAKS IN FAST.

A favorite of Fastpitch players, the Onyx™ is so loved because it breaks in fast and feels good. It is diamond-ready and its Double Palm Construction helps provide the durability you need to last a long season.

1. **SOFT TUMBLED LEATHER:**  
Minimal break-in but lasting durability.
2. **ROLLED DUAL WELTING™:**  
Thin strips of Pro Stock® leather are skived thin and rolled to provide long-lasting shape and a quicker break-in.
3. **DOUBLE PALM CONSTRUCTION:**  
A thin, strategically cut piece of leather is placed between the palm liner and outer shell, providing maximum pocket stability.



**INFIELD** 11.75"  
STOCK NO.  
WTA12RF171175  
MSRP  
\$119.95

---

- Reinforced H-Web
- Soft Tumbled Leather



**PITCHER/INFIELD 12"**  
STOCK NO.  
WTA12RF1712  
WTA12LF1712 [LHT]  
MSRP  
\$119.95

---

- 2-Piece Closed Weave Web
- Soft Tumbled Leather



**PITCHER/OUTFIELD** 12.5"  
STOCK NO.  
WTA12RF17125  
WTA12LF17125 [LHT]  
MSRP  
\$119.95

---

- Victory Web
- Soft Tumbled Leather



**OUTFIELD** 12.75"  
STOCK NO.  
WTA12RF171275  
WTA12LF171275 [LHT]  
MSRP  
\$119.95

---

- Pro-Laced T-Web
- Soft Tumbled Leather



**CATCHER** 33"  
STOCK NO.  
WTA12RF1733  
MSRP  
\$119.95

---

- FPC Laced Web
- Soft Tumbled Leather



### AURA™

NEW



PITCHER/INFIELD 12"

STOCK NO.  
WTA09RF1812  
WTA09LF1812 [LHT]  
MSRP  
\$89.95

• 2-Piece Weave Web

NEW



OUTFIELD 12.5"

STOCK NO.  
WTA09RF18125  
WTA09LF18125 [LHT]  
MSRP  
\$89.95

• Victory Web

NEW



CATCHER 33"

STOCK NO.  
WTA09RF18FPCM  
MSRP  
\$89.95

• Dual Post Web

### SIREN™

NEW



ALL POSITIONS 11.5"

STOCK NO.  
WTA05RF18115  
WTA05LF18115 [LHT]  
MSRP  
\$59.95

• Corset Web

NEW



ALL POSITIONS 12"

STOCK NO.  
WTA05RF1812  
WTA05LF1812 [LHT]  
MSRP  
\$59.95

• 2-Piece Closed Weave Web

NEW



ALL POSITIONS 12.5"

STOCK NO.  
WTA05RF18125  
WTA05LF18125 [LHT]  
MSRP  
\$59.95

• Victory Web

### FLASH™



ALL POSITIONS 11"

STOCK NO.  
WTA04RF1611  
MSRP  
\$44.95

• Victory Web with Weave



ALL POSITIONS 11.5"

STOCK NO.  
WTA04RF16115  
WTA04LF16115 [LHT]  
MSRP  
\$44.95

• Corset Web



ALL POSITIONS 12"

STOCK NO.  
WTA04RF1612  
WTA04LF1612 [LHT]  
MSRP  
\$44.95

• Closed with V-Lace Web

# A2000<sup>®</sup> SLOWPITCH PATTERNS AND COLORS



Sure, the long ball wins games, but now you can flash the right equipment on defense too. Wilson<sup>®</sup> A2000<sup>®</sup> gloves are made just for the elite slowpitch player who takes the game seriously. With slowpitch-specific patterns and hot styling, there's no way the diamond won't notice.

1. PRO STOCK<sup>®</sup> LEATHER:  
Made specifically for Wilson ball gloves, this American Steerhide is preferred by professional players for its rugged durability and an unmatched feel.
2. DUAL WELTING<sup>™</sup>:  
Two strips of leather placed along each finger back create a durable pocket and a long lasting break-in.
3. GAP WELTING:  
On select patterns.



## ALL POSITIONS 13"

STOCK NO.  
WTA20RS1813SS  
WTA20LS1813SS [LHT]  
MSRP  
\$259.95

- Reinforced Single Post Ladder Web
- White SuperSkin<sup>™</sup> with Black and Metallic Gold
- New pattern featuring Gap Welting



## ALL POSITIONS 13.5"

STOCK NO.  
WTA20RS18135SS  
MSRP  
\$259.95

- Dual Post Web with Double Bar
- New pattern featuring Gap Welting

## A360<sup>™</sup>



## ALL POSITIONS 13"

STOCK NO.  
WTA03RS1713  
WTA03LS1713 [LHT]  
MSRP  
\$44.95

- Victory Web



## ALL POSITIONS 14"

STOCK NO.  
WTA03RS1714  
WTA03LS1714 [LHT]  
MSRP  
\$44.95

- Weave Web



GLOVE CARE



A2000® GLOVE CARE KIT

STOCK NO.	MSRP
WTA6763 TAN	\$49.99

Same kit used to repair A2000® gloves for MLB® players • Kit contains: Both black and tan rawhide lace, lacing tool, awl, cutters, threading needles, glove oil, brush and A2000 leather carry bag

A.



WTA6770 BLA

WTA6770 TAN

B.



WTA6764

A. PRO STOCK® GLOVE LACING KITS

STOCK NO.	MSRP
WTA6770 BLA: Black	\$14.99
WTA6770 TAN: Tan	\$14.99

Includes 60" of rawhide lace and one lacing needle

B. PREMIUM GLOVE OIL PDQ

STOCK NO.	MSRP
WTA6764	\$3.99

Easy to use spray applicator • Softens and aids glove break-in • 24 bottles per PDQ • Order in multiples of 24

C.



WTA6776

D.



WTA6778

C. PRO STOCK® GLOVE CONDITIONER PDQ

STOCK NO.	MSRP
WTA6776PD	\$9.99

Makes the break-in process easier with premium conditioner that conditions, cleans and restores • Order in multiples of 12

D. PRO STOCK® MINK OIL PASTE PDQ

STOCK NO.	MSRP
WTA6778PD	\$9.99

Extend the life of your Pro Stock® glove by using premium mink oil to restore and soften leather • Makes leather resistant to water and moisture • Order in multiples of 12

SLOWPITCH GLOVES

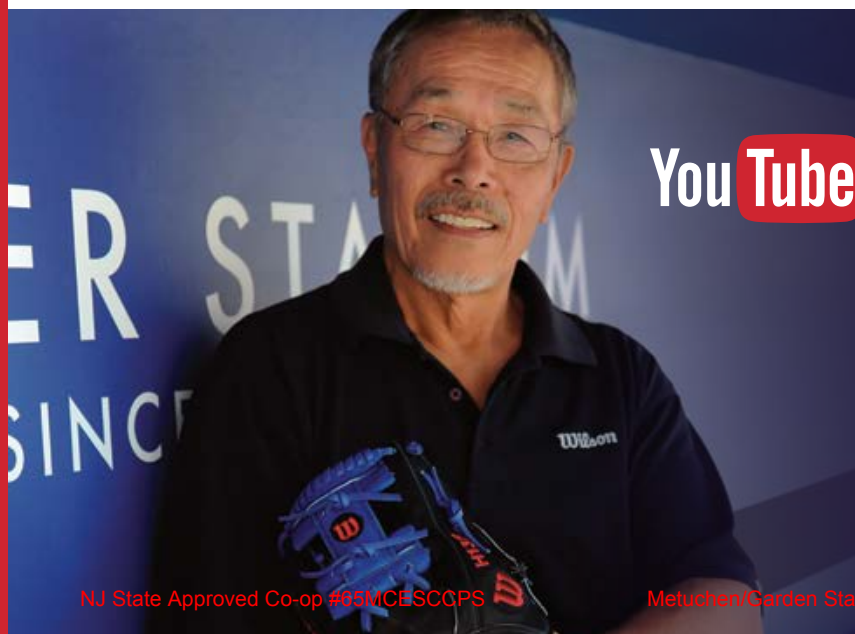

You **Tube**

GLOVE CARE TIPS FROM THE GURU

WILSON® GLOVE MASTER CRAFTSMAN SHIGEAKI ASO SHOWS YOU ALL THE WAYS TO LOVE YOUR GLOVE AT [WWW.YOUTUBE.COM/WILSONBALLGLOVES](http://WWW.YOUTUBE.COM/WILSONBALLGLOVES)

PROTECTIVE

GEAR

PROTECTIVE



THE OFFICIAL CATCHER'S PROTECTIVE GEAR  
OF MAJOR LEAGUE BASEBALL



# PRO STOCK® CATCHER'S GEAR

## WEAR PROTECTION

When safety is a priority, comfort doesn't have to be an afterthought. Wilson® Pro Stock Catcher's Gear is designed for durability and sturdiness, but built with style and feel in mind.



### PRO STOCK® CATCHER'S HELMET

STOCK NO.	SIZE	COLOR	MSRP
WTA5700BLLX	Large/X Large	Black	\$159.99
WTA5700BLSM	Small/Medium	Black	\$159.99
WTA5700NALX	Large/X Large	Navy	\$159.99
WTA5700NASM	Small/Medium	Navy	\$159.99
WTA5700ROLX	Large/X Large	Royal	\$159.99
WTA5700ROSM	Small/Medium	Royal	\$159.99
WTA5700SCLX	Large/X Large	Scarlet	\$159.99
WTA5700SCSM	Small/Medium	Scarlet	\$159.99

SIZES: S-M [6-1/8-7-1/4], L-XL [7-7-1/2]

Low profile facemask for increased visibility • Vented helmet shell for maximum breathability • Removable interior padding for washing • Moisture wicking fabric on interior pads • Two-tone color combinations • Meets NOCSAE® protection standard



Manufacturer Certifies



### PRO STOCK® CHEST PROTECTOR

STOCK NO.	SIZE	COLOR	MSRP
WTA4700BLLG	Large	Black	\$139.99
WTA4700BLMD	Medium	Black	\$129.99
WTA4700BLSM	Small	Black	\$129.99
WTA4700NALG	Large	Navy	\$139.99
WTA4700NAMD	Medium	Navy	\$129.99
WTA4700NASM	Small	Navy	\$129.99
WTA4700ROLG	Large	Royal	\$139.99
WTA4700ROMD	Medium	Royal	\$129.99
WTA4700ROSM	Small	Royal	\$129.99
WTA4700SCLG	Large	Scarlet	\$139.99
WTA4700SCMD	Medium	Scarlet	\$129.99
WTA4700SCSM	Small	Scarlet	\$129.99

SIZES: Large 16.5", Medium 15.5", Small 14.5"

High quality memory foam to help reduce rebound • Angled pads to help block the ball straight down • Internal PE plates in the throat, collarbone and sternum for added protection • Perforated foam for maximum breathability • Molded removable shoulder caps for increased mobility • Gunmetal finish metal hardware



### PRO STOCK® LEG GUARDS

STOCK NO.	SIZE	COLOR	MSRP
WTA3700BLLG	Large	Black	\$159.99
WTA3700BLMD	Medium	Black	\$149.99
WTA3700BLSM	Small	Black	\$149.99
WTA3700NALG	Large	Navy	\$159.99
WTA3700NAMD	Medium	Navy	\$149.99
WTA3700NASM	Small	Navy	\$149.99
WTA3700ROLG	Large	Royal	\$159.99
WTA3700ROMD	Medium	Royal	\$149.99
WTA3700ROSM	Small	Royal	\$149.99
WTA3700SCLG	Large	Scarlet	\$159.99
WTA3700SCMD	Medium	Scarlet	\$149.99
WTA3700SCSM	Small	Scarlet	\$149.99

SIZES: Large 17.5", Medium 16", Small 14.5"

Overlapping thigh pieces for ultimate protection • Perforated foam provides maximum breathability • Inner padding protects knees and shins during blocking and is removable for washing • Lightweight for increased mobility

PROTECTIVE

# C1K™ CATCHER'S GEAR

## PRO-INSPIRED PROTECTION

Modeled after Wilson® Pro Stock Catcher's Gear, C1K™ Catcher's Gear is designed for durability and sturdiness, but built with MLB® Pro style and feel in mind. Whether you're an adult or intermediate player, the C1K™ Catcher's Set will protect you all season long.



Manufacturer Certifies (Helmet)



### C1K™ CATCHER'S GEAR KIT ADULT

(RECOMMENDED FOR AGES 15+)

STOCK NO.	SIZE	COLOR	MSRP
WTA4601BLADT	Adult	Black	\$299.99
WTA4601SCADT	Adult	Scarlet	\$299.99
WTA4601NAADT	Adult	Navy	\$299.99
WTA4601NSADT	Adult	Navy/Scarlet	\$299.99
WTA4601ROADT	Adult	Royal	\$299.99
WTA4601BOADT	Adult	Black/Orange	\$299.99
WTA4601SWADT	Adult	Silver/White	\$299.99

### C1K™ CATCHER'S GEAR KIT INTERMEDIATE

(RECOMMENDED FOR AGES 12-15)

STOCK NO.	SIZE	COLOR	MSRP
WTA4602BLINT	Intermediate	Black	\$249.99
WTA4602SCINT	Intermediate	Scarlet	\$249.99
WTA4602NAINT	Intermediate	Navy	\$249.99
WTA4602NSINT	Intermediate	Navy/Scarlet	\$249.99
WTA4602ROINT	Intermediate	Royal	\$249.99
WTA4602BOINT	Intermediate	Black/Orange	\$249.99
WTA4602SWINT	Intermediate	Silver/White	\$249.99

#### Kit Includes:

Catcher's Helmet, Chest Protector and Leg Guards

#### Helmet:

Glossy finish • Removable moisture wicking chin pad • Adjustable straps for custom fit • Meets NOCSAE® protection standard

SIZES: Adult [7½-7¾], Intermediate [6¾-7¼]

#### Chest Protector:

High-density foam padding for ultimate comfort and protection • Removable shoulder caps for increased mobility • Over-the-shoulder adjustable harness • Precision, angled pad design to help block the ball straight down

SIZES: Adult [15"], Intermediate [13.5"]

#### Leg Guards:

Inner knee pad protects knees, removable for washing • Overlapping thigh pieces for maximum protection • Lightweight premium grade ABS plastic • Adjustable metal buckles for easy on/off and snug fit

SIZES: Adult [15.5"], Intermediate [14"]



### AVAILABLE IN COLORS



BL BLACK BO BLACK/ORANGE NA NAVY NS NAVY/SCARLET RO ROYAL SW SILVER/WHITE SC SCARLET



# PRESTIGE™ CATCHER'S GEAR

## PRO-INSPIRED PROTECTION BEHIND THE PLATE

Modeled after Wilson® MLB® catchers' gear, Prestige™ has a multiple point adjustment system that expertly keeps the gear in place. It's flexible to naturally move and protect as the player moves.



Manufacturer Certifies



### PRESTIGE™ CATCHER'S HELMET

STOCK NO.	SIZE	COLOR	MSRP
WTA558000LX	L/XL [7-7½]	Black	\$64.99
WTA558000SM	S/M [6-7]	Black	\$59.99

Premium grade ABS shell with glossy finish • Venting technology to maintain protection while keeping your head cool • Meets NOCSAE protection standard



View with tail



### PRESTIGE™ CHEST PROTECTOR

STOCK NO.	SIZE	COLOR	MSRP
WTA3303BL18	Adult 16"	Black	\$42.00
WTA3303BL16	Intermediate 14"	Black	\$38.00
WTA3303BL14	Youth 12"	Black	\$33.50

Gear designed specifically for League Play • Form fitting design modeled after Wilson® MLB® Catcher's Gear • Removable shoulder cap and tail (14" and 12" sizes sold with tail) • Multi-point adjustment system



Back view



### PRESTIGE™ LEG GUARDS

STOCK NO.	SIZE	COLOR	MSRP
WTA3503BL17	Adult 17"	Black	\$56.00
WTA3503BL15	Intermediate 15"	Black	\$50.00
WTA3503BL13	Youth 13"	Black	\$42.00

Gear designed specifically for League Play • Form fitting design modeled after Wilson® MLB® Catcher's Gear • Forward facing clips for easy off and on • Double knee cap design for maximum protection

# EZ GEAR™ KIT

## CATCHER IN THE BLINK OF AN EYE

Wilson EZ Gear™ is built with QuickChange™ technology for easy on-and-off in ten seconds or less. Each EZ Gear™ Kit includes a protective helmet, chest protector and set of leg guards.



MEETS NOCSAE STANDARD  
Manufacturer Certifies



MEETS NOCSAE STANDARD  
Manufacturer Certifies



### EZ GEAR™ KIT L/XL

(L/XL RECOMMENDED FOR AGES 7-12)

STOCK NO.	SIZE	COLOR	MSRP
WTA368400LX	L/XL	Black	\$119.99
WTA368700LX	L/XL	Navy	\$119.99
WTA368800LX	L/XL	Royal	\$119.99
WTA368900LX	L/XL	Scarlet	\$119.99

### EZ GEAR™ KIT S/M

(S/M RECOMMENDED FOR AGES 5-7)

STOCK NO.	SIZE	COLOR	MSRP
WTA368400SM	S/M	Black	\$99.99
WTA368700SM	S/M	Navy	\$99.99
WTA368800SM	S/M	Royal	\$99.99
WTA368900SM	S/M	Scarlet	\$99.99

Kit Includes:  
Chest Protector, Leg Guards and Catcher's Helmet

Helmet:  
Premium grade ABS shell with glossy finish • Venting technology to maintain protection while keeping your head cool • Meets NOCSAE protection standard

SIZES: L/XL [7-7<sup>7</sup>/<sub>8</sub>], S/M [6-7]

Chest Protector:  
One-time adjustable QuickChange™ system – set it and forget it • Form fitting design modeled after Wilson™ MLB® Catcher's Gear • Removable shoulder caps • Multi-point adjustment system

SIZES: L/XL [13"], S/M [11"]

Leg Guards:  
One-time adjustable QuickChange™ system – set it and forget it • Form fitting design modeled after Wilson™ MLB® Catcher's Gear • Forward facing clips for easy on and off

SIZES: L/XL [12"], S/M [10½"]

### AVAILABLE IN COLORS



## PRODUCT SIZING

Different size catchers need different size gear. Be sure to select the chest protector and leg guard size that fits you best.

1. Take body measurements
2. Match body measurement length in inches to closest numbers in the product description

### HELMET SIZE CHART

54	55	56	57	58	59	60	CM
21 ¼	21 ⅝	22	23 ⅜	22 ¾	23 ⅛	23 ½	IN
6 ¾	6 ⅞	7	7 ¼	7 ¼	7 ⅜	7 ½	HAT SIZE







OKLAHOMA  
STATE  
UNIVERSITY  
Sleek™ Pro Skull Cap

## OLD SCHOOL™ CATCHER'S GEAR



Non wrap around pads.



Back view



Dri-Lex™ liner wicks away moisture.



DYNA-LITE™ STEEL CATCHER'S FACEMASK  
with NON WRAP-AROUND PADS

STOCK NO.  
WTA3010

MSRP  
\$69.99

PU coated steel wire • Non wrap-around pads for closer fit • Premium leather lining



SLEEK™ PRO SKULL CAP

STOCK NO.  
WTA3123

MSRP  
\$29.99

SIZE: One Size Fits Most [7-7<sup>5</sup>/<sub>8</sub>]

Premium rubberized matte finish • For catchers and base coaches • Dri-Lex™ moisture management liner • Strategic venting reduces weight and maximizes air flow



OLD SCHOOL™ CATCHER'S SKULL CAP

STOCK NO.  
WTA3122

MSRP  
\$19.99

SIZE: One Size Fits Most [7-7<sup>5</sup>/<sub>8</sub>]

Premium Foam padding wrapped with moisture management fabric • Glossy finish



THROAT PROTECTOR

STOCK NO.  
WTA3901 BLA: 6"  
WTA3902 BLA: 4"

MSRP  
\$9.99  
\$9.99

Attaches to New View™ and Dyna-Lite™ Facemasks • Header card and poly bag packaging

# UMPIRE GEAR

**JOE WEST**  
MLB UMPIRE

Dyna-Lite™ Steel Facemask  
Pro Gold™ Chest Protector  
Pro Gold™ Leg Guards



THE OFFICIAL UMPIRE PROTECTIVE GEAR  
OF MAJOR LEAGUE BASEBALL





# UMPIRE CHEST PROTECTORS



Winged wrap-around padding for extra protection



Extra side protection



### PRO GOLD™ CHEST PROTECTOR

STOCK NO.	SIZE	COLOR	MSRP
WTA3210 BLA S-M	11"	Black	\$209.99
WTA3210 BLA M-L	12"	Black	\$209.99
WTA3210 BLA L-X	12¾"	Black	\$209.99

The ultimate in umpire protection • Fitted with extra side padding for extra comfort and protection



Extra neck padding



### PRO PLATINUM™ CHEST PROTECTOR

STOCK NO.	SIZE	COLOR	MSRP
WTA3215 CHA12	12"	Charcoal	\$199.99
WTA3215 CHA1075	10¾"	Charcoal	\$199.99

Fitted Protector with extra side padding and neck pad for comfort and protection • Conforms at the shoulders



Removable armor and washable lining



### FITTED CHEST PROTECTOR

STOCK NO.	SIZE	COLOR	MSRP
WTA3217 CHA13	13"	Charcoal	\$119.99

Patented adjustable breastplate for optimal fit • Hook & loop padding for easier maintenance • Added shoulder plate for protection • Stitched plastic for added durability



Hook & loop keeps straps secure to chest protector

# UMPIRE LEG GUARDS



Bridged Comfort System™



### PRO GOLD™ LEG GUARDS

STOCK NO.	SIZE	COLOR	MSRP
WTA3409 WV16-17	16-17"	Black	\$139.99
WTA3409 WV18-19	18-19"	Black	\$139.99

Expanded adjustable ankle plates • Reinforced padding along shin • Removable padding for easy cleaning • Adjustable triple-kneecap design for precise fit and extra coverage • Bridged Comfort System™ relieves knees while adding maximum protection



Expanded ankle plates



### PRO PLATINUM™ LEG GUARDS

STOCK NO.	SIZE	COLOR	MSRP
WTA3417 CHA185	18½"	Charcoal	\$129.99
WTA3417GR	17"	Charcoal	\$129.99
WTA3417 CHA155	15½"	Charcoal	\$129.99

Lower profile design • Flared, adjustable ankle plates • Reinforced padding along shin • Removable padding for easy cleaning • Adjustable double kneecap design for precise fit

# GUARDIAN™ UMPIRE GEAR



Back View



### GUARDIAN™ CHEST PROTECTOR

STOCK NO.	SIZE	COLOR	MSRP
WTA322013	13"	Black	\$79.99
WTA322011	11"	Black	\$79.99

SoftShell form fitting design • Aegis antimicrobial treatment • Spacer mesh lining for breathability to keep you cool • PE sheets, memory and EVA foam provide the necessary protection where you need it most • Removable/adjustable shoulder caps



Back View









### GUARDIAN™ LEG GUARDS

STOCK NO.	SIZE	COLOR	MSRP
WTA342170	17"	Black	\$64.99
WTA342155	15.5"	Black	\$64.99



Triple knee cap design for added protection • Removable toe cap • Aegis antimicrobial treatment • Vented in the right place for maximum airflow, keeping you cool



UMPIRE FACEMASKS	DYNA-LITE™				NEW VIEW™
	 [57g]	 [549g]	 [757g]	 [759g]	 [688g]
<b>STOCK NO.</b>	WTA3009TI	WTA3009AL	WTA3017 BLA	WTA3009XBLA WV	WTA3077 BLST
<b>CAGE MATERIAL</b>	TITANIUM	ALUMINUM	STEEL	STEEL	STEEL
<b>PAD MATERIAL</b>	Two Tone, Black PU and Tan Leather	Memory Foam Pads Wrapped in Moisture Wicking Fabric	Absorbent Synthetic Inner, PU Outer	Two Tone, Black PU and Tan Leather	Two Tone, Black PU and Tan Leather
<b>MSRP</b>	\$279.99	\$139.99	\$69.99	\$79.99	\$99.99

UMPIRE REPLACEMENT PADS	 [133g]	 [151g]	 [123g]
<b>STOCK NO.</b>	WTA3816BL	WTA3816TN	WTA3817BL
<b>PAD MATERIAL</b>	Outer PU, Inner Full Grain Tan Leather	Full Grain Leather	Memory Foam Pads Wrapped in Moisture Wicking Fabric
<b>PAD TYPE</b>	Non Wrap Around	Non Wrap Around	Non Wrap Around
<b>MSRP</b>	\$49.99	\$49.99	\$29.99

All replacement pads are compatible with Wilson New View™ and Dyna-Lite™ Facemasks.

UMPIRE HELMETS	PRO STOCK™	
	 [979g]	 [1190g]
<b>STOCK NO.</b>	WTA5800BL	WTA5801BL
<b>CAGE MATERIAL</b>	TITANIUM	STEEL
<b>PAD TYPE</b>	Removable Moisture-Wicking Pads	Removable Moisture-Wicking Pads
<b>MSRP</b>	\$329.99	\$159.99





# COACH ACCESSORIES



### LINE-UP CARDS

STOCK NO.  
WTA6761

MSRP  
\$17.99

Boxed Lineup Cards (30 pack)

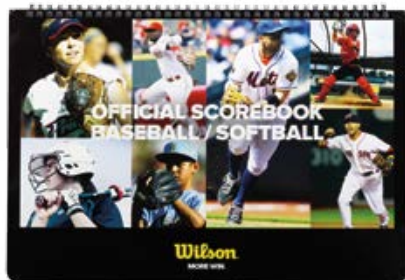

### SPIRAL SCOREBOOK

STOCK NO.  
WTA3753

MSRP  
\$9.99

New, easy to read format • Includes pitch counter • Enough pages to record 30 games

# UMPIRE ACCESSORY



### UMPIRE KIT

STOCK NO.  
WTA6754

MSRP  
\$9.99

Includes umpire brush, ball strike counter and ball bag

# BASE BALLS

# SOFT BALLS

- Allegheny Mountain Collegiate Conference (AMCC)
- American Athletic Conference (AAC)
- American Legion
- Berkshire Adult Baseball
- Big East Conference
- Big South Conference
- Capital Athletic Conference (CAC)
- Centennial Conference
- Colonial Athletic Association (CAA)
- Colorado Fireworks Tournament
- Commonwealth Coast Conference (CCC)
- Conference Carolinas (CC)
- East Cobb Baseball
- FIBS (Italy Cup)
- Fort Collins Baseball Club (FCBC)
- Georgia Collegiate Athletic Conference (GCAA)
- Great Northwest Athletic Conference (GNAC)
- Great Midwest Athletic Conference (GMAC)
- Gulf South Conference (GSA)
- Junior Baseball Organization (JBO)
- Maple Zone Institution
- Mid-America Intercollegiate Athletics Association (MIAA)
- Middle Atlantic Conference (MAC)
- Minnesota Intercollegiate Athletic Conference (MIAC)
- Mississippi Association of Community & Junior Colleges (MACJC)
- NABA (WFSA)
- National Adult Baseball Association (NABA)
- National Christian College Athletic Association (NCCAC)
- National Fastpitch Coaches Association (NFCA)
- NJCAA Region X
- North Coast Athletic Conference (NCAC)
- Northern Sun Intercollegiate Conference (NSIC)
- Ohio Valley Conference (OVC)
- Peach Belt Conference (PBC)
- Pennsylvania State Athletic Conference (PSAC)
- PONY License
- Premier Baseball League (PBL)
- Rocky Mountain USSSA
- Sioux Empire Baseball Association (SEBA)
- South Atlantic Conference (SAC)
- South Carolina USSSA
- Southern Conference (SoCon)
- Summit League
- Sunbelt Conference
- Sunshine State Conference (SSC)
- Tennessee Baseball Coaches Association (TBCA)
- Tennessee Community College Athletic Association (TCCAA)
- Triple Crown Sports
- Wisconsin Intercollegiate Athletic Conference (WIAC)

## CONFERENCE AND LEAGUE ADOPTIONS

## HIGH SCHOOL STATE ADOPTIONS

- Alabama – AHSAA
- Arizona – AIA
- Arkansas – AAA
- California – CIF
- Central Coast Section
- California – CIF North Coast
- California – CIF
- San Joaquin Section
- Colorado – CHSAA
- Delaware – DIAA
- Florida – FHSAA
- Georgia – GHSA
- Illinois – IHSA, IHSBCA
- Indiana – IHSAA
- Maryland – MIAA
- Maryland – MPSSAA
- Michigan – DCL
- Michigan – MHSAA
- Mississippi – MAIS, MHSAA
- Missouri – MHSAA
- Nevada – NIAA
- New Jersey – NJSIAA
- New Mexico – NMAA
- North Carolina – NCHSAA, NCISAA
- Oklahoma – OSSAA
- Oregon – OSAA
- Tennessee – TSSAA
- Texas – TAPPS
- Utah – UHSAA
- Virginia – VHSL
- Virginia – VISAA
- West Virginia – WVSSAC





DURA-CORE TECHNOLOGY™

RED CUSHIONED CORK



SUPER SEAM TECHNOLOGY™



FLAT SEAMS

# CORES BASEBALL

# SEAMS BASEBALL

### DURA-CORE TECHNOLOGY™:

Added to Red Cushioned Cork to help the ball retain hardness 15% better than the competition. Formed to withstand impact and give you the game changing performance you need.

### RED CUSHIONED CORK:

Gives a Wilson® baseball the ability to keep its shape and firmness. This allows for better pop when coming off the bat.

### SUPER SEAM TECHNOLOGY™:

With seams 20% higher than raised seam baseballs, pitchers experience superior control on the mound. Fielders can locate the ball quicker in their glove and throw with more accuracy.

### FLAT SEAMS:

The most aerodynamic Wilson baseball, these balls fly further, giving both pitchers and hitters a true feel of the ball.



## PRO SERIES: COLLEGIATE AND HIGH SCHOOL ELITE GAME PLAY

### A1001

STOCK NO.  
WTA1001BFS  
MSRP  
\$88.99

COVER  
Grade A Full Grain Leather

SEAM WINDS  
Flat Premium Gray and White Wool

CENTER  
Red Cushioned Cork with  
Dura-Core Technology™



### A1010 PRO

STOCK NO.  
WTA1010BPROFS (will not have NFHS stamp)  
WTA1010BPROSST  
MSRP  
\$82.99

COVER  
Grade A Full Grain Leather

SEAM WINDS  
SST Premium Gray Wool  
Flat Premium Gray Wool

CENTER  
Red Cushioned Cork with  
Dura-Core Technology™



### A1010 HS1

STOCK NO.  
WTA1010BHS1SST  
MSRP  
\$72.99

COVER  
Grade B Full Grain Leather

SEAM WINDS  
SST Gray Wool

CENTER  
Red Cushioned Cork with  
Dura-Core Technology™



### A1010 HS1 AMERICAN LEGION

STOCK NO.  
WTA1010BHS1AL1  
MSRP  
\$72.99

COVER  
Grade B Full Grain Leather

SEAM WINDS  
SST Gray Wool

CENTER  
Red Cushioned Cork with  
Dura-Core Technology™



### AVAILABLE IN RETAIL PACK

STOCK NO.  
WTA1010THS1SST  
\$75.95

### A1015

STOCK NO.  
WTA1015BSST  
MSRP  
\$59.99

COVER  
Grade C Full Grain Leather

SEAM WINDS  
SST Gray Wool

CENTER  
Red Cushioned Cork with  
Dura-Core Technology™



### CHAMPION SERIES: GAME PLAY AND PRACTICE

A1020  
STOCK NO.  
WTA1020BSST  
MSRP  
\$56.99

COVER  
Grade C  
Full Grain Leather  
SEAM WINDS  
SST Gray Wool

CENTER  
Red Cushioned Cork with  
Dura-Core Technology™



A1030  
STOCK NO.  
WTA1030B  
WTA1030BFS  
MSRP  
\$48.99

COVER  
Grade C/D  
Full Grain Leather

SEAM WINDS  
SST Gray Wool  
Flat Gray Wool

CENTER  
Red Cushioned Cork



A1035  
STOCK NO.  
WTA1035B  
MSRP  
\$47.99

COVER  
Grade C/D  
Full Grain Leather

SEAM WINDS  
SST Gray Wool

CENTER  
Black Cork & Rubber

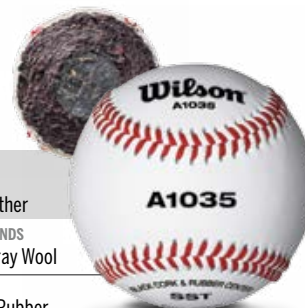

### TOURNAMENT SERIES: YOUTH LEAGUE ELITE GAME PLAY

SST SERIES  
AVAILABLE WITH  
THE FOLLOWING  
STAMPS:

MSRP  
\$54.99

COVER  
Grade C/D Full Grain Leather

SEAM WINDS  
SST Gray Wool

CENTER  
Red Cushioned Cork



### LEAGUE SERIES: YOUTH LEAGUE GAME PLAY

1 SERIES  
AVAILABLE WITH  
THE FOLLOWING  
STAMPS:

MSRP  
\$47.99

COVER  
Grade C/D Full Grain Leather

SEAM WINDS  
SST Gray Wool

CENTER  
Black Cork & Rubber





## PRACTICE BALLS

A1060

STOCK NO.  
WTA1060B

MSRP  
\$42.99

COVER  
White Split Leather

SEAM WINDS  
SST Gray Wool

CENTER  
Cork and Rubber



A1274

COVER  
White Split Leather

SEAM  
SST

CENTER  
Cork and Rubber

**AVAILABLE IN RETAIL PACK ONLY**

STOCK NO.  
WTA1274T      WTA1274WSHRINK  
\$45.00      \$47.00



## RETAIL SERIES

A1250

COVER  
Synthetic Leather

SEAM  
Flat

CENTER  
Cork and Rubber

HITS  
Good for up to 15 hits

**AVAILABLE IN RETAIL PACK ONLY**

STOCK NO.  
WTA1250T  
\$31.00



A1210

COVER  
Synthetic Leather

SEAM  
Flat

CENTER  
Cork and Rubber

HITS  
Good for up to 10 hits

**AVAILABLE IN RETAIL PACK ONLY**

STOCK NO.  
WTA1210T  
\$28.00



A1150

COVER  
Dura-Lon Synthetic Leather

SEAM  
Flat

CENTER  
Cortex™

HITS  
This ball is NON-HITTABLE

**AVAILABLE IN RETAIL PACK ONLY**

STOCK NO.  
WTA1150T      WTA1150WSHRINK  
\$29.00      \$28.00





# SOFT COMPRESSION BASEBALLS

A sponge center creates a soft compression ball that makes youth play and indoor training more successful.

LEVEL 1:  
93% softer than  
traditional baseballs

LEVEL 5:  
85% softer than  
traditional baseballs

A1217

STOCK NO.  
WTA1217B

MSRP  
\$34.99

COVER  
Synthetic Leather

SEAM LEVEL  
Flat 1

CENTER  
Sponge Center

**AVAILABLE IN RETAIL PACK**

STOCK NO.  
WTA1217T  
\$15.00



A1228

STOCK NO.  
WTA1228B

MSRP  
\$34.99

COVER  
Synthetic Leather

SEAM LEVEL  
Flat 5

CENTER  
Sponge Center

**AVAILABLE IN RETAIL PACK**

STOCK NO.  
WTA1228T  
\$39.00



## PRACTICE BUCKETS

A1098 X-OUT  
BUCKET COMBO

STOCK NO.  
WTA1098 X-OUT

MSRP  
\$153.99

CONTENTS  
3 Dozen A1010S Balls;  
1 A3948 Ball Bucket

A1098 1030  
BUCKET COMBO

STOCK NO.  
WTA1098 1030

MSRP  
\$146.99

CONTENTS  
3 Dozen A1030 Balls;  
1 A3948 Ball Bucket



BALL BUCKET WITH LID

STOCK NO.  
WTA3948

MSRP  
\$19.99

Holds 4 Dozen Baseballs





# CUSTOM LOGOS & SEAMS

The options for game balls and practice balls are endless with Wilson® custom baseballs and softballs. Hit up your local team dealer or Territory Manager with your logo and seam color choices to place an order.

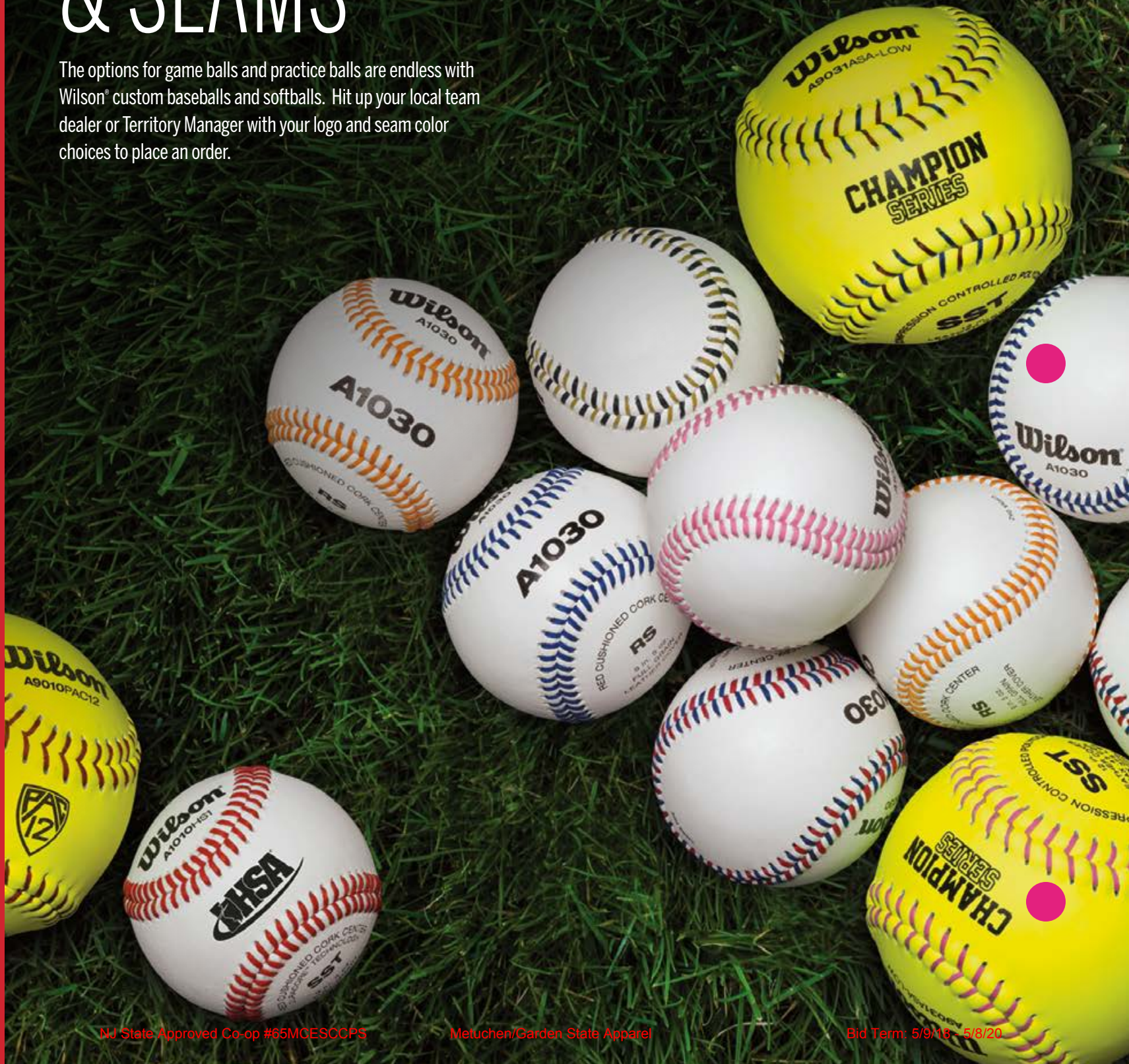





COMPRESSION CONTROLLED POLYCORE

COMPRESSION CONTROLLED CORK



SUPER SEAM TECHNOLOGY™

# CORES SOFTBALL

## COMPRESSION CONTROLLED POLYCORE:

The most consistent playing softball in the world. Polycore softballs don't break down as quickly; giving you unmatched durability for performance that can't be beat.

## COMPRESSION CONTROLLED CORK:

Exclusive to Wilson®, this softball gives you the traditional feel you need at the price you want.

# SEAMS SOFTBALL

## SUPER SEAM TECHNOLOGY™:

With seams 20% higher than conventional seamed softballs, pitchers experience superior control on the mound. Fielders are more fierce as they locate the ball quicker in their glove and throw with more accuracy.

## COLLEGIATE AND HIGH SCHOOL

A9010

STOCK NO.  
WTA9010BSST: 12"

MSRP  
\$90.99

COVER  
Leather  
Freq. Matched Optic Yellow\*

SEAM	STITCH	COR	COMP.
SST	Red	.47	400 lbs.

CENTER  
Compression Controlled Polycore



A9011

STOCK NO.  
WTA9011BSST: 12"

MSRP  
\$83.99

COVER  
Leather  
Freq. Matched Optic Yellow\*

SEAM	STITCH	COR	COMP.
SST	Red	.47	375 lbs.

CENTER  
Compression Controlled Polycore



**NFHS®**

A9016

STOCK NO.  
WTA9016BSST: 12"

MSRP  
\$83.99

COVER  
Leather  
Freq. Matched Optic Yellow\*

SEAM	STITCH	COR	COMP.
SST	Red	.47	375 lbs.

CENTER  
Compression Controlled Cork



**NFHS®**

A9244

STOCK NO.  
WTA9244BNFHSYR: 11"

MSRP  
\$83.99

COVER  
Leather  
Freq. Matched Optic Yellow\*

SEAM	STITCH	COR	COMP.
Flat	Red	.44	375 lbs.

CENTER  
Compression Controlled Polycore



**NFHS®**



### ASA®

#### ASA® SERIES

STOCK NO.  
WTA9031BASA-LOW: 12"  
WTA9231BASA-LOW: 11"

MSRP  
\$77.99

COVER  
Leather  
Freq. Matched Optic Yellow\*

SEAM	STITCH	COR	COMP.
SST	Red	.47	375 lbs.

CENTER  
Compression Controlled Polycore

STOCK NO.  
WTA9131BASA-LOW: 12"  
WTA9331BASA-LOW: 11"

MSRP  
\$63.99: 12" \$63.99: 11"

COVER  
Synthetic Leather  
Freq. Matched Optic Yellow\*

SEAM	STITCH	COR	COMP.
SST	Red	.47	375 lbs.

AVAILABLE IN RETAIL PACK

STOCK NO.  
WTA9031TASA-LOW  
\$65.99



#### ASA® SERIES

STOCK NO.  
WTA9060BASA-LOW: 12"  
WTA9260BASA-LOW: 11"

MSRP  
\$77.99

COVER  
Leather  
Freq. Matched Optic Yellow\*

SEAM	STITCH	COR	COMP.
SST	Red	.47	375 lbs.

CENTER  
Compression Controlled Cork

STOCK NO.  
WTA9106BASA-LOW: 12"  
WTA9306BASA-LOW: 11"

MSRP  
\$54.49: 12" \$53.99: 11"

COVER  
Synthetic Leather  
Freq. Matched Optic Yellow\*

SEAM	STITCH	COR	COMP.
SST	Red	.47	300 lbs.

AVAILABLE IN RETAIL PACK

STOCK NO.  
WTA9106TASA-LOW WTA9306TASA-LOW  
\$55.38 \$56.38



### USSSA®

#### USSSA® SERIES

STOCK NO.  
WTA9033BUSSFPYB: 12"  
WTA9233BUSSFPYB: 11"

MSRP  
\$77.99

COVER  
Leather  
Freq. Matched Optic Yellow\*

SEAM	STITCH	COR	COMP.
SST	Blue	.47	375 lbs.

CENTER  
Compression Controlled Polycore



#### USSSA® SERIES

STOCK NO.  
WTA9133BUSSFPYB: 12"  
WTA9333BUSSFPYB: 11"

MSRP  
\$63.99: 12" \$63.99: 11"

COVER  
Synthetic Leather  
Freq. Matched Optic Yellow\*

SEAM	STITCH	COR	COMP.
SST	Blue	.47	375 lbs.

CENTER  
Compression Controlled Polycore



### YOUTH LEAGUE

#### LITTLE LEAGUE®

STOCK NO.  
WTA9074BSST: 12"  
WTA9274BSST: 11"

MSRP  
\$75.99

COVER  
Leather  
Freq. Matched Optic Yellow\*

SEAM	STITCH	COR	COMP.
SST	Red	.47	375 lbs.

CENTER  
Compression Controlled Polycore



Little League.

#### PONY™ LEAGUE

STOCK NO.  
WTA9075BSST: 12"  
WTA9275BSST: 11"

MSRP  
\$75.99

COVER  
Leather  
Freq. Matched Optic Yellow\*

SEAM	STITCH	COR	COMP.
SST	Red	.47	375 lbs.

CENTER  
Compression Controlled Polycore



# TRAINING

## RECREATIONAL

STOCK NO.  
WTA9150T: 12"

MSRP  
\$46.00

COVER  
Synthetic Leather  
Freq. Matched Optic Yellow\*

SEAM STITCH  
Flat Red

CENTER  
Compression Controlled Cork

STOCK NO.  
WTA9250T0: 11"

MSRP  
\$46.00

COVER  
Synthetic Leather  
Freq. Matched Optic Yellow\*

SEAM STITCH  
Flat Red

CENTER  
Compression Controlled Cork



## SOFT COMPRESSION

STOCK NO.  
WTA9117B: 12"  
WTA9317B: 11"

MSRP  
\$55.99: 12" \$54.99: 11"

COVER  
Ultra Grip™  
Freq. Matched Optic Yellow\*

SEAM STITCH LEVEL  
SST Red 1

CENTER  
Sponge Center



### AVAILABLE IN RETAIL PACK

STOCK NO.	STOCK NO.
WTA9117T	WTA9317T
MSRP	MSRP
\$58.50	\$55.38

## BALL BUCKET

STOCK NO.  
WTA394700

MSRP  
\$19.99

Holds 2 Dozen Softballs





GEAR BAGS

GEAR

B  
A  
G  
S

Wilson



REMOVABLE  
CUSTOMIZATION  
PANEL

WILSON® PUDGE 2.0 BAG ON WHEELS

STOCK NO.	SIZE	MSRP
WTA9721	39" L x 16.5" W x 13" H	\$159.95

- Extra large main compartment fits helmets, gloves, cleats, and a complete set of catcher's gear
- Fits 4 bats comfortably
- Fleece lined valuables pocket and pocket for sunglasses along with other accessories
- Large side pocket for shin guards or other miscellaneous gear
- Removable decoration panel fits onto 18" hoop
- Wheel chassis with 3" clearance
- Telescopic pull handle with zip cover
- Massive #10 zippers on main opening
- Bottom rails provide durability to the back during transportation



REMOVABLE  
CUSTOMIZATION  
PANEL

WILSON® TEAM GEAR BAG

STOCK NO.	SIZE	MSRP
WTA9709	40" L x 14.5" W x 13" H	\$49.95

- Extra large main compartment fits helmets, gloves, cleats, a complete set of catcher's gear, and more
- Separate ventilated compartment for shoes, wet gear or a catcher's helmet
- Removable decoration panel fits onto 18" hoop (minimum)
- #8 zippers on main opening
- Handles on both sides for easy loading







 demarinisports  
demariniFP

 @demarini  
@demariniFP  
@demariniSP

 @demarini  
@demariniFP

 @demarination

---

**BATS THAT CAN BACK IT UP**, apparel, equipment and uniforms with performance and swagger. DeMarini® is relentless in its obsession with player-driven innovation and bold in its product design. This unconventional approach has made all the difference for teams and players who join DeMarini Nation.





TOP  
COLLEGIATE  
PROGRAMS



# BASEBALL BATS

Dedicated to designing bold bats and standout equipment, DeMarini's commitment to player-driven innovation remains unrivaled.

R

# BBCOR

2 5/8" BARREL



CF® ZEN [-3] BALANCED

CF® INSANE [-3] BALANCED

VOODOO® BALANCED [-3]

VOODOO® INSANE® [-3] ENDOLOADED

VOODOO® ONE [-3] BALANCED

NEW



CF® ZEN™ [-3] BALANCED

						MSRP	
30"/27	31"/28	32"/29	33"/30	34"/31	WTDXCBC-18	-3	\$449.95



PARAFLEX™ COMPOSITE:  
22% stronger for more precise weight distribution with massive and mad pop



3FUSION™ HANDLE:  
New streamlined design allows for greater weight control and feel



3FUSION™ END CAP:  
Optimizes bat weight control and performance

NEW



CF® INSANE® [-3] ENDOLOADED

						MSRP	
	31"/28	32"/29	33"/30	34"/31	WTDXCIC-18	-3	\$449.95



PARAFLEX™ COMPOSITE:  
22% stronger for more precise weight distribution with massive and mad pop



3FUSION™ HANDLE:  
New streamlined design allows for greater weight control and feel



3FUSION™ END CAP:  
Optimizes bat weight control and performance

NEW



VOODOO® BALANCED [-3]

					MSRP		
	30"/27	31"/28	32"/29	33"/30	WTDXVBC-18	-3	\$299.95



X14 ALLOY™:  
More precise weight distribution for mad pop and more options - balanced, endloaded and one-piece



3FUSION™ HANDLE:  
New streamlined design allows for greater weight control and feel



3FUSION™ END CAP:  
Optimizes bat weight control and performance

NEW



VOODOO® INSANE® [-3] ENDOLOADED

						MSRP		
	32"/29	32.5"/29.5	33"/30	33.5"/30.5	34"/31	WTDXVIC-18	-3	\$299.95



X14 ALLOY™:  
More precise weight distribution for mad pop and more options - balanced, endloaded and one-piece



3FUSION™ HANDLE:  
New streamlined design allows for greater weight control and feel



3FUSION™ END CAP:  
Optimizes bat weight control and performance



NEW



VOODOO® ONE [-3] BALANCED

						MSRP		
	30"/27	31"/28	32"/29	33"/30	34"/31	WTDXVOC-18	-3	\$249.95



X14 ALLOY™:  
More precise weight distribution for mad pop and more options - balanced, endloaded and one-piece



3FUSION™ END CAP:  
Optimizes bat weight control and performance

[Available for customization at: [DeMariniCustomBats.com](http://DeMariniCustomBats.com) Contact your Territory Manager]





# SENIOR LEAGUE & JUNIOR BIG BARREL

2 3/4" & 2 5/8" BARRELS



CF ZEN [-10] & [-8] BALANCED

VOODOO® [-5] & [-10] BALANCED

VOODOO® ONE [-10] BALANCED

UPRISING™ [-10] JBB



NEW



CF ZEN™ [-10] 2 3/4" [-8] 2 5/8" BALANCED

						MSRP
28"/18	29"/19	30"/20	31"/21	32"/22	WTDXCBBZ-18	-10 \$349.95
	29"/21	30"/22	31"/23	32"/24	WTDXCBBR-18	-8 \$349.95

- PARAFLEX™ COMPOSITE:**  
22% stronger for more precise weight distribution with massive and mad pop
- 3FUSION™ HANDLE:**  
New streamlined design allows for greater weight control and feel
- 3FUSION™ END CAP:**  
Optimizes bat weight control and performance



NEW



VOODOO® [-5] 2 5/8" [-10] 2 3/4" BALANCED

						MSRP
		30"/25	31"/26	32"/27	33"/28	WTDXVB5-18 -5 \$249.95
28"/18	29"/19	30"/20	31"/21	32"/22	WTDXVBZ-18	-10 \$249.95

- X14 ALLOY™:**  
More precise weight distribution for mad pop and more options - balanced, endloaded and one-piece
- 3FUSION™ HANDLE:**  
New streamlined design allows for greater weight control and feel
- 3FUSION™ END CAP:**  
Optimizes sweet spot, sound and feel throughout the barrel

NEW



VOODOO® ONE [-10] BALANCED 2 3/4"

						MSRP
	29"/19	30"/20	31"/21	32"/22	WTDXVOZ-18	-10 \$199.95

- X14 ALLOY™:**  
More precise weight distribution for mad pop and more options - balanced, endloaded and one-piece
- 3FUSION™ END CAP:**  
Optimizes sweet spot, sound and feel throughout the barrel



UPRISING™ [-10] JUNIOR BIG BARREL 2 3/4"

						MSRP
	26"/16	28"/18	29"/19	30"/20	WTDXUPY17	-10 \$89.95

- DX1™ ALLOY:**  
High KSI strength alloy built for performance

Available for customization at [DeMariniCustomBats.com](http://DeMariniCustomBats.com)  
Contact your Territory Manager



# USA BASEBALL



VOODOO® USA [-10] BALANCED

VOODOO® ONE USA [-10] BALANCED

VOODOO® USA [-9] BALANCED

UPRISING™ USA [-9] BALANCED

CF™ USA [-13] TEE BALL

NJ State Approved Co-op #65MCESCPCS

Metuchen/Garden State Apparel

Bid Term: 5/9/18 - 5/8/20

**NEW**



VOODOO® USA [-10] BALANCED 2 5/8" BARREL

						MSRP	
28"/18	29"/19	30"/20	31"/21	32"/22	WTDXUD2-18	-10	\$249.95



**X14 ALLOY™:**  
More precise weight distribution for mad pop and more options - balanced, endloaded and one-piece



**3FUSION™ HANDLE:**  
New streamlined design allows for greater weight control and feel



**3FUSION™ END CAP:**  
Optimizes sweet spot, sound and feel throughout the barrel

MEETS NEW USA BASEBALL BAT STANDARD

**NEW**



VOODOO® ONE USA [-10] BALANCED 2 5/8" BARREL

						MSRP	
28"/18	29"/19	30"/20	31"/21	32"/22	WTDXU02-18	-10	\$199.95



**X14 ALLOY™:**  
More precise weight distribution for mad pop and more options - balanced, endloaded and one-piece



**3FUSION™ END CAP:**  
Optimizes sweet spot, sound and feel throughout the barrel

MEETS NEW USA BASEBALL BAT STANDARD

**NEW**



VOODOO® USA [-9] BALANCED 2 1/2" BARREL

						MSRP		
27"/18	28"/19	29"/20	30"/21	31"/22	32"/23	WTDXUXX-18	-9	\$149.95



**X14 ALLOY™:**  
More precise weight distribution for mad pop and more options - balanced, endloaded and one-piece



**IonD END CAP:**  
Midprofile and lightweight end cap for lower MOI

MEETS NEW USA BASEBALL BAT STANDARD

**NEW**



UPRISING® USA [-9] BALANCED 2 1/2" BARREL

						MSRP		
27"/18	28"/19	29"/20	30"/21	31"/22	32"/23	WTDXUPL18	-9	\$99.95



**DX1™ ALLOY:**  
High KSI strength alloy built for performance



**IonD END CAP:**  
Midprofile and lightweight end cap for lower MOI

MEETS NEW USA BASEBALL BAT STANDARD

**NEW**



CF® USA TEE BALL 2 1/4" BARREL

			MSRP		
	25"/12	26"/13	WTDXUCT18	-13	\$34.95

**TP COMPOSITE HANDLE:**  
Composite handle promotes light flex for more performance

MEETS NEW USA BASEBALL BAT STANDARD

FOR USE IN TEE BALL ONLY



# WOOD COMPOSITE

BBCOR CERTIFIED .50



D110 PRO MAPLE™

D113 PRO MAPLE™

D243 PRO MAPLE™

D271 PRO MAPLE™



## D110 PRO MAPLE™ WOOD COMPOSITE

		MSRP
WTDX110B01831: 31"/28	WTDX110B01832: 32"/29	\$199.95
WTDX110B01833: 33"/30	WTDX110B01834: 34"/31	

SINGLE WALL

- A** APPROVED FOR SHORT SEASON A
- R** APPROVED FOR ROOKIE BALL
- PG** APPROVED FOR PERFECT GAME PLAY



## D113 PRO MAPLE™ WOOD COMPOSITE

		MSRP
WTDX113B61831: 31"/28	WTDX113B61832: 32"/29	\$199.95
WTDX113B61833: 33"/30	WTDX113B61834: 34"/31	

SINGLE WALL

- A** APPROVED FOR SHORT SEASON A
- R** APPROVED FOR ROOKIE BALL
- PG** APPROVED FOR PERFECT GAME PLAY



## D243 PRO MAPLE™ WOOD COMPOSITE

		MSRP
WTDX243BN1831: 31"/28	WTDX243BN1832: 32"/29	\$199.95
WTDX243BN1833: 33"/30	WTDX243BN1834: 34"/31	

SINGLE WALL

- A** APPROVED FOR SHORT SEASON A
- R** APPROVED FOR ROOKIE BALL
- PG** APPROVED FOR PERFECT GAME PLAY



## D271 PRO MAPLE™ WOOD COMPOSITE

		MSRP
WTDX271BW1831: 31"/28	WTDX271BW1832: 32"/29	\$199.95
WTDX271BW1833: 33"/30	WTDX271BW1834: 34"/31	

SINGLE WALL

- A** APPROVED FOR SHORT SEASON A
- R** APPROVED FOR ROOKIE BALL
- PG** APPROVED FOR PERFECT GAME PLAY



# FUNGO



FUNGODELIC™

FUNGO WOOD



FUNGODELIC™ PRO MAPLE WOOD COMPOSITE

		MSRP
35"/23	WTDXFUNDE1835	\$99.95

**CONSTRUCTION:**  
Composite frame for durability

**WOOD BARREL:**  
For traditional Fungo feel

**END LOADED FEEL:**  
With weight in the barrel for best ground ball and fly ball hitting



WOOD FUNGO

		MSRP
35"	WTDXFUNW35	\$99.95

**HITTING:**  
Designed for hitting infield and outfield Fungos

FULL MAPLE CONSTRUCTION



FASTPITCH BATS

TOP COLLEGIATE PROGRAMS



If you want to be the best, you have to keep pushing forward at all times. You can't stop to rest. Because the moment you do, someone's ready to take your place.

Just like the hitters we make them for, our bats strive to improve year after year. Driven by innovation, the 2018 CFX lineup pushes the limits of bat technology to create our lightest swinging, best performing bats to date.

# FASTPITCH BATS

# CFX™ [-8] [-9] [-10]



CFX™ [-8]

CFX™ [-9]

CFX™ INSANE™ [-10]



CFX™ [-8]

				MSRP
33"/25	34"/26	WTDXCF8-18	-8	\$349.95

- PARAFLEX™ COMPOSITE:  
22% stronger for more precise weight distribution with massive and mad pop
- 3FUSION™ END CAP:  
Optimizes sweet spot, sound and feel throughout the barrel



CFX™ [-9]

				MSRP
32"/23	33"/24	34"/25	WTDXCF9-18	-9 \$349.95

- PARAFLEX™ COMPOSITE:  
22% stronger for more precise weight distribution with massive and mad pop
- 3FUSION™ HANDLE:  
New streamlined design allows for greater weight control and feel
- 3FUSION™ END CAP:  
Optimizes sweet spot, sound and feel throughout the barrel



CFX™ INSANE™ [-10]

				MSRP	
31"/21	32"/22	33"/23	34"/24	WTDXCFI-18	-10 \$349.95

- PARAFLEX™ COMPOSITE:  
22% stronger for more precise weight distribution with massive and mad pop
- 3FUSION™ HANDLE:  
New streamlined design allows for greater weight control and feel
- 3FUSION™ END CAP:  
Optimizes sweet spot, sound and feel throughout the barrel

[Available for customization at [DeMariniCustomBats.com](http://DeMariniCustomBats.com) Contact your Territory Manager]



# CFX™ [-10] [-11]



CFX™ [-10] BALANCED

CFX SLAPPER™ [-10] EXTREME BALANCED

CFX™ [-11]

NJ State Approved Co-op #65MCECCPS

Metuchen/Garden State Apparel



**NEW** CFX™ [-10] BALANCED

						MSRP
30"/20	31"/21	32"/22	33"/23	34"/34	WTDXCFP-18	-10 \$349.95

- PARAFLEX™ COMPOSITE:**  
22% stronger for more precise weight distribution with massive and mad pop
- 3FUSION™ HANDLE:**  
New streamlined design allows for greater weight control and feel
- 3FUSION™ END CAP:**  
Optimizes sweet spot, sound and feel throughout the barrel



**NEW** CFX™ SLAPPER™ [-10] EXTREME BALANCED

						MSRP
	31"/21	32"/22	33"/23	34"/24	WTDXCFA-18	-10 \$349.95

- PARAFLEX™ COMPOSITE:**  
22% stronger for more precise weight distribution with massive and mad pop
- 3FUSION™ HANDLE:**  
New streamlined design allows for greater weight control and feel
- 3FUSION™ END CAP:**  
Optimizes sweet spot, sound and feel throughout the barrel



**NEW** CFX™ [-11]

					MSRP
	28"/17	29"/18	30"/19	WTDXCFS-18	-11 \$349.95
	31"/20	32"/21	33"/22		

- PARAFLEX™ COMPOSITE:**  
22% stronger for more precise weight distribution with massive and mad pop
- 3FUSION™ HANDLE:**  
New streamlined design allows for greater weight control and feel
- 3FUSION™ END CAP:**  
Optimizes sweet spot, sound and feel throughout the barrel
- 14" EXTENDED BARREL**

Available for customization at: [DeMariniCustomBats.com](http://DeMariniCustomBats.com) DEMARINI CUSTOMS  
Contact your Territory Manager

Bid Term: 5/9/18 - 5/8/20

# FASTPITCH [-10] [-12] [-13]



VENDETTA™ [-10]

VENDETTA™ [-12]

BUSTOS™ [-13]

UPRISING™ [-12]



VENDETTA™ [-10]

					MSRP
30"/20	31"/21	32"/22	33"/23	WTDXVCP-17	-10 \$199. <sup>95</sup>

- PARADOX™ COMPOSITE BARREL:  
Designed to perform softer, hotter, more responsive
- D-LITE™ HANDLE:  
Eliminates vibration for a smooth feel on every swing
- BIG D™ END CAP:  
Absorbs vibration while keeping swing weight low



VENDETTA™ [-12]

					MSRP	
29"/17	30"/18	31"/19	32"/20	33"/21	WTDXVCF-17	-12 \$199. <sup>95</sup>

- PARADOX™ COMPOSITE BARREL:  
Designed to perform softer, hotter, more responsive
- D-LITE™ HANDLE:  
Eliminates vibration for a smooth feel on every swing
- BIG D™ END CAP:  
Absorbs vibration while keeping swing weight low



BUSTOS™ [-13]

					MSRP
29"/16	30"/17	31"/18	32"/19	WTDXBFP-17	-13 \$119. <sup>95</sup>

- DX1™ ALLOY:  
High KSI strength alloy built for performance
- HALF AND HALF



UPRISING™ [-12]

					MSRP	
28"/16	29"/17	30"/18	31"/19	32"/20	WTDXUPF-17	-12 \$79. <sup>95</sup>

- DX1™ ALLOY:  
High KSI strength alloy built for performance
- HYBRID PERFORMANCE GRIP:  
2 piece grip with tacky feel



SLOWPITCH BATS

# SLOWPITCH BATS

This is where legacy meets innovation. Where insane dedication to performance collides with unparalleled passion for competition.

This is the 2018 DeMarini® Slowpitch lineup. Meet the wrecking crew.

NJ State Approved Co-op #65MCECCPS

Metuchen/Garden State Apparel

Bid Term: 5/9/18 - 5/8/20

ASA



FLIPPER™ AFTERMATH OG

FLIPPER™ AFTERMATH USA

JUGGY™ OVL

MERCY™

DEMARINI CUSTOMS



FLIPPER™ OG

				MSRP
34"/26	34"/27	34"/28	WTDXFLS-17	\$329.95

SINGLE WALL



**DIVERGENCE BARREL:**  
Gapped barrel design creates maximum softness and trampoline effect



**SC4™ ALLOY HANDLE:**  
Stiff, aluminum handle helps give the one piece feel



**13"** 13" BARREL



FLIPPER™ USA

				MSRP	
34"/26	34"/27	34"/28	34"/30	WTDXFLA-17	\$329.95

SINGLE WALL



**DIVERGENCE BARREL:**  
Gapped barrel design creates maximum softness and trampoline effect



**SC4™ ALLOY HANDLE:**  
Stiff, aluminum handle helps give the one piece feel



**12"** 13" BARREL



JUGGY™ OVL

				MSRP
34"/26	34"/27	34"/28	WTDXNT4-17	\$299.95

SINGLE WALL



**2X** STACKED DOUBLE WALL CONSTRUCTION



**TR3 F.L.O. COMPOSITE HANDLE:**  
Composite handle promotes light flex for more performance



**12"** 12" BARREL



MERCY™

			MSRP
34"/25	34"/26	WTDXMSP-17	\$299.95

SINGLE WALL



**4.0NE COMPOSITE BARREL:**  
Barrel designed for maximum compression and explosive performance



**4.0NE COMPOSITE HANDLE**

CLUTCH 2 END CAP

[Available for customization at [DeMariniCustomBats.com](http://DeMariniCustomBats.com) Contact your Territory Manager] DEMARINI CUSTOMS



# USSSA / SSUSA



DINGER SLINGER™ 1.20

NEW BREED™ / GTS™ PLAYER SIGNATURE

JUGGY™ DALE BRUNGHART™ DB44 SIGNATURE

LARRY CARTER SIGNATURE SR SOFTBALL MIDLOAD



**NEW**

## DINGER SLINGER™

				MSRP
34"/26	34"/27	34"/28	WTDXDSU-17	\$329.95

- SC4** SC4™ ALLOY HANDLE:  
Stiff, aluminum handle helps give the one piece feel
- 13"** 13" MULTI-WALL COMPOSITE BARREL



**NEW**

## NEWBREED™ GTS™ SIGNATURE SERIES

				MSRP
34"/26	34"/27	34"/28	WTDXNBU-17	\$299.95

- S ONE** S. ONE COMPOSITE BARREL:  
End Loaded barrel designed for maximum compression and explosive performance
- SC4** SC4™ ALLOY HANDLE:  
Stiff, aluminum handle helps give the one piece feel



**NEW**

## JUGGY™ DB44 DALE BRUNGHART SIGNATURE SERIES

				MSRP	
34"/25	34"/26	34"/27	34"/28	WTDXNTB-17	\$299.95

- D-FUSION 2.0** D-FUSION 2.0 HANDLE:  
Reduces vibration and redirects energy back into barrel
- 2X** STACKED DOUBLE WALL CONSTRUCTION



## LARRY CARTER™ SIGNATURE SR SOFTBALL - MID LOAD

				MSRP		
34"/26	34"/27	34"/28	34"/29	34"/30	WTDXSNM-16	\$219.95

- S ONE** 4. ONE COMPOSITE BARREL:  
Barrel designed for maximum compression and explosive performance

[ Available for customization at [DeMariniCustomBats.com](http://DeMariniCustomBats.com)  
Contact your Territory Manager ]



# ALL ASSOCIATION



STEEL™

ULTIMATE WEAPON™

CORNDOG™

UPRISING™

WINDY CITY MUSHBALL™



STEEL™

				MSRP
34"/26	34"/28	34"/30	WTDXSTL-16	\$229.95

**NEW** CARBURIZED SEAMLESS DRAWN STEEL:  
For increased performance, strength and durability.  
Designed specifically for DeMarini



ULTIMATE WEAPON™

				MSRP
34"/26	34"/28	34"/30	WTDXUWE-17	\$149.95

**NEW** SC4™ ALLOY:  
Strong, thin, one-piece performance aluminum



CORNDOG™ SLOW PITCH WOOD COMPOSITE

			MSRP
34"	WTDXCDS1734		\$149.95

UPDATED PROFILE MATERIALS:  
Improved continuous taper design with Paraflex Composite handle  
and Pro Maple Barrel

90 DAY WARRANTY



UPRISING™ SP

				MSRP
34"/26	34"/28	34"/30	WTDXUPS00	\$99.95

**NEW** DX1™ ALLOY:  
High KSI strength alloy built for performance



WINDY CITY MUSHBALL™ 14" & 16"

				MSRP	
34"/32	34"/34	34"/36	34"/38	WTDXWCS	\$149.95

SINGLE WALL





BATTING GLOVES

# BATTING GLOVES

# SHATTER™ / DIGI CAMO™



SHATTER™



DIGI CAMO™

DEMARINI CUSTOMS

## SHATTER™

			MSRP
WTD6112	MEN'S SIZES	S-2XL	\$44. <sup>99</sup>

- SMOOTH SHEEP SKIN PALM: Smooth premium leather for supreme feel
- 4-WAY STRETCH: Diamond mesh backhand
- PRO GRADE WRIST STRAP: Wicks away moisture
- LEATHER WRAPPED FINGERS: Allows for ultimate comfort



## DIGI CAMO™

			MSRP
WTD6113	MEN'S SIZES	S-2XL	\$34. <sup>99</sup>
WTD6313	YOUTH SIZES	S-L	\$34. <sup>99</sup>

- SMOOTH SHEEP SKIN PALM: Smooth leather for supreme feel
- 4-WAY STRETCH: Ribbed spandex backhand
- PRO GRADE WRIST STRAP: Wicks away moisture
- SILICON OVERLAY BACKHAND: Silicon overlay for added structure



Available for customization. Contact your Territory Manager. DEMARINI CUSTOMS

NJ State Approved Co-op #65MCECCPS

Metuchen/Garden State Apparel

Bid Term: 5/9/18 - 5/8/20





# PHANTOM™ / BAT WEIGHT



PHANTOM™

## PHANTOM™

			MSRP
WTD6111	MEN'S SIZES	S-2XL	\$29.99
WTD6311	YOUTH SIZES	S-L	\$29.99

-  **SMOOTH SHEEP SKIN PALM:** Smooth leather for supreme feel
-  **4-WAY STRETCH:** Diamond mesh backhand
-  **WRIST STRAP:** Wide low profile strap for an unobstructed swing motion



## BAT WEIGHT

		MSRP
WTA6757	16 OZ.	\$8.95



BAT WEIGHT



# BATTING HELMETS



# PARADOX™



PARADOX™ FITTED PRO

## PARADOX™ FITTED PRO BATTING HELMET

	MSRP
WTD5401	\$49. <sup>99</sup>
WTD5421: With Fastpitch Mask	\$69. <sup>99</sup>
XS [6 <sup>5</sup> / <sub>8</sub> -6 <sup>3</sup> / <sub>4</sub> ], S [6 <sup>7</sup> / <sub>8</sub> -7], M [7 <sup>1</sup> / <sub>8</sub> -7 <sup>1</sup> / <sub>4</sub> ], L [7 <sup>3</sup> / <sub>8</sub> -7 <sup>1</sup> / <sub>2</sub> ], XL [7 <sup>5</sup> / <sub>8</sub> -7 <sup>3</sup> / <sub>4</sub> ], 2X [7 <sup>7</sup> / <sub>8</sub> -8]	

- 1 DUAL DENSITY PADDING: Fully wrapped pads, fitted to your specific size for the perfect fit
- 2 PREMIUM RUBBERIZED MATTE FINISH
- 3 STRATEGIC VENTING SYSTEM: Keeps head cool
- 4 LOW PROFILE SHELL: For superior fit



PARADOX™ TWO-TONE

## PARADOX™ TWO-TONE BATTING HELMET



	MSRP
WTD5403TT	\$34. <sup>95</sup>
YH [6 <sup>1</sup> / <sub>2</sub> and Below], S/M [6 <sup>3</sup> / <sub>8</sub> -7 <sup>1</sup> / <sub>8</sub> ], L/XL [7-7 <sup>1</sup> / <sub>8</sub> ]	

- 1 DUAL DENSITY PADDING: Fully wrapped pads sublimated with team colors
- 2 TWO-TONE PREMIUM RUBBERIZED MATTE FINISH
- 3 STRATEGIC VENTING SYSTEM: Keeps head cool
- 4 LOW PROFILE SHELL: For superior fit



PARADOX™

## PARADOX™ BATTING HELMET



	MSRP
WTD5403	\$34. <sup>99</sup>
WTD5423: With Fastpitch Mask	\$44. <sup>99</sup>
YH [6 <sup>1</sup> / <sub>2</sub> and Below], S/M [6 <sup>3</sup> / <sub>8</sub> -7 <sup>1</sup> / <sub>8</sub> ], L/XL [7-7 <sup>1</sup> / <sub>8</sub> ]	

- 1 DUAL DENSITY PADDING: Wrapped ear pads sublimated with team colors
- 2 PREMIUM RUBBERIZED MATTE FINISH
- 3 STRATEGIC VENTING SYSTEM: Keeps head cool
- 4 LOW PROFILE SHELL: For superior fit



# PARADOX™



PARADOX™ PROTÉGÉ™

## PARADOX™ PROTÉGÉ™ BATTING HELMET

	MSRP
WTD5404	\$24.99
WTD5424: With Fastpitch Mask	\$34.99
YH [6½ and Below], S/M [6¾-7¼], L/XL [7-7¾]	

- 1 DUAL DENSITY PADDING: Covered in fabric sublimated with team colors
- 2 GLOSSY FINISH
- 3 STRATEGIC VENTING SYSTEM: Keeps head cool
- 4 LOW PROFILE SHELL: For superior fit



## PARADOX™ BASEBALL FACEMASKS

	MSRP
WTD319600: Baseball Facemask Small	\$12.99
WTD319700: Baseball Facemask Large	\$12.99

GREAT SIGHT LINES: Engineered to provide biggest and best sight lines.

EASY INSTALL: Only four total screws (hardware included)

Small Mask fits DeMarini helmets in the following sizes (XS, S, M) and (S/M, YH)

Large Mask fits DeMarini helmets (L, XL, 2X) and (L/XL)

## PARADOX™ FASTPITCH FACEMASKS

	MSRP
WTD318600: Fastpitch Facemask Small	\$12.99
WTD318700: Fastpitch Facemask Large	\$12.99

GREAT SIGHT LINES: Engineered to provide biggest and best sight lines.

EASY INSTALL: Only four total screws (hardware included)

Small Mask fits DeMarini helmets in the following sizes (XS, S, M) and (S/M, YH)

Large Mask fits DeMarini helmets (L, XL, 2X) and (L/XL)



PARADOX™ FACEMASKS

## PARADOX™ CHIN STRAP

	MSRP
WTD385900	\$3.99

FULLY ADJUSTABLE: For custom fit

Fits all DeMarini Paradox™ Helmets



PARADOX™ CHIN STRAP



SLOWPITCH BALLS



# SLOWPITCH BALLS



# SLOWPITCH BALLS

## ASA® SERIES

### LIGHTNING™

STOCK NO.  
WTALL 11YA-B: 11"

MSRP  
\$68.99

COVER  
LEATHER OPTIC YELLOW\*

STITCH	COR	COMP.
RED	.44	375 LBS.

STOCK NO.  
WTALS 11YA-B: 11"

MSRP  
\$56.99

COVER  
SYNTHETIC LEATHER OPTIC YELLOW\*



ASA® REQUIREMENTS:  
.44 COR; 300 LBS. MAX. COMPRESSION

### STONE™

STOCK NO.  
WTASTONEL12YAB: 12"

MSRP  
\$68.99

COVER  
LEATHER OPTIC YELLOW\*

STITCH	COR	COMP.
RED	.52	300 LBS.

STOCK NO.  
WTASTONES12YAB: 12"  
WTASTONES11YAB: 11"

MSRP  
\$56.99

COVER  
SYNTHETIC LEATHER OPTIC YELLOW\*



ASA® REQUIREMENTS:  
.52 COR; 300 LBS. MAX. COMPRESSION

AVAILABLE IN RETAIL PACK

WTASTONEL12YAT

LIST PRICE  
\$75.99

## USSSA® SERIES

### WOMEN'S CLASSIC W SERIES

STOCK NO.  
WTALL 11YUW-B: 11"

MSRP  
\$68.99

COVER  
LEATHER OPTIC YELLOW\*

STITCH	COR	COMP.
BLUE	.44	400 LBS.

STOCK NO.  
WTALS 11YUW-B: 11"

MSRP  
\$56.99

COVER  
SYNTH. LEATHER OPTIC YELLOW\*

USSSA® Requirements  
Women's Classic W: .44 COR;  
400 lbs. max. compression



### MEN'S CLASSIC M SERIES

STOCK NO.  
WTALL 12YUM-B: 12"

MSRP  
\$68.99

COVER  
LEATHER OPTIC YELLOW\*

STITCH	COR	COMP.
BLUE	.40	325 LBS.

STOCK NO.  
WTALS 12YUM-B: 12"

MSRP  
\$56.99

COVER  
SYNTH. LEATHER OPTIC YELLOW\*

USSSA® Requirements  
Men's Classic M: .40 COR;  
325 lbs. max. compression



AVAILABLE IN RETAIL PACK

WTALL 12YUM-T

LIST PRICE  
\$75.38

### MEN'S CLASSIC Y SERIES

STOCK NO.  
WTALL 12YUC-B: 12"

MSRP  
\$68.99

COVER  
LEATHER OPTIC YELLOW\*

STITCH	COR	COMP.
BLUE	.52	300 LBS.

STOCK NO.  
WTALS 12YUC-B: 12"

MSRP  
\$56.99

COVER  
SYNTH. LEATHER OPTIC YELLOW\*

USSSA® Requirements:  
.52 COR;  
300 lbs. max. compression



## NSA® SERIES

STOCK NO.  
WTA9071BNSA: 12"

MSRP  
\$68.99

COVER  
LEATHER OPTIC YELLOW\*

STITCH	COR	COMP.
BLACK	.52	275 LBS.

STOCK NO.  
WTA9171BNSA: 12"

MSRP  
\$56.99

COVER  
SYNTH. LEATHER OPTIC YELLOW\*

NSA® Requirements  
.52 COR;  
275 lbs. max compression



STOCK NO.  
WTA9371BNSA: 11"

MSRP  
\$56.99

COVER  
SYNTH. LEATHER OPTIC YELLOW\*

STITCH	COR	COMP.
BLACK	.52	275 LBS.

NSA® Requirements  
.52 COR;  
275 lbs. max compression





GEAR BAGS



# GEAR BAGS



SPECIAL OPS™ BACKPACK

		MSRP
WTD9408	12" L x 14.5" W x 21.5" H	\$109. <sup>95</sup>

- FITS: Helmet, glove and gear
- BAT SLEEVES: Holds up to 6 bats (4 Neoprene)
- LARGE FLEECE POCKET: Holds up to 6 softballs
- BREATHABLE MAIN COMPARTMENT: To store shoes or wet gear
- REMOVABLE DECORATION PANEL: Fits onto 18" Hoop
- INSIDE FLEECE POCKET: Easy access to valuables
- INTERIOR SHELF TO: Separate players glove from other gear
- MULTIPLE INNER POCKETS
- PADDED: Shoulder straps and back paneling
- DURABLE: J style fence hook



VOODOO™ REBIRTH BACKPACK

		MSRP
WTD9105	13" L X 12" W X 20.5" H	\$59. <sup>95</sup>

- LARGE MAIN COMPARTMENT Fits helmet, glove and gear
- MOLDED BARREL LOCK NEOPRENE BAT SLEEVES: Holds up to 2 bats
- CELL PHONE POCKET: Fleece Lined
- SHOES: Vented compartment
- REMOVABLE DECORATION PANEL: Fits onto 12" Hoop
- DURABLE: J style fence hook
- COMPOSITE TREATED: Waterproof base material
- PADDED: shoulder straps and back paneling







REMOVABLE CUSTOMIZATION PANEL



MOMENTUM™ BACKPACK

		MSRP
WT09407	12.5" L X 8.5" W X 20.5" H	\$49.95

LARGE MAIN COMPARTMENT: Fits helmet, Glove and gear

MESH BAT SLEEVES: Holds up to 2 bats (doubles as water bottle holder)

CELL PHONE POCKET: Fleece Lined

SHOES: Vented Compartment

REMOVABLE DECORATION PANEL: Fits onto 12" Hoop

INTEGRATED FENCE HOOK

FOAM PADDED: Shoulder straps and back paneling



UPRISING™ BACKPACK

		MSRP
WT09104	12" L x 7" W x 17.5" H	\$29.95

MAIN COMPARTMENT: Fits helmet, cleats and glove

MESH BAT SLEEVES: Holds up to 2 bats

INTEGRATED FENCE HOOK

COMPOSITE TREATED: Waterproof base material



REMOVABLE CUSTOMIZATION PANEL



BULLPEN™ DUFFEL

		MSRP
WT09302	29" L X 14" W X 10" H	\$59.95

LARGE MAIN COMPARTMENT: Fits helmet, glove and gear

BAT SLEEVES: Holds up to 2 bats

CELL PHONE POCKET: Fleece Lined

SHOES: Vented Compartment

REMOVABLE DECORATION PANEL: Fits onto 18" Hoop

HEAVY DUTY: Swivel Speed Clips

COMPOSITE TREATED: Waterproof base material

PADDED: Shoulder Strap





NEW



REMOVABLE CUSTOMIZATION PANEL

SPECIAL OPS™ WHEELED BAG

		MSRP
WTD9409	38.5" L X 15" W X 12" H	\$199.95

- ARMORED BAT COMPARTMENT: 4 individual padded sleeves holds up to 4 bats
- REMOVABLE DECORATION PANEL: Fits onto 18" Hoop
- REMOVABLE: Convertible neoprene straps
- SHOE COMPARTMENT: Breathable and washable
- CELL PHONE POCKET: Fleece Lined
- NEW INLINE WHEELS
- HARD BODY CONSTRUCTION: Protects bag outside and gear inside
- TELESCOPING PULL HANDLE
- PROTECTIVE, ADJUSTABLE COMPARTMENTS: For all gear
- HIDEAWAY FENCE CLAWS



REMOVABLE CUSTOMIZATION PANEL



GRIND™ WHEELED BAG

		MSRP
WTD9202	38" L X 13.5" W X 13.5" H	\$129.95

- LARGE MAIN COMPARTMENT: Fits helmet, glove, and cleats and complete set of catchers gear
- INDIVIDUALLY PADDED BAT SLEEVES: Holds up to 4 bats
- VENTILATED: Shoe compartment
- REMOVABLE DECORATION PANEL: Fits onto 18" Hoop
- WHEEL CHASSIS: 3" clearance
- MASSIVE #10 ZIPPERS ON MAIN OPENING
- BOTTOM RAILS: Provide durability to the back during transportation
- 2 INTEGRATED FENCE HOOKS
- INSIDE VALUABLES POCKETS



NEW



REMOVABLE CUSTOMIZATION PANEL

MOMENTUM™ WHEELED BAG

		MSRP
WTD9406	36" L X 11" W X 10.5" H	\$79.95

- LARGE MAIN COMPARTMENT: Fits helmet, glove and gear
- BAT SLEEVES: Holds up to 4 bats
- CELL PHONE POCKET: Fleece Lined
- REMOVABLE DECORATION PANEL: Fits onto 18" Hoop
- RUGGED WHEELS
- INTERIOR SHELF: To separate players glove or cleats from other gear
- MASSIVE #10 ZIPPERS ON MAIN OPENING
- DURABLE: J style fence hook
- INSIDE VALUABLES POCKETS





---

**LOUISVILLE SLUGGER® BALL PLAYERS** get the best of nearly 130-plus years of innovation in bats, gloves and gear. Every piece of Louisville Slugger equipment is designed and crafted to help them step to the plate with confidence, field the ball with ease and circle the bases with passion – and ultimately, leave their mark on the game.





Powerized

MLB MAPLE C243  
PRIME  
LOUISVILLE SLUGGER

MLB BIRCH A310  
PRIME  
LOUISVILLE SLUGGER

MLB MAPLE 2P13  
PRIME  
LOUISVILLE SLUGGER

MLB MAPLE 0331  
PRIME  
LOUISVILLE SLUGGER

MLB MAPLE C  
PRIME  
LOUISVILLE SLI





TOP COLLEGIATE PROGRAMS



Louisville Slugger,® a name associated with only the best bats in baseball, puts unparalleled performance in the hands of the nation's top players. Through our continued dedication and innovation, we have engineered a lineup of baseball bats designed to help each hitter own the plate.

# BATS

## BASEBALL



# BBCOR

## 2 5/8" BARREL

BBCOR CERTIFIED .50

### LS BBCOR SWING WEIGHT PROFILE

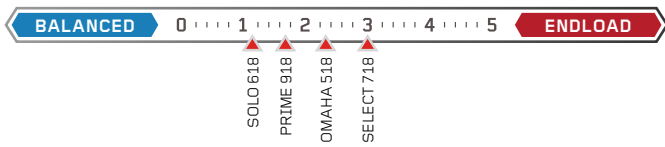

NEW



### PRIME® 918 [-3] 2 5/8"

					MSRP	
31"/28	32"/29	33"/30	34"/31	WTLBBP918B3	-3	\$449. <sup>95</sup>

- 100% Composite – with our proprietary MicroForm™ barrel design for a lighter swing weight and maximum pop
- Patented TRU3™ construction that reduces vibration and provides unmatched feel on contact
- **NEW** RTX™ end cap design allows for a longer barrel shape
- Balanced swing weight score: 1.7
- **NEW** custom Lizard Skin™ premium performance grip
- 31/32" tapered handle

NEW



### SELECT™ 718 [-3] 2 5/8"

					MSRP	
31"/28	32"/29	33"/30	34"/31	WTLBBS718B3	-3	\$349. <sup>95</sup>

- Hybrid Construction – with ST 7U1+ alloy barrel and composite handle for maximum durability and power on contact
- **NEW** Speed Ballistic Composite End Cap (SBC) – for increased swing speed and control
- Patented TRU3™ construction that reduces vibration and provides unmatched feel on contact
- Slight Endload swing weight score: 3.0
- **NEW** custom Lizard Skin™ premium performance grip
- 31/32" tapered handle

NEW



### SOLO™ 618 [-3] 2 5/8"

					MSRP			
29"/26	30"/27	31"/28	32"/29	33"/30	34"/31	WTLBBS618B3	-3	\$299. <sup>95</sup>

- 1pc SL Hyper alloy construction for a stiffer feel and maximum energy transfer on contact
- **NEW** Speed Ballistic Composite End Cap (SBC) – for the absolute lowest MOI & fastest swing speed in our BBCOR line
- Most balanced swing weight score: 1.1
- **NEW** Vibration dampening handle design reduces negative vibration on mis-hits
- **NEW** custom Lizard Skin™ premium performance grip
- 31/32" tapered handle

NEW



### OMAHA™ 518 [-3] 2 5/8"

					MSRP			
29"/26	30"/27	31"/28	32"/29	33"/30	34"/31	WTLBB0518B3	-3	\$199. <sup>95</sup>

- 1pc ST 7U1+ alloy construction that delivers a huge sweet spot and stiffer feel on contact
- **NEW** 6-Star™ premium end cap design
- Mid-balanced swing weight score: 2.3
- **NEW** Vibration dampening handle design reduces negative vibration on mis-hits
- **NEW** custom Lizard Skin™ premium performance grip
- 31/32" tapered handle with injection molded knob

NEW



### VAPOR [-3] 2 5/8"

					MSRP		
30"/27	31"/28	32"/29	33"/30	34"/31	WTLBBVA18B3	-3	\$99. <sup>95</sup>

- 1pc 7-Series alloy for maximum durability and performance at an unbelievable value
- Durable synthetic leather grip
- 31/32" standard handle



# SENIOR LEAGUE



SL-PRIME® 918



SL-SOLO™ 618



SL-CATALYST®



PRIME® 918 [-10] [-8] 2<sup>3</sup>/<sub>4</sub>

							MSRP	
27"/17	28"/18	29"/19	30"/20	31"/21	32"/22	WTLSLP918X10	-10	\$349.95
		29"/21	30"/22	31"/23	32"/24	WTLSLP918X8	-8	\$349.95

- 100% Composite – with our proprietary MicroForm™ barrel design for a lighter swing weight and maximum pop
- Patented TRU3™ construction that reduces vibration and provides unmatched feel on contact
- **NEW** RTX™ end cap design allows for a huge barrel shape
- Balanced swing weight feel
- **NEW** custom Lizard Skin™ premium performance grip
- 31/32" tapered handle



SOLO™ 618 [-10] 2<sup>3</sup>/<sub>4</sub>

							MSRP	
28"/18	29"/19	30"/20	31"/21	32"/22	WTLSLS618X10	-10	\$299.95	

- 1pc SL Hyper alloy construction for a stiffer feel and maximum energy transfer on contact
- **NEW** Speed Ballistic Composite End Cap (SBC) – for the absolute lowest MOI & fastest swing speed in our BBCOR line
- The most balanced swing weight in Slugger's SL line of drop (-10) bat models
- **NEW** custom Lizard Skin™ premium performance grip
- 31/32" tapered handle



CATALYST® [-12] 2<sup>3</sup>/<sub>4</sub>

							MSRP	
27"/15	28"/16	29"/17	30"/18	31"/19	WTLSLCT18X12	-12	\$199.95	

- 100% Ultra-light C1C composite
- 1pc construction for quicker bat speed and maximum control
- Great option for younger players or players looking to maximize swing speed
- Durable synthetic leather grip

# SENIOR LEAGUE



SL- OMAHA® 518

SL- JBB OMAHA® 518



NEW OMAHA® 518 [-10] 2¾ [-5] 2⅝

						MSRP	
26"/16	27"/17	28"/18	29"/19	WTLSL0518X10	-10	2¾	\$179. <sup>95</sup>
	30"/20	31"/21	32"/22				
	30"/25	31"/26	32"/27	WTLSL0518B5	-5	2⅝	\$179. <sup>95</sup>

- 1pc ST 7U1+ alloy construction that delivers a huge sweet spot and stiffer feel on contact
- **NEW** longer barrel for maximum plate coverage
- **NEW** 6-Star™ end cap design
- **NEW** custom Lizard Skin™ premium performance grip
- 7/8" tapered handle



NEW OMAHA® 518 [-10] 2¾ JUNIOR BIG BARREL

						MSRP	
	25"/15	26"/16	27"/17	28"/18	WTLSL0518J10	-10	\$99. <sup>95</sup>

- **NEW** 2¾" barrel design for larger sweet spot
- 1 piece - Performance Alloy
- **NEW** 6-Star™ end cap design
- Durable synthetic leather grip
- 7/8" handle



**CHRISTIAN YELICH**  
Miami Marlins, OF  
MAPLE M356

WOOD BATS

The official bat of MLB,® Louisville Slugger® is second to none. Each bat is the product of 130 years of craftsmanship and an unrivaled love of America's Game. Driven by a rich tradition of innovating in wood, we continue to partner with the top players to craft a better bat. These insights help us develop the best wood with the hardest finish that exceed expectations inside the batter's box.

# BATS

## WOOD

# THE ALL NEW 2018 MLB PRIME LINE UP

MLB Prime bats are made exclusively with MLB Grade wood. The Ink Dot is the mark of the highest quality wood. EXOARMOR finish makes it 2X harder. Harder means farther. And that's the truth.



**JOEY VOTTO**  
Cincinnati Reds, OF  
ASH S318

## #THEHARDTRUTH

EXOARMOR®



THE OFFICIAL BAT OF  
MAJOR LEAGUE BASEBALL



# PRIME MAPLE



C271° MAPLE (AMERICA)

C271° MAPLE (HIGH ROLLER)

C271° MAPLE (MINER)

C243° MAPLE (CHERRY)

**NEW**



## C271° MAPLE (AMERICA)

				MSRP
32"	33"	34"	WTLWPM271A17	\$139. <sup>95</sup>

**WOOD:** MLB® Maple  
**FINISH:** Split-Natural/Royal  
**TURNING MODEL:** C271  
**SWING WEIGHT:** [1] Most Balanced  
**TOP COAT:** Exo Armor™ Premium Hardcoat  
**INK DOT:** Yes  
**BONE RUBBED:** Yes  
**CUPPED:** Yes

**NEW**



## C271° MAPLE (HIGH ROLLER)

				MSRP
32"	33"	34"	WTLWPM271B17	\$139. <sup>95</sup>

**WOOD:** MLB® Maple  
**FINISH:** Fade-Distressed Blame/Flame  
**TURNING MODEL:** C271  
**SWING WEIGHT:** [1] Most Balanced  
**TOP COAT:** Exo Armor™ Premium Hardcoat  
**INK DOT:** Yes  
**BONE RUBBED:** Yes  
**CUPPED:** Yes

**NEW**



## C271° MAPLE (MINER)

				MSRP
32"	33"	34"	WTLWPM271C17	\$139. <sup>95</sup>

**WOOD:** MLB® Maple  
**FINISH:** Fade-Black/Speck Grey  
**TURNING MODEL:** C271  
**SWING WEIGHT:** [1] Most Balanced  
**TOP COAT:** Exo Armor™ Premium Hardcoat  
**INK DOT:** Yes  
**BONE RUBBED:** Yes  
**CUPPED:** Yes

**NEW**



## C243° MAPLE (CHERRY)

				MSRP
32"	33"	34"	WTLWPM243A17	\$139. <sup>95</sup>

**WOOD:** MLB® Maple  
**FINISH:** Vintage Red  
**TURNING MODEL:** C243  
**SWING WEIGHT:** [4] Slight Endload  
**TOP COAT:** Exo Armor™ Premium Hardcoat  
**INK DOT:** Yes  
**BONE RUBBED:** Yes  
**CUPPED:** Yes

# PRIME MAPLE, ASH & BIRCH



JP12™ MAPLE [Holograph]

C271° ASH [BLACK COMET]

AJ10™ BIRCH [NEON WOLF]

C271° MAPLE [BLACK HIGH GLOSS]



JP12™ MAPLE [HOLOGRAPH]

				MSRP
32"	33"	34"	WTLWPMJP12A17	\$139.95

**WOOD:** MLB® Maple  
**FINISH:** Natural  
**TURNING MODEL:** JP12 [Joe Panik]  
**SWING WEIGHT:** [1] Most Balanced  
**TOP COAT:** Exo Armor™ Premium Hardcoat  
**INK DOT:** Yes  
**BONE RUBBED:** Yes  
**CUPPED:** Yes



C271° ASH [BLACK COMET]

				MSRP
32"	33"	34"	WTLWPA271A17	\$139.95

**WOOD:** MLB® Ash  
**FINISH:** Fade-Black/Flame  
**TURNING MODEL:** C271  
**SWING WEIGHT:** [1] Most Balanced  
**TOP COAT:** Exo Armor™ Premium Hardcoat  
**BONE RUBBED:** Yes  
**CUPPED:** Yes



AJ10™ BIRCH [NEON WOLF]

				MSRP
32"	33"	34"	WTLWPBAJ10A17	\$139.95

**WOOD:** MLB® Birch  
**FINISH:** Fade-Stealth Grey/Black  
**TURNING MODEL:** AJ10  
**SWING WEIGHT:** [4] Slight Endload  
**TOP COAT:** Exo Armor™ Premium Hardcoat  
**INK DOT:** Yes  
**BONE RUBBED:** Yes  
**CUPPED:** Yes



C271° MAPLE [BLACK HIGH GLOSS]

				MSRP
32"	33"	34"	WTLWPM271A16	\$139.95

**WOOD:** MLB® Maple  
**FINISH:** Black High Gloss  
**TURNING MODEL:** C271  
**SWING WEIGHT:** [1] Most Balanced  
**TOP COAT:** Exo Armor™ Premium Hardcoat  
**INK DOT:** Yes  
**BONE RUBBED:** Yes  
**CUPPED:** Yes



# PRIME MAPLE



EL3-I13<sup>®</sup> MAPLE [FADE DEEP FLAME TO BLACK]

EL3-I13<sup>®</sup> MAPLE [HICKORY KNG GOLD]

C243<sup>®</sup> MAPLE [SPLIT-BLACK HIGH GLOSS/NATURAL]

CG3-M110<sup>®</sup> MAPLE [CURTIS GRANDERSON PLAYER MODEL]



EL3-I13<sup>®</sup> MAPLE [FADE DEEP FLAME TO BLACK]

				MSRP
32"	33"	34"	WTLWPM13A16	\$139. <sup>95</sup>

**WOOD:** MLB<sup>®</sup> Maple  
**FINISH:** Split-Deep Flame/Black High Gloss  
**TURNING MODEL:** EL3-I13 [E. Longoria]  
**SWING WEIGHT:** [4] Slight Endload

**TOP COAT:** Exo Armor™ Premium Hardcoat  
**INK DOT:** Yes  
**BONE RUBBED:** Yes  
**CUPPED:** Yes



EL3-I13<sup>®</sup> MAPLE [HICKORY KNG GOLD]

				MSRP
32"	33"	34"	WTLWPM13B16	\$139. <sup>95</sup>

**WOOD:** MLB<sup>®</sup> Maple  
**FINISH:** Hickory with KNG Gold  
**TURNING MODEL:** EL3-I13 [E. Longoria]  
**SWING WEIGHT:** [4] Slight Endload

**TOP COAT:** Exo Armor™ Premium Hardcoat  
**INK DOT:** Yes  
**BONE RUBBED:** Yes  
**CUPPED:** Yes



C243<sup>®</sup> MAPLE [SPLIT-BLACK HIGH GLOSS/NATURAL]

				MSRP
32"	33"	34"	WTLWPM243B16	\$139. <sup>95</sup>

**WOOD:** MLB<sup>®</sup> Maple  
**FINISH:** Split-Black High Gloss/Natural  
**TURNING MODEL:** C243  
**SWING WEIGHT:** [4] Slight Endload

**TOP COAT:** Exo Armor™ Premium Hardcoat  
**INK DOT:** Yes  
**BONE RUBBED:** Yes  
**CUPPED:** Yes



CG3-M110<sup>®</sup> MAPLE [CURTIS GRANDERSON PLAYER MODEL]

				MSRP
32"	33"	34"	WTLWPM110GM6	\$139. <sup>95</sup>

**WOOD:** MLB<sup>®</sup> Maple  
**FINISH:** Black Matte  
**TURNING MODEL:** CG3-M110 [C. Granderson]  
**SWING WEIGHT:** [1] Most Balanced

**TOP COAT:** Exo Armor™ Premium Hardcoat  
**INK DOT:** Yes  
**BONE RUBBED:** Yes  
**CUPPED:** Yes

# PRIME MAPLE, ASH & BIRCH



AJ10™ MAPLE [FLAME WITH ORANGE]

DDBP4 MAPLE [TRX RED]

EL3-113° ASH [EVAN LONGORIA PLAYER MODEL]

C271° BIRCH [HORNSBY]



AJ10™ MAPLE [FLAME WITH ORANGE]

				MSRP
32"	33"	34"	WTLWPMJA1B16	\$139.95

**WOOD:** MLB® Maple  
**FINISH:** Flame Tempered/Orange  
**TURNING MODEL:** AJ10 [A. Jones]  
**SWING WEIGHT:** [4] Slight Endload  
**TOP COAT:** Exo Armor™ Premium Hardcoat  
**INK DOT:** Yes  
**BONE RUBBED:** Yes  
**CUPPED:** Yes



DDBP4 MAPLE [TRX RED]

				MSRP
32"	33"	34"	WTLWPMBP4B16	\$139.95

**WOOD:** MLB® Maple  
**FINISH:** TRX Red  
**TURNING MODEL:** DDBP4 [B. Phillips]  
**SWING WEIGHT:** [1] Most Balanced  
**TOP COAT:** Exo Armor™ Premium Hardcoat  
**INK DOT:** Yes  
**BONE RUBBED:** Yes  
**CUPPED:** Yes



EL3-113° ASH [EVAN LONGORIA PLAYER MODEL]

				MSRP
32"	33"	34"	WTLWPAI13GM6	\$139.95

**WOOD:** MLB® Ash  
**FINISH:** Flame Tempered Filler Natural with High Gloss Clear  
**TURNING MODEL:** EL3-113 [E. Longoria]  
**SWING WEIGHT:** [4] Slight Endload  
**TOP COAT:** Exo Armor™ Premium Hardcoat  
**INK DOT:** Yes  
**BONE RUBBED:** Yes  
**CUPPED:** Yes



C271° BIRCH [HORNSBY]

				MSRP
32"	33"	34"	WTLWPB271A16	\$139.95

**WOOD:** MLB® Birch  
**FINISH:** Hornsby High Gloss  
**TURNING MODEL:** C271  
**SWING WEIGHT:** [1] Most Balanced  
**TOP COAT:** Exo Armor™ Premium Hardcoat  
**INK DOT:** Yes  
**BONE RUBBED:** Yes  
**CUPPED:** Yes



# SELECT



C271° MAPLE [GREY STAIN]

C271° MAPLE [BLACK]

I13° MAPLE [NATURAL]



**NEW**

## C271° MAPLE [GREY STAIN]

					MSRP	
	31"	32"	33"	34"	WTLW7M271A17	\$99. <sup>95</sup>
BK LZ SKIN	31"	32"	33"	34"	WTLW7M271A17+G	\$109. <sup>95</sup>

**WOOD:** Series 7 Maple  
**FINISH:** Grey Stain  
**TURNING MODEL:** C271  
**SWING WEIGHT:** [1] Most Balanced

**TOP COAT:** HD High Gloss  
**BONE RUBBED:** Yes  
**CUPPED:** Yes



**NEW**

## C271° MAPLE [BLACK]

					MSRP	
	32"	33"	34"		WTLW7M271B17	\$99. <sup>95</sup>

**WOOD:** Series 7 Maple  
**FINISH:** Black  
**TURNING MODEL:** C271  
**SWING WEIGHT:** [1] Most Balanced

**TOP COAT:** HD High Gloss  
**BONE RUBBED:** Yes  
**CUPPED:** Yes



**NEW**

## I13° MAPLE [NATURAL]

					MSRP	
	32"	33"	34"		WTLW7M113A17	\$99. <sup>95</sup>
WILD FIRE LZ SKIN	32"	33"	34"		WTLW7M113A17+G	\$109. <sup>95</sup>

**WOOD:** Series 7 Maple  
**FINISH:** Natural  
**TURNING MODEL:** I13  
**SWING WEIGHT:** [4] Slight EndLoad

**TOP COAT:** HD High Gloss  
**BONE RUBBED:** Yes  
**CUPPED:** Yes

# SELECT



MIXED MAPLE [FADE-BLACK/NATURAL]

MIXED ASH [FADE-FLAME/BLACK]

MIXED BIRCH [SPLIT-GREY/HORNSBY]



## MIXED MAPLE [FADE-BLACK/NATURAL]

				MSRP	
	32"	33"	34"	WTLW7MMIXA17	\$99. <sup>95</sup>
PHANTOM LZ SKIN	32"	33"	34"	WTLW7MMIXA17+G	\$109. <sup>95</sup>

**WOOD:** Series 7 Maple  
**FINISH:** Fade-Black/Natural  
**TURNING MODEL:** MIXED

**TOP COAT:** HD High Gloss  
**BONE RUBBED:** Yes  
**CUPPED:** Yes



## MIXED ASH [FADE-FLAME/BLACK]

				MSRP	
	32"	33"	34"	WTLW7AMIXA17	\$99. <sup>95</sup>

**WOOD:** Series 7 Ash  
**FINISH:** Fade-Flame/Black  
**TURNING MODEL:** MIXED

**TOP COAT:** HD High Gloss  
**BONE RUBBED:** Yes  
**CUPPED:** Yes



## MIXED BIRCH [SPLIT-GREY/HORNSBY]

				MSRP	
	32"	33"	34"	WTLW7BMIXA17	\$99. <sup>95</sup>

**WOOD:** Series 7 Birch  
**FINISH:** Split-Grey/Hornsby  
**TURNING MODEL:** MIXED

**TOP COAT:** HD High Gloss  
**BONE RUBBED:** Yes  
**CUPPED:** Yes



# LEGACY ASH



M110° ASH [SPLIT-UNFINISHED/FLAME]

C271° ASH [NATURAL]

C243° ASH [MATTE BLACK]



M110° ASH [SPLIT-UNFINISHED/FLAME]

					MSRP
32"	33"	34"	WTLW5A110A16		\$49. <sup>95</sup>

**WOOD:** Series 5 Ash  
**FINISH:** Split-Unfinished/Flame  
**TURNING MODEL:** M110  
**SWING WEIGHT:** [1] Most Balanced

**TOP COAT:** Unfinished  
**BONE RUBBED:** No  
**CUPPED:** Yes



C271° ASH [NATURAL]

					MSRP
32"	33"	34"	WTLW5A271A16		\$49. <sup>95</sup>

**WOOD:** Series 5 Ash  
**FINISH:** Natural  
**TURNING MODEL:** C271  
**SWING WEIGHT:** [1] Most Balanced

**TOP COAT:** Regular Gloss  
**BONE RUBBED:** No  
**CUPPED:** Yes



C243° ASH [MATTE BLACK]

					MSRP
32"	33"	34"	WTLW5A243A16		\$49. <sup>95</sup>

**WOOD:** Series 5 Ash  
**FINISH:** Matte Black  
**TURNING MODEL:** C243  
**SWING WEIGHT:** [4] Slight EndLoad

**TOP COAT:** Regular Matte  
**BONE RUBBED:** No  
**CUPPED:** Yes

# LEGACY LTE ASH



C271° LTE ASH [SPLIT-UNFINISHED/FLAME]

C243° LTE ASH [HORNSBY]

C271° LTE ASH [BLACK]

T141° LTE ASH [SPLIT-BLACK/NATURAL]



C271° LTE ASH [SPLIT-UNFINISHED/FLAME]

				MSRP
32"	33"	34"	WTLW5A271B16	\$49.95

**WOOD:** Series 5 LTE Ash [guaranteed -3oz]  
**FINISH:** Split-Unfinished/Flame  
**TURNING MODEL:** C271  
**SWING WEIGHT:** [1] Most Balanced

**TOP COAT:** Unfinished  
**BONE RUBBED:** No  
**CUPPED:** Yes



C243° LTE ASH [HORNSBY]

				MSRP
32"	33"	34"	WTLW5A243B16	\$49.95

**WOOD:** Series 5 LTE Ash [guaranteed -3oz]  
**FINISH:** Hornsby  
**TURNING MODEL:** C243  
**SWING WEIGHT:** [4] Slight EndLoad

**TOP COAT:** Regular Gloss  
**BONE RUBBED:** No  
**CUPPED:** Yes



C271° LTE ASH [BLACK]

				MSRP	
29"	30"	31"	32"	WTLW5A271C16	\$49.95

**WOOD:** Series 5 LTE Ash [guaranteed -5oz]  
**FINISH:** Black  
**TURNING MODEL:** C271  
**SWING WEIGHT:** [1] Most Balanced

**TOP COAT:** Regular Gloss  
**BONE RUBBED:** No  
**CUPPED:** Yes



T141° LTE ASH [SPLIT-BLACK/NATURAL]

				MSRP
30"	31"	32"	WTLW5A141A16	\$49.95

**WOOD:** Series 5 LTE Ash [guaranteed -5oz]  
**FINISH:** Split-Black/Natural  
**TURNING MODEL:** T141  
**SWING WEIGHT:** [1] Most Balanced

**TOP COAT:** Regular Gloss  
**BONE RUBBED:** No  
**CUPPED:** Yes



# GENUINE MAPLE



M110° MAPLE [SPLIT-NATURAL/PINK]

C271° MAPLE [BLACK]

I13° MAPLE [SPLIT-BLACK/NATURAL]



**NEW**

## M110° MAPLE [SPLIT-NATURAL/PINK]

				MSRP	
32"	33"	34"	WTLW3M110A17	\$49. <sup>95</sup>	

**WOOD:** Series 3 Maple  
**FINISH:** Split-Natural/Pink  
**TURNING MODEL:** M110  
**SWING WEIGHT:** [1] Most Balanced

**TOP COAT:** Regular Finish  
**BONE RUBBED:** No  
**CUPPED:** Yes



## C271° MAPLE [BLACK]

					MSRP	
30"	31"	32"	33"	34"	WTLW3M271A16	\$49. <sup>95</sup>

**WOOD:** Series 3 Maple  
**FINISH:** Black  
**TURNING MODEL:** C271  
**SWING WEIGHT:** [1] Most Balanced

**TOP COAT:** Regular Finish  
**BONE RUBBED:** No  
**CUPPED:** Yes



## I13° MAPLE [SPLIT: BLACK/NATURAL]

				MSRP	
32"	33"	34"	WTLW3M113A16	\$49. <sup>95</sup>	

**WOOD:** Series 3 Maple  
**FINISH:** Split-Black/Natural  
**TURNING MODEL:** I13  
**SWING WEIGHT:** [4] Slight EndLoad

**TOP COAT:** Regular Finish  
**BONE RUBBED:** No  
**CUPPED:** Yes

# GENUINE ASH



MIXED ASH [SPLIT: BLACK/NATURAL]

MIXED ASH [NATURAL]

MIXED ASH [BLACK]



## MIXED ASH [SPLIT: BLACK/NATURAL]

					MSRP
31"	32"	33"	34"	WTLW3AMIXA16	\$39.95

**WOOD:** Series 3 Ash  
**FINISH:** Split Black and Natural  
**TURNING MODEL:** Mixed

**TOP COAT:** Regular Finish  
**BONE RUBBED:** No



## MIXED ASH [NATURAL]

				MSRP
32"	33"	34"	WTLW3AMIXB16	\$29.95

**WOOD:** Series 3X Ash  
**FINISH:** Natural  
**TURNING MODEL:** Mixed

**TOP COAT:** Regular Finish  
**BONE RUBBED:** No



## MIXED ASH [BLACK]

				MSRP
32"	33"	34"	WTLW3AMIXC16	\$29.95

**WOOD:** Series 3X Ash  
**FINISH:** Black  
**TURNING MODEL:** Mixed

**TOP COAT:** Regular Finish  
**BONE RUBBED:** No



# YOUTH MAPLE



YOUTH PRIME Y271™ MAPLE [NEON FADE]

YOUTH PRIME Y271™ MAPLE [BLUE ICE]

YOUTH SELECT Y243™ MAPLE [USA]

YOUTH GENUINE 125 MAPLE [SPLIT-UNFINISHED/BLACK]



**NEW**

## YOUTH PRIME Y271™ MAPLE [NEON FADE]

					MSRP
28"	29"	30"	31"	WTLWYM271B17+G	\$79. <sup>95</sup>

**WOOD:** Youth PRIME Maple **TOP COAT:** Exo Armor™ Premium Hardcoat  
**FINISH:** Fade-Black/Grey **GRIP:** Neon Yellow  
**TURNING MODEL:** Youth Y271/Balanced **CUPPED:** Yes  
**TARGET DROP:** -5 (+/- 2oz)



**NEW**

## YOUTH PRIME Y271™ MAPLE [BLUE ICE]

					MSRP
28"	29"	30"	31"	WTLWYM271A17	\$69. <sup>95</sup>

**WOOD:** Youth PRIME Maple **TARGET DROP:** -5 (+/- 2oz)  
**FINISH:** Fade-Grey/Black **TOP COAT:** Exo Armor™ Premium Hardcoat  
**TURNING MODEL:** Youth Y271/Balanced **CUPPED:** Yes



**NEW**

## YOUTH SELECT Y243™ MAPLE [USA]

					MSRP
28"	29"	30"	31"	WTLWYM243A17	\$39. <sup>95</sup>

**WOOD:** Youth SELECT Maple **TOP COAT:** HD High Gloss  
**FINISH:** Natural **CUPPED:** Yes  
**TURNING MODEL:** Youth Y243/Big Barrel



## YOUTH GENUINE 125 MAPLE [SPLIT-UNFINISHED/BLACK]

					MSRP	
27"	28"	29"	30"	31"	WTLWYM125A16	\$19. <sup>95</sup>

**WOOD:** Youth 125 Maple **TOP COAT:** Regular Finish (barrel)  
**FINISH:** Split-Unfinished/Black **CUPPED:** Yes  
**TURNING MODEL:** Standard Youth

# YOUTH ASH & ADULT SLOWPITCH



YOUTH GENUINE 125 ASH [NATURAL]

YOUTH GENUINE 225 ASH [HORNSBY]

YOUTH TEE BALL [NATURAL]

ADULT SLOWPITCH [NATURAL]



YOUTH GENUINE 125 ASH [NATURAL]

						MSRP	
27"	28"	29"	30"	31"	WTLWYA125A16	\$19. <sup>95</sup>	
ASSORTED SIZES						WTLWYA125A16AST	\$19. <sup>95</sup>

**WOOD:** Youth 125 Ash  
**FINISH:** Natural

**TURNING MODEL:** Standard Youth  
**TOP COAT:** Regular Finish (barrel)



YOUTH GENUINE 225 ASH [HORNSBY]

						MSRP	
27"	28"	29"	30"	31"	WTLWYA225A16	\$19. <sup>95</sup>	
ASSORTED SIZES						WTLWYA225A16AST	\$19. <sup>95</sup>

**WOOD:** Youth 225 Ash  
**FINISH:** Hornsby

**TURNING MODEL:** Standard Youth  
**TOP COAT:** Regular Finish



YOUTH TEE BALL [NATURAL]

			MSRP
	26"	WTLWYATEEA16	\$14. <sup>95</sup>

**WOOD:** Youth Ash  
**FINISH:** Natural

**TURNING MODEL:** Tee Ball  
**TOP COAT:** Regular Finish



ADULT SLOWPITCH [NATURAL]

			MSRP
	34"	WTLWB125SB	\$29. <sup>95</sup>

**WOOD:** Ash  
**FINISH:** Natural  
**TURNING MODEL:** Softball

**TOP COAT:** Regular Finish  
**CUPPED:** Yes  
**ASA APPROVED**



# FUNGO



S345 MAPLE [FADE-NATURAL/BLACK]

S345 MAPLE [FADE-BLACK/SILVER]

S345 MAPLE [FADE-ROYAL/WHITE]

S345 MAPLE [FADE-RED/WHITE]



S345 MAPLE [FADE-NATURAL/BLACK]

		MSRP
35"	WTLWMS345A17	\$69. <sup>95</sup>

**WOOD:** Maple **TURNING MODEL:** S345  
**FINISH:** Fade-Natural/Black **TOP COAT:** Exo Armor™ Premium Hardcoat



S345 MAPLE [FADE-BLACK/SILVER]

		MSRP
35"	WTLWMS345B17	\$69. <sup>95</sup>

**WOOD:** Maple **TURNING MODEL:** S345  
**FINISH:** Fade-Black/Silver **TOP COAT:** Exo Armor™ Premium Hardcoat



S345 MAPLE [FADE-ROYAL/WHITE]

		MSRP
35"	WTLWMS345C17	\$69. <sup>95</sup>

**WOOD:** Maple **TURNING MODEL:** S345  
**FINISH:** Fade-Royal/White **TOP COAT:** Exo Armor™ Premium Hardcoat



S345 MAPLE [FADE-RED/WHITE]

		MSRP
35"	WTLWMS345D17	\$69. <sup>95</sup>

**WOOD:** Maple **TURNING MODEL:** S345  
**FINISH:** Fade-Red/White **TOP COAT:** Exo Armor™ Premium Hardcoat

# FUNGO



S345 MAPLE (FADE-FOREST/BLACK)

S345 MAPLE (BLACK)

K100 (NATURAL)



**S345 MAPLE** [FADE-FOREST/BLACK]

		MSRP
35"	WTLWMS345E17	\$69.95

**WOOD:** Maple

**TURNING MODEL:** S345

**FINISH:** Fade-Forest/Black

**TOP COAT:** Exo Armor™ Premium Hardcoat



**S345 MAPLE** [BLACK]

		MSRP
35"	WTLWMS345F17	\$69.95

**WOOD:** Maple

**TURNING MODEL:** S345

**FINISH:** Black

**TOP COAT:** Exo Armor™ Premium Hardcoat



**K100** [NATURAL]

		MSRP
36"	WTLWBFN100	\$29.95

**WOOD:** Ash

**TURNING MODEL:** K100

**FINISH:** Natural

# TRAINING



FULL SIZE HEAVY ASH



P89 SHORT ASH



22" ONE-HANDED TRAINING ASH



18" ONE-HANDED TRAINING ASH

NJ State Approved Co-op #65MCECCPS

Metuchen/Garden State Apparel



FULL SIZE HEAVY ASH [ORANGE]

		MSRP
35"	WTLWBTRHVY-OR	\$49. <sup>95</sup>

- Full Size Heavy Bat (43-44 oz.)
- 35" versatile 5-in-1 weighted training bat



P89 SHORT BAT ASH [BLACK]

		MSRP
28"	WTLWBTRP89-BK	\$39. <sup>95</sup>

- P89 – 28" two-handed, one-handed training bat
- Short bat with regulation barrel



22" ONE-HANDED TRAINING BAT ASH [ORANGE]

		MSRP
22"	WTLWBTR1HT-OR	\$39. <sup>95</sup>

- 22" one-handed training bat
- Short bat with regulation barrel



18" ONE-HANDED TRAINING BAT ASH [BLACK]

		MSRP
18"	WTLWBTR1HT-BK	\$39. <sup>95</sup>

- 18" one-handed training bat
- Short bat with regulation barrel

Bid Term: 5/9/18 - 5/8/20



# TAKE ONE FOR YOUR TEAM.

Go to bat for your favorite Major League club with Louisville Slugger® mini MLB® bats. Each of these wood 18" bats are outfitted with the colors and logo of the MLB® team of your choice. Packaged 24 to a box, these bats can be displayed in any convenient location in your store and will fly off the shelf with ease.



Minimum Order Quantity:  
Per Team = 24 Each  
24 Each = 1 PDQ Box



WTLWT2PDQBALTC: BALTIMORE ORIOLES



WTLWT2PDQBOSTC: BOSTON RED SOX



WTLWT2PDQCHWTC: CHICAGO WHITE SOX



WTLWT2PDQCLETTC: CLEVELAND INDIANS



WTLWT2PDQDETTTC: DETROIT TIGERS



WTLWT2PDQHOUTC: HOUSTON ASTROS



WTLWT2PDQKCTC: KANSAS CITY ROYALS



WTLWT2PDQLAATC: LA ANGELS



WTLWT2PDQMINTC: MINNESOTA TWINS



WTLWT2PDQNYTTC: NEW YORK YANKEES



WTLWT2PDQOAKTC: OAKLAND ATHLETICS



WTLWT2PDQSEATC: SEATTLE MARINERS



WTLWT2PDQTBTC: TAMPA BAY RAYS



WTLWT2PDQTEXTC: TEXAS RANGERS



WTLWT2PDQORTC: TORONTO BLUE JAYS



WTLWT2PDQARITC: ARIZONA DIAMONDBACKS



WTLWT2PDQATLTC: ATLANTA BRAVES



WTLWT2PDQCHCTC: CHICAGO CUBS



WTLWT2PDQCINTC: CINCINNATI REDS



WTLWT2PDQCOLTC: COLORADO ROCKIES



WTLWT2PDQLADTC: LA DODGERS



WTLWT2PDQMIATC: MIAMI MARLINS



WTLWT2PDQMILTC: MILWAUKEE BREWERS



WTLWT2PDQNYMTC: NEW YORK METS



WTLWT2PDQPHITC: PHILADELPHIA PHILLIES



WTLWT2PDQPITTC: PITTSBURGH PIRATES



WTLWT2PDQSDTC: SAN DIEGO PADRES



WTLWT2PDQSFTC: SAN FRANCISCO GIANTS



WTLWT2PDQSTLTC: ST LOUIS CARDINALS



WTLWT2PDQWSHTC: WASHINGTON NATIONALS



TOP COLLEGIATE PROGRAMS



FASTPITCH BATS

The all-new 2018 Louisville Slugger® Fastpitch is our best lineup to date. Our player focused approach helped us to design a bat for every player type from youth to college to the pros. The new PXT™ bat was designed for hitters that want power on contact, the lightweight swing speed of the LXT™ is for hitters that want maximum speed, and the XENO™ has a huge sweet spot that every player wants. Own the plate with the best bats in the game.

# BATS

## FASTPITCH



# FASTPITCH

## 2 1/4" BARREL



PXT™ X18

LXT™ X18

XENO™ X18

NJ State Approved Co-op #65MCESCCPS

Metuchen/Garden State Apparel

Bid Term: 5/9/18 - 5/8/20



### PXT™ X18 [-10] [-9] [-8]

							MSRP
30"/20	31"/21	32"/22	33"/23	34"/24	WTLFPPX18A10	-10	\$399. <sup>95</sup>
		32"/23	33"/24	34"/25	WTLFPPX18A9	-9	\$399. <sup>95</sup>
			33"/25	34"/26	WTLFPPX18A8	-8	\$399. <sup>95</sup>

- 100% Composite Design
- **NEW** PWR STAX™ barrel technology evenly distributes the load on impact across the entire barrel for maximum performance
- Performance Balanced swing weight for elite hitters
- **NEW** ultra-light weight X-Cap™ gives you improved swing speed and better durability
- Patented TRU3™ construction that reduces vibration and provides unmatched feel on contact
- **NEW**–Premium X-Grip with medium tack feel—engineered specifically for fast pitch players
- 7/8" standard fast pitch handle diameter



### LXT™ X18 [-11] [-10] [-9] [-8]

							MSRP	
28"/17	29"/18	30"/19	31"/20	32"/21	33"/22	WTLFPLX18A11	-11	\$349. <sup>95</sup>
	30"/20	31"/21	32"/22	33"/23	34"/24	WTLFPLX18A10	-10	\$349. <sup>95</sup>
		32"/23	33"/24	34"/25		WTLFPLX18A9	-9	\$349. <sup>95</sup>
			33"/25	34"/26		WTLFPLX18A8	-8	\$349. <sup>95</sup>

- 100% Composite Design
- Patented PBF™ Barrel Technology provides one of the largest sweet spot in the LS fastpitch line
- Ultra-Balanced swing weight for maximum swing speed
- **NEW** ultra-light weight X-Cap™ design gives you improved swing speed and better durability
- Patented TRU3™ construction that reduces vibration and provides unmatched feel on contact
- 7/8" standard fast pitch handle diameter and synthetic comfort grip



### XENO™ X18 [-11] [-10] [-9] [-8]

							MSRP
29"/18	30"/19	31"/20	32"/21	33"/22	WTLFPXN18A11	-11	\$299. <sup>95</sup>
30"/20	31"/21	32"/22	33"/23	34"/24	WTLFPXN18A10	-10	\$299. <sup>95</sup>
		32"/23	33"/24	34"/25	WTLFPXN18A9	-9	\$299. <sup>95</sup>
			33"/25	34"/26	WTLFPXN18A8	-8	\$299. <sup>95</sup>

- 100% Composite Design
- Patented S11D™ Barrel Technology provides maximum pop on contact
- Balanced swing weight perfect for all player types
- **NEW** ultra-light weight X-Cap™ design gives you improved swing speed and better durability
- IST™ Xstiff Technology - 2-piece construction with a stiffer feel for increased energy transfer
- 7/8" standard fast pitch handle diameter and synthetic comfort grip



# FASTPITCH

## 2 1/4" BARREL



X12

PROVEN™

QUEST™

DIVA™



### X12 [-12]

							MSRP
28"/16	29"/17	30"/18	31"/19	32"/20	33"/21	WTLFPX218A12	-12 \$199.95

- 100% Light weight C1C™ Composite Design
- 2pc construction for minimal vibration on contact
- Great option for younger players who want maximum control and increased reaction time
- 7/8" standard fast pitch handle diameter and synthetic comfort grip



### PROVEN™ [-13]

							MSRP
28"/15	29"/16	30"/17	31"/18	32"/19	33"/20	WTLFPPR18A13	-13 \$99.95

- 100% Composite design at an unbelievable value
- 1pc construction for a more solid feel on contact
- Great option for younger players who want increased bat speed and max control
- 7/8" standard fast pitch handle diameter and synthetic comfort grip



### QUEST™ [-12]

							MSRP
	27"/15	28"/16	29"/17	30"/18		WTLFPQU18A12	-12 \$59.95
		31"/19	32"/20	33"/21			

- 1pc performance alloy construction gives you better durability with great pop
- Take your game to the next level with the reliable performance of the Quest FP bat
- 7/8" standard fast pitch handle diameter and standard FP grip



### DIVA™ [-11.5]

							MSRP
27"/15.5	28"/16.5	29"/17.5	30"/18.5	31"/19.5		WTLFPDV18A115	-11.5 \$29.95

- 1pc performance alloy construction at a great value
- Designed specifically for youth players
- 7/8" standard fast pitch handle diameter and standard FP grip



SLOWPITCH BATS

Louisville Slugger's powerful lineup of Slowpitch bats feature the ultimate tool for every type of player. From balanced to end-loaded bats, hitters in every association can step into the batter's box with confidence and a bat that matches their game.

# BATS

## SLOWPITCH

# USSSA

## 2 1/4" BARREL



SLOWPITCH BATS



Z4 BALANCED

Z4 ENDOADED

SUPER Z® BALANCED

SUPER Z® ENDOADED

SOLO Z POWERLOAD



Z4 BALANCED

				MSRP
34"/26	34"/27	34"/28	WTLZ4U17B	\$299. <sup>95</sup>

- Patented TRU3™ construction that reduces vibration and provides unmatched feel on contact
- 100% composite design for maximum performance
- Balanced swing weight for faster swing speed and better control
- Friction Blast Finish on the barrel
- 7/8" tapered handle



Z4 ENDOADED

				MSRP
34"/26	34"/27	34"/28	WTLZ4U17E	\$299. <sup>95</sup>

- Patented TRU3™ construction that reduces vibration and provides unmatched feel on contact
- 100% composite design for maximum performance
- End load swing weight for max power and energy transfer on contact
- Friction Blast Finish on the barrel
- 7/8" tapered handle



SUPER Z® BALANCED

				MSRP
34"/26	34"/27	34"/28	WTLZSU17B	\$299. <sup>95</sup>

- IST Xstiff Technology—2-piece construction with a stiffer feel for increased energy transfer
- Balanced swing weight for faster swing speed and better control
- Friction Blast Finish on the barrel
- 7/8" tapered handle



SUPER Z® ENDOADED

				MSRP
34"/26	34"/27	34"/28	WTLZSU17E	\$299. <sup>95</sup>

- Kevin Kennington Signature Model
- IST Xstiff Technology—2-piece construction with a stiffer feel for increased energy transfer
- End load swing weight for max power and energy transfer on contact
- Friction Blast Finish on the barrel
- 7/8" tapered handle



SOLO Z POWERLOAD

				MSRP
34"/26.5	34"/27.5	34"/28.5	WTLZSU16PL	\$199. <sup>95</sup>

- FOR RETAILERS ONLY
- 1-piece composite construction and power loaded swing weight adds an additional +0.5 oz for max power
- Friction Blast Finish on the barrel



# ASA & SENIOR SOFTBALL

## 2 1/4" BARREL



Z4 BALANCED

Z4 ENDOADED

SUPER Z ENDOADED

SOLO Z BALANCED

HYPER Z ENDOADED [SENIOR]



Z4 BALANCED

				MSRP
34"/26	34"/27	34"/28	WTLZ4A17B	\$299. <sup>95</sup>

- Patented TRU3™ construction that reduces vibration and provides unmatched feel on contact
- 100% composite design for maximum performance
- Balanced swing weight for faster swing speed and better control
- Friction Blast Finish on the barrel
- S11D Barrel Technology provides maximum pop on contact
- 7/8" tapered handle



Z4 ENDOADED

				MSRP
34"/26	34"/27	34"/28	WTLZ4A17E	\$299. <sup>95</sup>

- Patented TRU3™ construction that reduces vibration and provides unmatched feel on contact
- 100% composite design for maximum performance
- End load swing weight for max power and energy transfer on contact
- Friction Blast Finish on the barrel
- S11D Barrel Technology provides maximum pop right out of the wrapper
- 7/8" tapered handle



SUPER Z ENDOADED

				MSRP
34"/26	34"/27	34"/28	WTLZSA17E	\$299. <sup>95</sup>

- IST Xstiff Technology—2-piece construction with a stiffer feel for increased energy transfer
- S11D Barrel Technology provides max pop right out of the wrapper
- End load swing weight for max power and energy transfer on contact
- Friction Blast Finish on the barrel
- 7/8" tapered handle



SOLO Z BALANCED

				MSRP
34"/26	34"/27	34"/28	WTLZSA16B	\$199. <sup>95</sup>

- 1 piece 100% composite construction for improved energy transfer on contact
- Balanced swing weight for faster swing speed and better control
- Friction Blast Finish on the barrel
- 7/8" tapered handle



HYPER Z ENDOADED [SENIOR]

				MSRP
34"/26.5	34"/27.5	34"/28.5	WTLZS17E	\$219. <sup>95</sup>

- Approved for play in all Senior Softball associations
- NO WARRANTY
- Rob Parnell Signature Model
- 100% composite design for maximum performance
- Patented TRU3™ construction that reduces vibration and provides unmatched feel on contact
- End load swing weight for max power and energy transfer on contact
- Friction Blast Finish on the barrel

# BATTING GLOVES



BATTING GLOVES



# PRIME & SERIES 7 BATTING GLOVES

NEW



PRIME



SERIES 7

NJ State Approved Co-op #65MCECCPS

Metuchen/Garden State Apparel

Bid Term: 5/9/18 - 5/8/20

## PRIME



		MSRP
WTL6102	MEN'S SIZES: S-2XL	\$39. <sup>99</sup>

**FUNCTION** Premium embossed sheepskin leather palm for strong grip and a superior feel

**FLEXIBILITY** Wave spandex joints for maximum flexibility and breathability

**FIT** Form-fitting, elastic wrist cuff for precise comfort fit



## SERIES 7

		MSRP
WTL6101	MEN'S SIZES: S-2XL	\$29. <sup>99</sup>
WTL6301	YOUTH SIZES: S-L	\$29. <sup>99</sup>

**FUNCTION** Digital embossed sheepskin leather palm for maximum comfort and grip

**FLEXIBILITY** 4-way stretch diamond mesh backhand for flexibility and improved airflow

**FIT** Ribbed, moisture wicking neoprene wrist strap for comfort fit and support





# OMAHA & GENUINE BATTING GLOVES

NEW



OMAHA

NEW



GENUINE

## OMAHA

		MSRP
WTL6103	MEN'S SIZES: S-2XL	\$19.99
WTL6303	YOUTH SIZES: S-L	\$19.99

**FUNCTION** Digital embossed goatskin leather palm for improved grip and durability  
**FLEXIBILITY** Strategic finger perforation for improved flexibility and breathability  
**FIT** Neoprene wrist strap for comfort fit and support



## GENUINE

		MSRP
WTL6104	MEN'S SIZES: S-2XL	\$14.99
WTL6304	YOUTH SIZES: S-L	\$14.99

**FUNCTION** One-piece embossed synthetic palm and thumb for no-slip grip  
**FLEXIBILITY** Stretch mesh on backhand for better mobility, flexibility and breathability  
**FIT** Neoprene wrist strap for comfort fit and support





# GLOVES





# TPX<sup>®</sup>

## PRO PATTERNS. PRO MATERIALS. YOUR GLOVE.

Louisville Slugger's new TPX<sup>®</sup> gloves are inspired by professional-style patterns that elite ballplayers have relied on for generations. Top materials – down to the detail – built together for a top-shelf ball glove.

- 1. TOP SHELF LEATHER:**  
Premium grade ball glove leather from one of the world's finest tanneries.
- 2. ALL NEW PROFESSIONAL PATTERNS:**  
Redesigned from scratch by our glove experts for optimal performance.
- 3. PROFESSIONAL GRADE SUB-MATERIALS:**  
The details matter—thread, felt, inserts, etc.—every component is thoroughly tested and certified by our R&D team to maximize performance.

NEW



**INFIELD** 11.25"  
STOCK NO.  
WTLPXR181125  
MSRP  
\$149.95

- H-Web
- Brown and White

NEW



**INFIELD** 11.5"  
STOCK NO.  
WTLPXR181115  
MSRP  
\$149.95

- H-Web
- Brown and Red

NEW



**INFIELD** 11.5"  
STOCK NO.  
WTLPXR181152  
MSRP  
\$149.95

- H-Web
- Brown and White

NEW



**INFIELD** 11.75"  
STOCK NO.  
WTLPXR181175  
MSRP  
\$149.95

- Dual Post Web
- Brown and White

NEW



**PITCHER** 11.75"  
STOCK NO.  
WTLPXR1875P  
WTLPXL1875P [LHT]  
MSRP  
\$149.95

- Basket Web with Weave
- Brown

NEW



**OUTFIELD** 12.75"  
STOCK NO.  
WTLPXR181275  
WTLPXL181275 [LHT]  
MSRP  
\$149.95

- Single Post Web
- Brown



# OMAHA®

SKIP THE BREAK IN.  
STORM THE FIELD.



Designed with the young, avid travel baseball player in mind, the Omaha® requires minimal break-in thanks to its soft leather construction. With a line of six professional patterns to outfit every player on the diamond, no glove helps you cover more ground.

**1. SIX PROFESSIONAL PATTERNS:**

The right glove for you no matter what positions you play.

**2. SOFT FULL-GRAIN STEERHIDE LEATHER:**

Minimal break-in, so you can take it right to the field.



**INFIELD 11.25"**

STOCK NO.  
WTLOMRB171125  
MSRP  
\$99.95

- H-Web
- Black and Gray



**INFIELD 11.5"**

STOCK NO.  
WTLOMRB17115  
MSRP  
\$99.95

- Dual Post Web
- Black and Gray



**PITCHER 11.75"**

STOCK NO.  
WTLOMRB171175  
WTLOMLB171175 [LHT]  
MSRP  
\$99.95

- Pro Laced T-Web
- Black and Gray



**OUTFIELD 12.5"**

STOCK NO.  
WTLOMRB17125  
WTLOMLB17125 [LHT]  
MSRP  
\$99.95

- Single Post Web
- Black and Gray



**1ST BASE 12"**

STOCK NO.  
WTLOMRB17BM  
WTLOMLB17BM [LHT]  
MSRP  
\$99.95

- Single Post Web
- Black and Gray



**CATCHER 32"**

STOCK NO.  
WTLOMRB17CM  
MSRP  
\$99.95

- Half Moon Web
- Black and Gray

# 125 SERIES

**SUPERIOR FEEL.  
CAPABLE CONSTRUCTION.**

With soft leather, the 125 Series is ideal for players looking for minimal break-in. It is more than capable for young players and weekend warriors alike.

1. **SOFT COWHIDE LEATHER:**  
For minimum break-in.
2. **PATTERNS:**  
Both adult and youth patterns.
3. **ADULT OR YOUTH:**  
Great for the youth player or adult weekend warrior.



**INFIELD** 11.25"  
STOCK NO.  
WTL12RB171125  
MSRP  
\$79.95  
• H-Web  
• Cream



**INFIELD** 11.5"  
STOCK NO.  
WTL12RB17115  
WTL12LB17115 [LHT]  
MSRP  
\$79.95  
• H-Web  
• Cream



**PITCHER** 12"  
STOCK NO.  
WTL12RB1712  
WTL12LB1712 [LHT]  
MSRP  
\$79.95  
• Weave Web  
• Cream



**OUTFIELD** 12.5"  
STOCK NO.  
WTL12RB17125  
WTL12LB17125 [LHT]  
MSRP  
\$79.95  
• Single Post Web  
• Cream



**CATCHER** 33"  
STOCK NO.  
WTL12RB17CM  
MSRP  
\$79.95  
• 2-Piece Web  
• Cream

### DYNASTY



**INFIELD** 11"  
 STOCK NO.  
 WTLDYRB1711  
 MSRP  
 \$59.95

- Closed Weave Web
- Caramel



**INFIELD** 11.5"  
 STOCK NO.  
 WTLDYRB17115  
 WTLDYLB17115 [LHT]  
 MSRP  
 \$59.95

- H-Web
- Caramel



**PITCHER** 12"  
 STOCK NO.  
 WTLDYRB1712  
 WTLDYLB1712 [LHT]  
 MSRP  
 \$59.95

- Closed Weave Web
- Caramel



**OUTFIELD** 12.25"  
 STOCK NO.  
 WTLDYRB171225  
 WTLDYLB171225 [LHT]  
 MSRP  
 \$59.95

- Dual Post Web
- Caramel

### GENESIS



**INFIELD** 10"  
 STOCK NO.  
 WTLFGGN14-BN100REG  
 MSRP  
 \$34.95

- Weave Web
- Saddle Tan and Black



**INFIELD** 10.5"  
 STOCK NO.  
 WTLFGGN14-BN105REG  
 WTLFGGN14-BN105LHT [LHT]  
 MSRP  
 \$34.95

- Weave Web
- Saddle Tan and Black



**PITCHER** 11"  
 STOCK NO.  
 WTLFGGN14-BN110REG  
 MSRP  
 \$34.95

- Weave Web
- Saddle Tan and Black



**OUTFIELD** 11.5"  
 STOCK NO.  
 WTLFGGN14-BN115REG  
 WTLFGGN14-BN115LHT [LHT]  
 MSRP  
 \$34.95

- Closed Channel Web
- Saddle Tan and Black



**PITCHER** 12"  
 STOCK NO.  
 WTLFGGN14-BN120REG  
 WTLFGGN14-BN120LHT [LHT]  
 MSRP  
 \$34.95

- Closed Channel Web
- Saddle Tan and Black



# LXT™

## THE PREMIER FASTPITCH OPTION.



1. **X-SPAND WRIST OPENING:**  
The perfect fit no matter what size hand.
2. **FULL-GRAIN STEERHIDE LEATHER:**  
For maximum durability.
3. **FEMALE-SPECIFIC PATTERNS:**  
Additional comfort for smaller hands.

Used by the top players, the LXT™ has established itself as the finest Fastpitch glove in play. Double-oiled leather makes the LXT exceptionally soft yet unequivocally durable.

FASTPITCH GLOVES



**INFIELD** 11.75"  
STOCK NO.  
WTLXRF171175  
MSRP  
\$199.95

- Dual Post Web
- X-Spand Wrist
- Dark Brown and White



**PITCHER** 12"  
STOCK NO.  
WTLXRF1712  
WTLXLF1712 [LHT]  
MSRP  
\$199.95

- Reinforced Weave Web
- X-Spand Wrist
- Dark Brown and White



**OUTFIELD** 12.5"  
STOCK NO.  
WTLXRF17125  
WTLXLF17125 [LHT]  
MSRP  
\$199.95

- Dual Post Web
- X-Spand Wrist
- Dark Brown and White



**1ST BASE** 13"  
STOCK NO.  
WTLXRF17BM  
WTLXLF17BM [LHT]  
MSRP  
\$199.95

- Dual Post Web
- X-Spand Wrist
- Dark Brown and White



**CATCHER** 33"  
STOCK NO.  
WTLXRF17CM  
MSRP  
\$199.95

- Dual Post Web
- X-Spand Wrist
- Dark Brown and White



# XENO®

SOFT FEEL.  
SOLID CONSTRUCTION.  
STYLISH LOOK.

When top-of-the-line leather meets a soft lining, a game ready glove like no other is born. The Xeno® is stylish and provides a sure feel designed specifically for the female player.

1. **MINIMAL BREAK-IN:**  
Pre-conditioned, field-ready. Comfortable upon first wear.
2. **SOFT PIGSKIN WRIST LINING:**  
Reinforced support provides a more secure fit.
3. **FEMALE-SPECIFIC PATTERS:**  
Additional comfort for smaller hands.



**INFIELD** 11.75"  
STOCK NO.  
WTLXNRF171175  
MSRP  
\$99.95

- Dual Post Web
- Black and White



**INFIELD** 12"  
STOCK NO.  
WTLXNRF1712  
WTLXNLF1712 [LHT]  
MSRP  
\$99.95

- Closed Weave Web
- Black and White



**PITCHER** 12.5"  
STOCK NO.  
WTLXNRF17125  
WTLXNLF17125 [LHT]  
MSRP  
\$99.95

- Dual Post Web
- Black and White



**OUTFIELD** 12.75"  
STOCK NO.  
WTLXNRF171275  
WTLXNLF171275 [LHT]  
MSRP  
\$99.95

- Closed Weave Web
- Black and White



**1ST BASE** 13"  
STOCK NO.  
WTLXNRF17BM  
WTLXNLF17BM [LHT]  
MSRP  
\$99.95

- Dual Post Web
- Black and White



**CATCHER** 33"  
STOCK NO.  
WTLXNRF17CM  
MSRP  
\$99.95

- Dual Post Web
- Black and White

## DIVA™



**INFIELD** 10.5"  
STOCK NO.  
WTLDVRF17105  
MSRP  
\$29.95

- Flash Web
- Silver and Hyper



**INFIELD** 11"  
STOCK NO.  
WTLDVRF1711  
WTLDVLF1711 [LHT]  
MSRP  
\$29.95

- Victory Web
- Silver and Hyper



**PITCHER** 11.5"  
STOCK NO.  
WTLDVRF17115  
WTLDVLF17115 [LHT]  
MSRP  
\$34.95

- Flash Web
- Silver and Hyper

# TPS™

## PREMIUM-GRADE LEATHER FOR A PREMIUM PERFORMANCE.

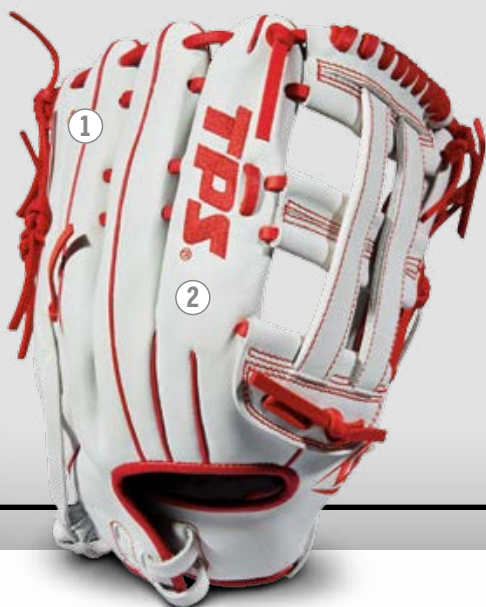

1. **TOP SHELF LEATHER:**  
Premium grade ball glove leather from one of the world's finest tanneries.
2. **PROFESSIONAL GRADE SUB-MATERIALS:**  
The details matter—thread, felt, inserts, etc.—every component is thoroughly tested and certified by our R&D team to maximize performance.

The new TPS™ line of ball gloves is built with top-of-the-line leather, and is designed, assembled and tested with maximum performance in mind.

SLOWPITCH GLOVES

NEW



**INFIELD** 13"  
STOCK NO.  
WTLPSRS1813  
MSRP  
\$169.95

- Dual Post Web
- Red and White

NEW



**INFIELD** 13.5"  
STOCK NO.  
WTLPSRS18135  
WTLPSLS18135 [LHT]  
MSRP  
\$169.95

- Single Post Web
- Red and White

NEW



**PITCHER** 14"  
STOCK NO.  
WTLPSRS1814  
WTLPSLS1814 [LHT]  
MSRP  
\$169.95

- Dual Post Web
- Red and White

### SLOWPITCH DYNASTY



**INFIELD** 13"  
STOCK NO.  
WTLDYRS1713  
WTLDYLS1713 [LHT]  
MSRP  
\$69.95

- Single Post Web
- Caramel colored leather



**INFIELD** 14"  
STOCK NO.  
WTLDYRS1714  
WTLDYLS1714 [LHT]  
MSRP  
\$69.95

- Dual Post Web
- Caramel colored leather





PROTECTIVE

# PROTECTIVE GEAR



# SERIES 5

## 3-PIECE YOUTH CATCHER'S SET

Made from extra-tough, lightweight materials that keep you protected while easily moving with you. Available in a variety of color combinations, the Louisville Slugger Series 5 Youth Catcher's Sets will keep catchers of every skill level safe and in the game.



### SERIES 5 3-PIECE CATCHER'S SET

		MSRP
WTLPGS514-STY	YOUTH	\$179. <sup>99</sup>

#### HELMET

- Glossy finish
- Moisture wicking chin pad
- Meets NOCSAE protection standard
- Size: 6<sup>3</sup>/<sub>8</sub>-7<sup>1</sup>/<sub>8</sub>

#### CHEST PROTECTOR

- High-density foam padding
- Over-the-shoulder harness
- Precision pad design
- Size: 12"

#### SHIN GUARDS

- Anatomically inspired double-knee design
- Size: 13"

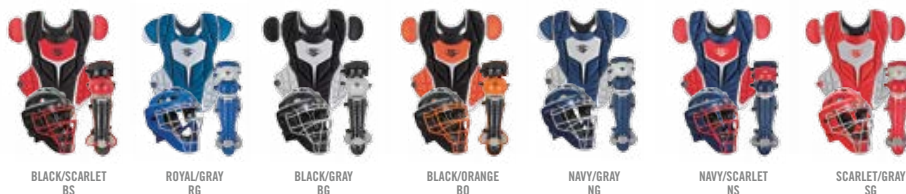

BLACK/SCARLET  
BS

ROYAL/GRAY  
RG

BLACK/GRAY  
BG

BLACK/ORANGE  
BO

NAVY/GRAY  
NG

NAVY/SCARLET  
NS

SCARLET/GRAY  
SG



# GEAR BAGS



GEAR BAGS



AN OFFICIAL EQUIPMENT BAG LICENSEE OF MAJOR LEAGUE BASEBALL



# PRIME

NEW



PRIME

NEW



RIG

## PRIME STICK PACK

WTL9902	14" W x 9" D x 23" H	MSRP \$99. <sup>95</sup>
---------	----------------------	-----------------------------

- LARGE MAIN COMPARTMENT** fits facemask, glove, cleats and more
- BAT SLEEVES** 4 molded neoprene sleeves
- FLEECE LINED** valuables pocket
- INTERIOR SHELF** with pockets
- DURABLE J** style fence hook
- 2 1/2" MAIN COMPARTMENT** expansion zipper
- FOAM PADDED** shoulder straps
- REMOVABLE CUSTOMIZATION** area fits on 15" hoop



## PRIME RIG WHEELED

WTL9901	39" L x 14" W x 14" H	MSRP \$179. <sup>95</sup>
---------	-----------------------	------------------------------

- MAIN COMPARTMENT** fits helmet, glove, cleats and more
- BAT COMPARTMENT** 4 interior padded slots for bats
- 2 EXTERIOR POCKETS** fits 2 additional 34" bats in each pocket
- INTERIOR SHELVES** to separate gear throughout the bag
- FLEECE LINED** valuables pocket
- SHOE COMPARTMENT** vented
- HIGH RISE** Wheel Chassis with 3" clearance and inline wheels
- SIZE 10** zippers on front openings
- RIGID BOTTOM AND RAILS** stabilize rolling
- DURABLE J** style fence hooks [2]
- INTERIOR SNAP IN BRACES** to help the bag stand up straight
- 4 INTERNAL** accessory pockets
- REMOVABLE CUSTOMIZATION** area fits on 15" hoop



# SELECT

**NEW**



SELECT

**NEW**



RIG

## SELECT STICK PACK

WTL9702	12.5" W x 9" D x 20" H	MSRP \$59. <sup>95</sup>
---------	------------------------	-----------------------------

- MAIN COMPARTMENT** fits helmet, glove, cleats and gear
- BAT SLEEVES** 2 molded neoprene sleeves with wood grain emboss
- LOCKER STYLE** main opening
- FLEECE LINED** valuables pocket
- DURABLE** J style fence hook
- FOAM PADDED** shoulder straps
- TARPAULIN WATERPROOF** shoe compartment
- FRONT LOAD HANDLES**
- REMOVABLE CUSTOMIZATION** area fits onto 12" hoop



## SELECT RIG WHEELED

WTL9701	38" L x 14" W x 13.5" H	MSRP \$119. <sup>95</sup>
---------	-------------------------	------------------------------

- MAIN COMPARTMENT** fits helmet, glove, cleats and catcher's gear
- BAT COMPARTMENT** fits 4 bats
- HIGH RISE** Wheel Chassis with 3" clearance and rugged wheels
- DURABLE** J style fence hooks [2]
- INTERIOR SHELVES** to separate glove from the rest of your gear
- LARGE SIDE POCKETS** [2] for valuables and catchers gear
- SIZE 10** zippers on front openings
- RIGID BOTTOM AND RAILS** stabilize rolling
- FRONT LOAD HANDLES**
- REMOVABLE CUSTOMIZATION** area fits onto 15" hoop





# SERIES 5 OMAHA



STICK PACK



RIG



TON

## SERIES 5 OMAHA STICK PACK

		<b>MSRP</b>
WTL9501	12" W x 7.5" D x 18" H	\$39. <sup>95</sup>

- MAIN COMPARTMENT** fits helmet with mask, glove and cleats
- MESH BAT SLEEVES** hold up to 2 bats, doubles as water bottle holder
- FRONT PANEL** for easy decoration
- FRONT CARGO POCKET** for shoes or gear
- DURABLE** J style fence hook
- FOAM** padded shoulder straps



## SERIES 5 OMAHA RIG™

		<b>MSRP</b>
WTL9502	37" L x 12.5" W x 12" H	\$69. <sup>95</sup>

- MAIN COMPARTMENT** fits helmet, glove and gear
- BAT SLEEVES** hold up to 4 bats comfortably
- REMOVABLE** top embroidery panel (Fits onto 12" Hoop)
- SEPARATE** shoe compartment
- RUGGED WHEELS** with structured bottom built to last
- DURABLE** J style fence hook
- SIDE POCKET** for miscellaneous storage



## SERIES 5 OMAHA TON™

		<b>MSRP</b>
WTL9503	40" L x 16" W x 16" H	\$69. <sup>95</sup>

- OVERSIZED** multi-purpose gear bag
- REINFORCED** carry handles
- RIGID BOTTOM** with support rails
- FITS** helmet with facemask and all other gear



# GENUINE

NEW



## GENUINE STICK PACK

		MSRP
WTL9302	11" W x 9" D x 17" H	\$29. <sup>95</sup>

- BAT SLEEVES** Holds up to 2 full size bats
- MAIN COMPARTMENT** Fits helmet, glove and youth cleats
- ZIPPERED** valuables pocket
- DURABLE** J style fence hook
- FOAM PADDED** shoulder straps
- CUSTOMIZATION** area



## GENUINE MLB® STICK PACK

		MSRP
WTL9302TC	11" W x 9" D x 17" H	\$34. <sup>95</sup>

- BAT SLEEVES** Holds up to 2 full size bats
- MAIN COMPARTMENT** Fits helmet, glove and youth cleats
- ZIPPERED** valuables pocket
- DURABLE** J style fence hook
- FOAM PADDED** shoulder straps
- CUSTOMIZATION** area
- MLB** branding

### AL EAST



NEW YORK YANKEES WTL9302TCNY  
 BOSTON RED SOX WTL9302TCBOS  
 BALTIMORE ORIOLLES WTL9302TCBAL  
 TAMPA BAY RAYS WTL9302TCB  
 TORONTO BLUE JAYS WTL9302TCOR

### AL CENTRAL



CLEVELAND INDIANS WTL9302TCCL  
 CHICAGO WHITE SOX WTL9302TCWS  
 DETROIT TIGERS WTL9302TCDT  
 KANSAS CITY ROYALS WTL9302TCKC  
 MINNESOTA TWINS WTL9302TCMN

### AL WEST



HOUSTON ASTROS WTL9302TCHOU  
 LOS ANGELES ANGELS WTL9302TCLA  
 OAKLAND ATHLETICS WTL9302TCOAK  
 SEATTLE MARINERS WTL9302TCSEA  
 TEXAS RANGERS WTL9302TCTEX

### NL EAST



ATLANTA BRAVES WTL9302TCATL  
 MIAMI MARLINS WTL9302TCMIA  
 NEW YORK METS WTL9302TCNYM  
 PHILADELPHIA PHILLIES WTL9302TCPHI  
 WASHINGTON NATIONALS WTL9302TCWSH

### NL CENTRAL



CHICAGO CUBS WTL9302TCCHC  
 CINCINNATI REDS WTL9302TCCIN  
 MILWAUKEE BREWERS WTL9302TCMIL  
 PITTSBURGH PIRATES WTL9302TCPIT  
 ST. LOUIS CARDINALS WTL9302TCSTL

### NL WEST



ARIZONA DIAMONDBACKS WTL9302TCARI  
 COLORADO ROCKIES WTL9302TCCOL  
 LOS ANGELES DODGERS WTL9302TCLAD  
 SAN FRANCISCO GIANTS WTL9302TCSF  
 SAN DIEGO PADRES WTL9302TCDSD



**GARY SANCHEZ**  
New York Yankees, C

**SIERRA ROMERO**  
USSSA Pride, 2B

**MIGUEL CABRERA**  
Detroit Tigers, IF

**WE ARE ATHLETES** It's in our blood to create competitive advantages. Failure is not an option. Our brand is the symbolic battle cry of those that sacrifice for team, for pride, for victory.



**EVOSHIELD**





OFFICIAL PROTECTIVE GEAR SUPPLIER  
OF MAJOR LEAGUE BASEBALL.  
MAJOR LEAGUE BASEBALL TRADEMARKS AND COPYRIGHTS ARE USED WITH  
PERMISSION OF MAJOR LEAGUE BASEBALL PROPERTIES, INC. VISIT MLB.COM

# PROTECTIVE GEAR



**CARLOS CORREA**  
Houston Astros, SS

**SIERRA ROMERO**  
USSSA Pride, 2B



### STEP 1

## RIP IT.

Rip open the foil bag and remove the soft Shields to begin the custom molding process. Exposing the protective Shield to air activates EvoShield's Gel-to-Shell Technology.™



### STEP 2

## FIT IT.

Place the soft, flexible Shield in position and smooth any wrinkles. The Shield will begin to harden in about 10 minutes.



### STEP 3

## WEAR IT.

Wear the Shield for 30 minutes until the transformation from Gel-to-Shell™ is complete. Once fitted, the Shield is permanently formed to your body shape and is ready to provide protection all season long.







BLACK

**NEW EVOCHARGE™  
BATTER'S ELBOW GUARD**

**CSTM-MLD**

		MSRP
WTV6100	ADULT: ONE SIZE	\$44. <sup>99</sup>
WTV6101	YOUTH: ONE SIZE (BLACK, RED & ROYAL ONLY)	\$39. <sup>99</sup>

GEL-TO-SHELL™ TECHNOLOGY: begins soft and flexible, transforms to hard and protective in minutes  
 IMPACT IS DISPERSED: not absorbed  
 CUSTOM-MOLDING SHIELD: molds to user's body shape, ensuring a perfect fit, custom molds to fit left or right handed hitters  
 SHIELD IS HAND WASHABLE: air dry  
 ADULT COVERAGE: 9"W X 6"H  
 YOUTH SHIN COVERAGE: 8"W x 5"H

**CONTAINS:** 1 custom-molding protective elbow shield, 1 elastic strap, gauze  
**FABRIC:** 100% Polyester



BLACK

**NEW EVOCHARGE™  
BATTER'S LEG GUARD**

**CSTM-MLD**

		MSRP
WTV1100	ADULT: ONE SIZE	\$59. <sup>99</sup>
WTV1101	YOUTH: ONE SIZE (BLACK, RED & ROYAL ONLY)	\$54. <sup>99</sup>

GEL-TO-SHELL™ TECHNOLOGY: begins soft and flexible, transforms to hard and protective in minutes  
 IMPACT IS DISPERSED: not absorbed  
 CUSTOM-MOLDING SHIELD: molds to user's body shape, ensuring a perfect fit, custom molds to fit left or right handed hitters  
 SHIELD IS HAND WASHABLE: air dry  
 ADULT SHIN COVERAGE: 6 5/8"W x 10 5/16"L  
 YOUTH SHIN COVERAGE: 5 1/8"W x 8 3/4"L

**CONTAINS:** 1 custom-molding protective leg shield, 1 custom-molding protective foot shield (detachable), 2 elastic leg straps, 1 elastic foot strap, 1 elastic connector piece and gauze  
**FABRIC:** 100% Polyester



BLACK

**NEW EVOCHARGE™  
PROTECTIVE WRIST GUARD**

**CSTM-MLD**

		MSRP
WTV5100	S, M, L, XL	\$24. <sup>99</sup>

GEL-TO-SHELL™ TECHNOLOGY: begins soft and flexible, transforms to hard and protective in minutes  
 PROVIDES: the compression of tape, comfort of neoprene, and protection of a shield  
 IMPACT IS DISPERSED: not absorbed  
 CUSTOM-MOLDING SHIELD: molds to user's body shape, ensuring a perfect fit  
 SHIELD IS HAND WASHABLE: air dry  
 SHIELD COVERAGE: 3"W x 4"L  
 SLEEVE COVERAGE: 5"L

**CONTAINS:** 1 performance neoprene wrist sleeve and 1 custom-molding protective wrist shield  
**FABRIC:** 100% Neoprene





BACK VIEW

**PROTECTIVE SLIDING WRIST**

		MSRP
WTV2044154	LEFT HAND: S/M, L/XL	\$44. <sup>99</sup>
WTV2044155	RIGHT HAND: S/M, L/XL	\$44. <sup>99</sup>

ADJUSTABLE WRIST SUPPORT: for top and bottom of wrist  
 ELASTIC COMPRESSION STRAP: secures wrist  
 SINGLE STRAP: for quick on and off  
 SLIDING WRIST SLEEVE: hand washable, air dry  
 MEASURED IN INCHES AROUND THE WRIST: S/M - 5"-7"; L/XL - 7"+

**CONTAINS:** 1 sliding wrist, 1 dorsal splint, and 1 palmar splint  
**FABRIC:** 100% Neoprene



**CATCHER'S THUMB GUARD**

**CSTM-MLD**

		MSRP
WTV2044130	S, L	\$24. <sup>99</sup>

GEL-TO-SHELL™ TECHNOLOGY: begins soft and flexible, transforms to hard and protective in minutes  
 CUSTOM-MOLDING SHIELD: molds to user's body shape, ensuring a perfect fit, molds to fit left or right thumb, worn under glove  
 IMPACT IS DISPERSED: not absorbed  
 SHIELD IS HAND WASHABLE: air dry  
 LARGE COVERAGE: 4.5" x 4.5"  
 SMALL COVERAGE: 4.5" x 3.25"

**CONTAINS:** 1 custom-molding, protective hourglass shaped shield, gauze  
**FABRIC:** 100% Polyester







**MEN'S SLEEVELESS CHEST GUARD**

**CSTM-MLD**

		MSRP
WTV1047102	MEN'S: S, M, L	\$59.99
WTV1047103	BOYS: YS, YM, YL	\$59.99

**GEL-TO-SHELL™ TECHNOLOGY:** begins soft and flexible, transforms to hard and protective in minutes

**CUSTOM-MOLDING SHIELD:** molds to user's body shape, ensuring a perfect fit

**IMPACT IS DISPERSED:** not absorbed

**SWEAT-WICKING PERFORMANCE SHIRT:** designed for increased comfort for the male athlete; machine washable

**SHIELD IS HAND WASHABLE:** air dry

**CONTAINS:** 1 custom-molding protective chest shield and 1 sleeveless compression shirt

**FABRIC:** Shirt: 84% Polyester / 16% Spandex



**WOMEN'S RACERBACK CHEST GUARD**

**CSTM-MLD**

		MSRP
WTV1144103	WOMEN'S: S, M, L	\$59.99
WTV1144103	GIRLS: YS, YM, YL	\$59.99

**GEL-TO-SHELL™ TECHNOLOGY:** begins soft and flexible, transforms to hard and protective in minutes

**CUSTOM-MOLDING SHIELD:** molds to user's body shape, ensuring a perfect fit

**IMPACT IS DISPERSED:** not absorbed

**SWEAT-WICKING RACERBACK SHIRT:** designed for increased comfort and support for the female athlete; machine washable

**SHIELD IS HAND WASHABLE:** air dry

**CONTAINS:** 1 custom-molding protective chest shield and 1 sleeveless racerback compression shirt

**FABRIC:** 82% Polyester / 18% Spandex





BLACK



NAVY

ROYAL

RED

WHITE

**NEW EVOCHARGE™  
BATTING GLOVES**

**CSTM-MLD**

		MSRP
WTV4100	ADULT: S, M, L, XL, 2XL	\$59. <sup>99</sup>
WTV4101	YOUTH: YS, YM, YL (BLACK & WHITE ONLY)	\$49. <sup>99</sup>

GEL-TO-SHELL™ TECHNOLOGY: begins soft and flexible, transforms to hard and protective in minutes

CUSTOM-MOLDING SHIELD: molds to user's body shape, ensuring a perfect fit

IMPACT IS DISPERSED: not absorbed

SHEEPSKIN LEATHER PALMS: for better control and feel of the bat

SLEEK MOLDED PULL TAB: to secure supportive wrist strap

**CONTAINS:** 1 pair of batting gloves with 1 custom-molding protective hand shield for lead hand





BACK VIEW



BLACK

**NEW**  
**IMPACT BATTING HELMET**



		MSRP
WTV7100	SENIOR: 6 3/4" - 7 1/2"	\$39.99
WTV7101	JUNIOR: 6 1/4" - 7 1/8"	\$39.99

**RECOMMENDED FOR TRAVEL BALL**  
**LIGHTWEIGHT DUAL-DENSITY PADDING:** wrapped ears for superior comfort  
**PREMIUM RUBBERIZED MATTE FINISH**  
**VENTING SYSTEM:** strategically placed vents keep head cool  
**PRE-MOUNTED HARDWARE:** easy to attach accessories, chin strap or accessories (accessories not included)  
**MEETS NOCSAE STANDARDS**

**CONTAINS:** 1 Evoshield batting helmet



NAVY

RED

ROYAL

WHITE



**NEW**  
**IMPACT FACE MASK & CHINSTRAP**



		MSRP
WTV7310BL	ONE SIZE	\$19.99

**GREAT SIGHT LINES:** design optimized for baseball and softball  
**EASY INSTALL:** facemask hardware included  
**MEETS NOCSAE STANDARDS:** when used with impact batting helmets (compatible with WTV7100, WTV7101, WTV2047430 and WTV2047431)

**CONTAINS:** 1 face mask, 1 chinstrap and hardware



**DEFENDER'S MASK**

		MSRP
WTV2144250	ONE SIZE	\$49.99

**SUPERIOR COMFORT:** customizable cheek and chin pads for custom fit  
**GREAT SIGHT LINES:** streamlined design and low profile padding for increased visibility  
**PRESSURE REDUCING PROTECTION:** 4 points of contact on the user's face for reduced pressure and more effective protection

**CONTAINS:** 1 face mask with 4 pads





OFFICIAL PROTECTIVE GEAR SUPPLIER  
OF MAJOR LEAGUE BASEBALL.  
MAJOR LEAGUE BASEBALL TRADEMARKS AND COPYRIGHTS ARE USED WITH  
PERMISSION OF MAJOR LEAGUE BASEBALL PROPERTIES, INC. VISIT MLB.COM

BATTING HELMETS



# COMPRESSION



**NEW EVOCHARGE™  
COMPRESSION WRIST WITH STRAP**

WTV5300	S, M, L, XL	MSRP \$24.99
---------	-------------	-----------------

COMPRESSION WITHOUT THE HASSLE OF USING TAPE  
 ADJUSTABLE ELASTIC STRAP: for desired compression and wrist support  
 PULL-TAB: with easy-on, easy-off action secures shield for a lock tight hold  
 HAND WASH: air dry

**CONTAINS:** 1 neoprene sleeve with adjustable compression strap  
**FABRIC:** 100% Neoprene



**NEW EVOCHARGE™  
COMPRESSION ARM SLEEVE**

WTV8601	YOUTH, S/M, L/ XL	MSRP \$19.99
---------	-------------------	-----------------

SWEAT-WICKING MATERIAL: to keep you dry and comfortable on the field  
 MACHINE WASHABLE: hang dry

**CONTAINS:** 1 compression arm sleeve  
**FABRIC:** 84% Polyester / 16% Elastane



**NEW  
PLAYCALL WRIST SLEEVE**

WTV5000BL	ONE SIZE	MSRP \$19.99
-----------	----------	-----------------

VIEWING WINDOW: clear plastic pocket for easy access to plays  
 NEOPRENE CONSTRUCTION: supports wrist with compression  
 NO-SLIP FIT: to prevent having to readjust during the game  
 HAND WASH: air dry  
 SLEEVE COVERAGE : 5" L

**CONTAINS:** 1 playcall neoprene wrist sleeve with clear plastic viewing window  
**FABRIC:** 83% Nylon / 17% Spandex



# ACTIVEDNA

STRATEGIC BODY-MAPPED COMPRESSION

## DURING

### INCREASE CIRCULATION & MUSCLE PERFORMANCE WITH ActiveDNA

#### INCREASES O<sub>2</sub> LEVELS

HELPS DELIVER THE OXYGEN MUSCLES NEED TO PERFORM.

#### FLUSHES TOXINS

HELPS REMOVE LACTIC ACID AND OTHER TOXINS TO PROLONG MUSCLE PERFORMANCE.

#### STABILIZES MUSCLES

SUPPORTS MUSCLES TO REDUCE VIBRATIONS THAT CAUSE FATIGUE.

## BEFORE/AFTER

### DECREASE SORENESS & RECOVERY TIME WITH RecoveryDNA

#### DECREASES SWELLING

INCREASES CIRCULATION TO REDUCE SWELLING AND DECREASE BLOOD POOLING.

#### REDUCES SORENESS

HELPS RID THE BODY OF LACTIC ACID AND OTHER TOXINS THAT CAUSE SORENESS.

#### REDUCES RECOVERY TIME

ENHANCES BLOOD FLOW, DELIVERING THE OXYGEN MUSCLES NEED TO RECOVER.

# RECOVERYDNA

STRATEGIC BODY-MAPPED COMPRESSION

COMPRESSION





**ACTIVE DNA COMPRESSION ARM SLEEVE**

WTV1026282	S/M, M/L, L/XL	MSRP \$24.99
------------	----------------	-----------------

STRATEGIC BODY-MAPPED COMPRESSION: for improved muscle performance  
 360° STRETCH FABRIC: for comfort and flexibility  
 MAXIMIZES YOUR MUSCLE PERFORMANCE: minimize in-game arm strain  
 DESIGNED TO BE WORN IN COMPETITION OR DURING PRACTICE  
 HAND WASH: in cold water, air dry

**CONTAINS:** 1 Active Compression arm sleeve  
**FABRIC:** Polyester spandex



**NEW ACTIVE DNA COMPRESSION TIGHTS**

WTV8202	S, M, L, XL, 2XL	MSRP \$99.99
---------	------------------	-----------------

STRATEGIC BODY-MAPPED COMPRESSION: for improved muscle performance  
 360° STRETCH FABRIC: for comfort and flexibility  
 MAXIMIZES YOUR MUSCLE PERFORMANCE: minimize in-game arm strain  
 DESIGNED TO BE WORN IN COMPETITION OR DURING PRACTICE  
 HAND WASH: in cold water, air dry

**CONTAINS:** 1 pair Active Compression tights  
**FABRIC:** Polyester Spandex



**RECOVERY DNA COMPRESSION ARM SLEEVE**

WTV1026182	S/M, M/L, L/XL	MSRP \$29.99
------------	----------------	-----------------

STRATEGIC BODY-MAPPED COMPRESSION: for improved muscle recovery  
 360° STRETCH FABRIC: for comfort and flexibility  
 REDUCES SORENESS: shortens recovery time by enhancing blood flow and flushing toxins  
 DESIGNED FOR POST-GAME WEAR  
 HAND WASH: in cold water, air dry

**CONTAINS:** 1 Recovery Compression arm sleeve  
**FABRIC:** Polyester spandex



**NEW RECOVERY DNA COMPRESSION TIGHTS**

WTV8200	S, M, L, XL, 2XL	MSRP \$139.99
---------	------------------	------------------

STRATEGIC BODY-MAPPED COMPRESSION: for improved muscle recovery  
 360° STRETCH FABRIC: for comfort and flexibility  
 REDUCES SORENESS: shortens recovery time by enhancing blood flow and flushing toxins  
 DESIGNED FOR POST-GAME WEAR  
 HAND WASH: in cold water, air dry

**CONTAINS:** 1 pair Recovery Compression tights  
**FABRIC:** Polyester Spandex



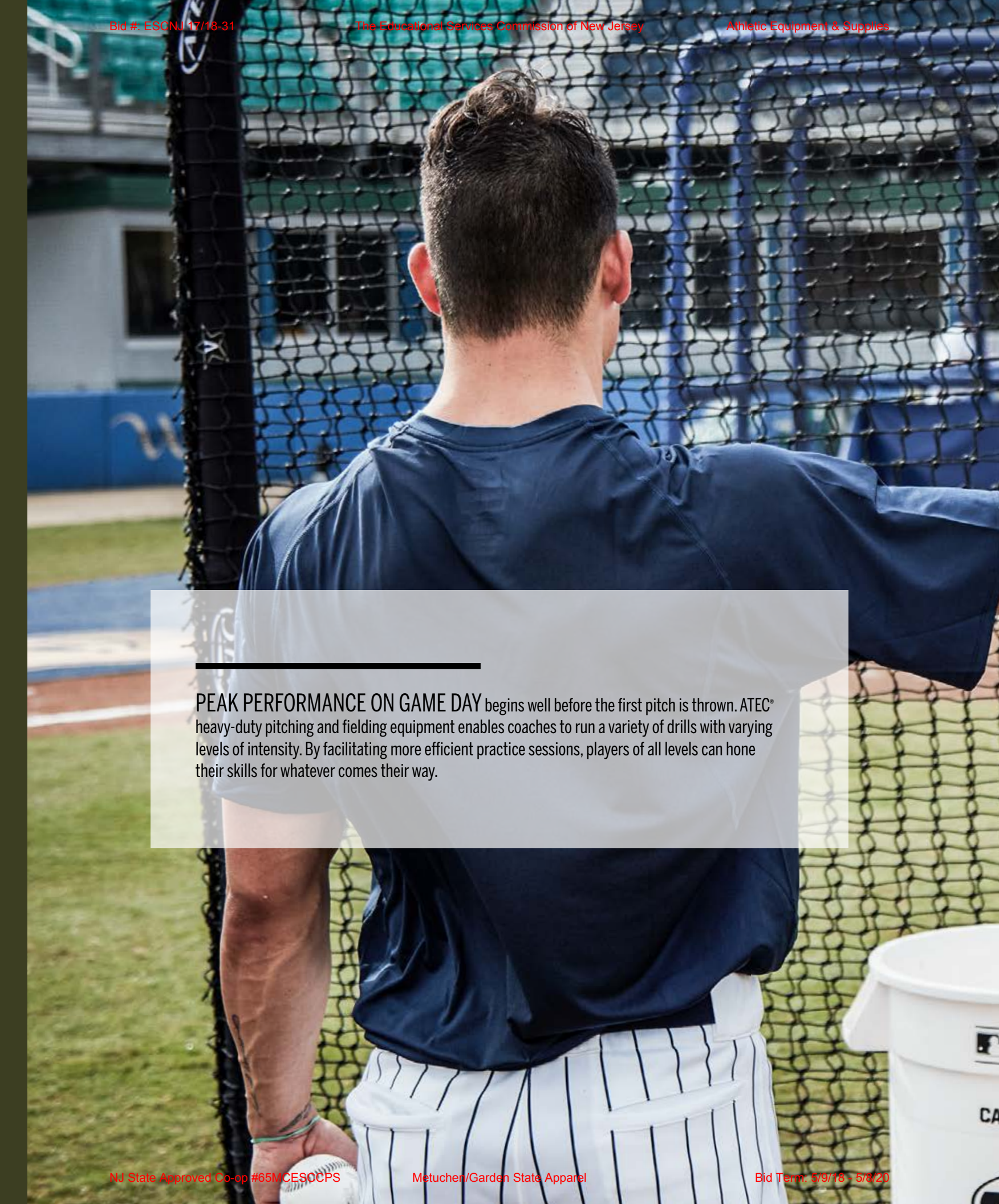

**PEAK PERFORMANCE ON GAME DAY** begins well before the first pitch is thrown. ATEC® heavy-duty pitching and fielding equipment enables coaches to run a variety of drills with varying levels of intensity. By facilitating more efficient practice sessions, players of all levels can hone their skills for whatever comes their way.







# How you **Use** it, is how we **Name** it.

Our products are categorized by **Product Class** and **Training Level**. Each product's name is developed to help you decide which product is best suited for your training needs, ultimately helping you maximize the effectiveness of your training.

## CLASS

		OFFENSIVE MACHINE	DEFENSIVE MACHINE	TRAINING TEE	TRAINING NET
		<b>M</b>	<b>R</b>	<b>T</b>	<b>N</b>
LEVEL	PROFESSIONAL	<b>3</b>	<b>3</b>	<b>3</b>	
	COLLEGIATE	<b>2</b>	<b>2</b>		
	TRAVEL	<b>1</b>			<b>1</b>



# M3™

CLASS: **OFFENSIVE PITCHING MACHINE**

LEVEL: **PROFESSIONAL**



**M3** CLASS: OFFENSE DEFENSE

LEVEL: PROFESSIONAL COLLEGIATE TRAVEL



The M3 Offensive Pitching Machine is built to train professional level ballplayers. Its industry leading 3-wheel design allows for hitters to have complete visibility of the ball throughout the entire pitch cycle, which improves their timing and increases their pitch recognition. By utilizing three concave wheels; top speed, accuracy, and spin are maximized due to the ball's increased surface contact with the wheels. The M3 is equipped to throw 105mph giving you the ability to train against Major League level fastballs and both right and left handed breaking balls. Using the speed control knobs, pitches can easily be dialed-in, helping you improve the efficiency and effectiveness of your batting practice. The M3 is the Official Machine of Major League Baseball.



**QUICK FACTS**

TOP SPEED

**105**  
MPH

PITCHES THROWN

**FB**  
FASTBALL
**CB**  
CURVEBALL
**SL**  
SLIDER
**SP**  
SPLITTER
**KN**  
KNUCKLEBALL

COMPATIBLE BALL TYPES



**PRODUCT FEATURES**

- High Definition Ball Chute**
    - Players have a clear and uninterrupted view of the ball throughout the entire pitch cycle
    - Hitters see when to stride and achieve a live-arm sense of timing for the most realistic repetitions
  - Quick-Pitch-Select**
    - Change quickly between Major League level fastballs and breaking balls using the speed control dials
  - Concave Dual-Durometer Wheels**
    - Increases ball grip to maximize pitch accuracy of both fastballs and breaking balls
    - Faster acceleration than standard wheels, increasing maximum pitch speed and minimizing recovery time
  - Durable Steel Frame**
    - Rugged frame and wide-base tripod absorb machine recoil ensuring maximum accuracy of every pitch
  - ABS Wheel Guards**
    - Helps protect operator and wheels during use
- Real Ball Compatibility**
- Compatible for use with leather baseballs as well as dimpled and foam machine baseballs

**PRODUCT SPECS.**

SPORT	STOCK NO.	BASE	MSRP
BB	WTATMM3BT	Tripod	\$2,899.95

Baseball - M3BT	
Ball Size	Baseball: 9"
Ball Types	Leather, Dimple & Foam
Speed Range	30-105 MPH
Recovery Time	8 SEC
Pitch Height	60 IN
Base Type	Tripod
Footprint	1260 IN²
Weight	125 LBS
Power Supply	110v AC
Generator Use	1800w CD



# M2™

CLASS: **OFFENSIVE PITCHING MACHINE**

LEVEL: **COLLEGIATE**



ATEC OFFENSIVE TRAINING MACHINES

**M2** CLASS: OFFENSE DEFENSE

LEVEL: PROFESSIONAL COLLEGIATE TRAVEL

The M2 Offensive Pitching Machine, formerly called the 'Casey Pro', is built to train collegiate level ballplayers. When it comes to accuracy, power and portability, no other 2-wheel machine is better equipped than the M2. With the ability to pitch 90mph, the M2 can throw collegiate level fastballs, curveballs and sliders to any spot in the strike zone. The M2 is used and trusted by many nationally ranked college programs to develop their elite players and take their hitting abilities to the next level.



**QUICK FACTS**

TOP SPEED

**90**  
MPH

PITCHES THROWN



FASTBALL



CURVEBALL



SLIDER

COMPATIBLE BALL TYPES



LEATHER



DIMPLE



FOAM

**PRODUCT FEATURES**

- 1. Concave A.I.H Wheels**
  - Concave tread increases ball grip to maximize pitch accuracy of both fastballs and breaking balls
- 2. Quick Change Tilt System**
  - Gives you the ability to throw both collegiate level fastballs and right and left handed breaking balls
  - Allows the machine's head to tilt and change the axis of rotation on the pitched ball
- 3. Durable Steel Frame**
  - Rugged frame and wide-base tripod absorb machine recoil ensuring maximum accuracy of every pitch
- 4. Built-in transport wheels**
  - Integrated injection molded wheels promote maximum mobility and ease of storage
- 5. Vertical Micro Adjuster (Add on Feature)**
  - Upgrade M2 machine with vertical micro adjuster, which allows ball pitch location to be adjusted 36" up/down during hitting session while making no major adjustments to the machine set up

**Real Ball Compatibility**

- Compatible for use with leather balls as well as dimpled and foam machine balls

**PRODUCT SPECS.**

SPORT	STOCK NO.	BASE	MSRP
BB	WTATMM2BT	Tripod	\$2,199.95
SB	WTATMM2SL	Lowpod	\$2,199.95
<b>M2 WITH VERTICAL MICRO ADJUSTER</b>			
SPORT	STOCK NO.		MSRP
BB	WTATMM2BT3G		\$2,299.95
SB	WTATMM2SL3G		\$2,299.95

	<b>Baseball - M2BT</b>	<b>Softball - M2SL</b>
Ball Size	Baseball: 9"	Softball: 12"
Ball Types	Leather, Dimple & Foam	Leather, Dimple & Foam
Speed Range	30-90 MPH	30-90 MPH
Recovery Time	8 SEC	8 SEC
Pitch Height	60 IN	25 IN
Base Type	Tripod	Lowpod
Footprint	1260 IN <sup>2</sup>	340 IN <sup>2</sup>
Weight	110 LBS	90 LBS
Power Supply	110v AC	110v AC
Generator Use	1200w CD	1200w CD

M1™

CLASS: **OFFENSIVE PITCHING MACHINE**

LEVEL: **TRAVEL**



LEVEL	M1	CLASS	OFFENSE	DEFENSE
	PROFESSIONAL			
	COLLEGIATE			
TRAVEL				

The M1 is the highest performing and most durable 1-wheel pitching machine. It's built using the same technology, processes and materials as ATEC's other industry leading training machines. Similar to ATEC's professional and collegiate level training machines, the M1 is also equipped with a concave wheel. This wheel is engineered to increase grip on the ball to maximize both pitch speed and accuracy. The M1 is portable and powerful, designed to be the workhorse on the field and in the batting cage. It's capable of throwing fastballs up to 70mph, as well as right and left-handed breaking balls, with any ball type; including real leather balls.



**QUICK FACTS**

<p>TOP SPEED</p> <p style="font-size: 48pt; font-weight: bold;">70 MPH</p>	<p>PITCHES THROWN</p> <div style="display: flex; justify-content: space-around;"> <div style="text-align: center;"> <p style="font-size: 36pt; font-weight: bold;">FB</p> <p>FASTBALL</p> </div> <div style="text-align: center;"> <p style="font-size: 36pt; font-weight: bold;">CB</p> <p>CURVEBALL</p> </div> </div>	<p>COMPATIBLE BALL TYPES</p> <div style="display: flex; justify-content: space-around;"> <div style="text-align: center;">  <p>LEATHER</p> </div> <div style="text-align: center;">  <p>DIMPLE</p> </div> <div style="text-align: center;">  <p>FOAM</p> </div> </div>
--	---	---

**PRODUCT FEATURES**

- Concave Dual-Durometer Wheel**
    - Increases ball grip to maximize pitch accuracy of both fastballs and breaking balls
    - Faster acceleration than standard wheels, increasing maximum pitch speed and minimizing recovery time
  - Quick-Change Tilt System**
    - Gives you the ability to throw both fastballs and right and left hand curveballs
    - Allows the machine's head to tilt and change the axis of rotation on the pitched ball
  - Durable Steel Frame**
    - Rugged frame and wide-base tripod absorb machine recoil ensuring maximum accuracy of every pitch
  - ABS Wheel Guard**
    - Helps protect operator and wheel during use
  - NEW Metal Ball Chute**
    - Durable metal ball chute will protect machine from damage from ball ricochet
- Real Ball Compatibility** Compatible for use with leather balls as well as dimpled and foam machine balls

**PRODUCT SPECS.**

SPORT	STOCK NO.	BASE	MSRP
BB	WTATMM1BT	Tripod	\$1,199.95
SB	WTATMM1SL	Lowpod	\$1,199.95

	Baseball - M1BT	Softball - M1SL
Ball Size	Baseball: 9"	Softball: 12"
Ball Types	Leather, Dimple + Foam	Leather, Dimple + Foam
Speed Range	70 MPH	30-70 MPH
Recovery Time	8 SEC	8 SEC
Pitch Height	62 IN	28 IN
Base Type	Tripod	Lowpod
Footprint	1260 IN <sup>2</sup>	340 IN <sup>2</sup>
Weight	80 LBS	60 LBS
Power Supply	110v AC	110v AC
Generator Use	600w CD	600w CD



# R3™

CLASS: DEFENSIVE TRAINING MACHINE

LEVEL: PROFESSIONAL



ATEC DEFENSIVE TRAINING MACHINES 144

LEVEL	<b>R3</b>	CLASS	OFFENSE	DEFENSE
	PROFESSIONAL			
	COLLEGIATE			
	TRAVEL			

The R3 is used by Major League teams to develop and strengthen their players' defensive skills. Formerly called the **Power Hammer**, the R3 throws 10 balls per minute, giving you the ability to execute hundreds of ground balls, line drives, fly balls and pop-ups in a single practice. Equipped with a recovery time of 6 seconds, the R3 is extremely efficient. Incorporating either of ATEC's R-Series machines into your practice increases the practice's efficiency by eliminating the possibility of errant fungo hits. The R3 is built to perform all Major League level defensive drills; including vertical pop-ups to catchers and sending balls from home plate to the fence to help outfielders improve playing balls at the warning track and off the wall.

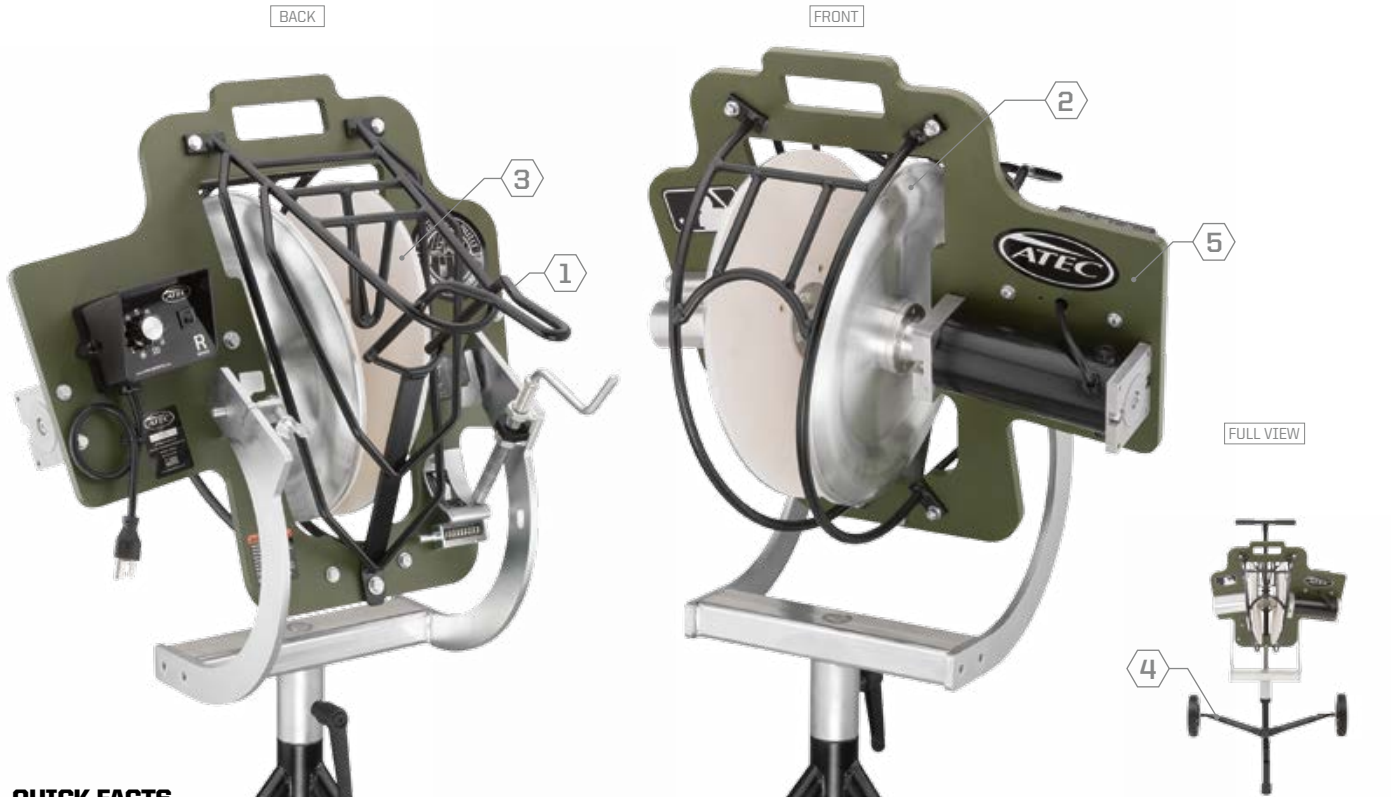

**QUICK FACTS**

TOP SPEED	MAXIMUM FLY BALL	RECOVERY TIME	WEIGHT	COMPATIBLE BALL TYPES
<b>85</b> MPH	<b>340</b> FT	<b>6</b> SEC	<b>115</b> LBS	LEATHER                  DIMPLE                  FOAM

**PRODUCT FEATURES**

- Full Control Fungo System (FCFS)**
    - Maximizes your ability to control exactly where the ball is placed during defensive drills
    - Change the ball placement of each rep, or keep it locked in to maximize repetitions of a single type
  - Hi.Per® Aluminum Discs**
    - Allows the machine to achieve the lowest recovery time possible for maximum repetitions
    - Engineered to be extremely lightweight and durable
  - High Definition Ball Chute**
    - Players have a clear and uninterrupted view of the ball throughout the entire cycle
  - Caddy pod**
    - Industry leading wheeled transport system makes set up and transitioning between drills quick and simple
  - Durable Steel Frame**
    - Rugged frame and caddy pod absorb machine recoil ensuring maximum accuracy of every pitch
- Real Ball Compatibility**
- Compatible for use with leather baseballs as well as dimpled and foam machine baseballs

**PRODUCT SPECS.**

SPORT	STOCK NO.	BASE	MSRP
BB	WTATMR3BC	Caddy pod	\$2,749.95

  

	<b>Baseball-R3BC</b>
Ball Size	Baseball: 9"
Ball Types	Leather, Dimple + Foam
Speed Range	30-85 MPH
Recovery Time	6 SEC
Pitch Height	20 IN
Base Type	Caddy pod
Footprint	900 IN <sup>2</sup>
Weight	115 LBS
Power Supply	110v AC
Generator Use	600w CD

# R2™

CLASS: DEFENSIVE TRAINING MACHINE

LEVEL: COLLEGIATE

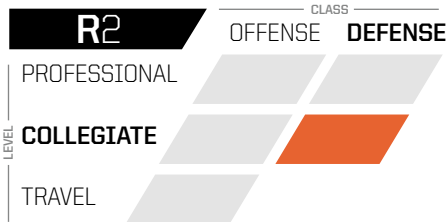
The R2, formerly called the **Rookie**, is built for collegiate level defensive training. It is designed to be a more compact version of the professional level R3 training machine. Both R-Series machines have the unique ability to rotate and pivot freely while the machine is on and in use, allowing you to challenge multiple fielders, playing different positions, one after another. Just like the R3, the R2 also allows you to achieve the maximum number of repetitions for any defensive drill; giving your players more quality repetitions than could possibly be achieved with only a fungo bat.



**QUICK FACTS**

TOP SPEED	MAXIMUM FLY BALL	RECOVERY TIME	WEIGHT	COMPATIBLE BALL TYPES
<b>75</b> MPH	<b>300</b> FT	<b>7</b> SEC	<b>70</b> LBS	 <p>LEATHER      DIMPLE      FOAM</p>

**PRODUCT FEATURES**

- Full Control Fungo System (FCFS)**
    - Maximizes your ability to control exactly where the ball is placed during defensive drills
    - Change the ball placement of each rep, or keep it locked in to maximize repetitions of a single type
  - Hi.Per® Aluminum Discs**
    - Allows the machine to achieve the lowest recovery time possible
    - Engineered to be extremely lightweight and durable
  - High Definition Ball Chute**
    - Players have a clear and uninterrupted view of the ball throughout the entire cycle
  - Caddy pod**
    - Industry leading wheeled transport system makes set up and transitioning between drills quick and simple
  - Durable Steel Frame**
    - Rugged frame and caddy pod absorb machine recoil ensuring maximum accuracy of every pitch
- Real Ball Compatibility**
- Compatible for use with leather balls as well as dimpled and foam machine balls

**PRODUCT SPECS.**

SPORT	STOCK NO.	BASE	MSRP
BB	WTATMR2BC	Caddy pod	\$1,999.95
SB	WTATMR2SC	Caddy pod	\$1,999.95

	Baseball - R2BC	Softball - R2SC
Ball Size	Baseball: 9"	Softball: 12"
Ball Types	Leather, Dimple & Foam	Leather, Dimple & Foam
Speed Range	75 MPH	70 MPH
Recovery Time	7 SEC	7 SEC
Pitch Height	20 IN	20 IN
Base Type	Caddy pod	Caddy pod
Footprint	900 IN <sup>2</sup>	900 IN <sup>2</sup>
Weight	70 LBS	70 LBS
Power Supply	110v AC	110v AC
Generator Use	600w CD	600w CD

# BUCKET FEEDER



The Bucket Feeder is designed for use with any current ATEC machine, as well as many older generation models. Compatible with a five or six gallon bucket, the Bucket Feeder is designed to reduce time spent between shagging balls and resuming the current training session. Perfect for coaches looking for a hands off approach for machine operation, allowing better focus on player development; or players looking for a solo training solution.



## QUICK FACTS

FEEDER RELOAD TIME	MAX BALL CAPACITY	PITCH INTERVAL
<b>30</b> SEC	<b>60</b> BASEBALLS	<b>8</b> SEC

## COMPATIBLE BALL TYPES



## PRODUCT FEATURES

- Easy Load Design**
    - Pivoting Head allows for upright bucket loading
    - Reload Feeder with new bucket in under 30 seconds
  - Compatible with five or six gallon buckets**
    - Five Gallon = 48 Baseballs
    - Six Gallon = 60 Baseballs
- Compatible with Wireless Feeder Remote (sold separately)**
- Control the on/off of the feeder, or use as a pause for mid-training instruction
  - 50ft Range
- Compatible with the following ATEC machines:**
- M3, M2, M1
  - R2 (on Tripod)
  - Casey Pro 3G, Casey Pro
  - Power Hummer, Rookie
  - Axis, Radius

## PRODUCT SPECS.

STOCK NO.	MODEL	MSRP
WTATAMFBK	Bucket Feeder	\$799.95

## ALTERNATE VIEW





# TRAINING BALLS



Machines are only one part of what creates consistent and accurate ball flight. The balls you choose to use with your machine are the second most important factor in your training machine's accuracy, and account for roughly 30% of the accuracy equation. Our High Performance (Hi.Per®) ball line is built with numerous proprietary aerodynamic designs that maximize your training machine's accuracy. Each ball within the Hi.Per lineup is the most advanced ball in its class, helping you achieve the most consistent and accurate ball flight every time.



## Hi.Per® Pro – Leather Flat Seam Ball

(Built for Real Ball Training)

Regulation Size & Weight • Premium Full Grain Leather Cover • High-Tensile Strength AccuSeams made from Heavy-Duty Kevlar • Red Cushion Cork Center (Baseball) • Polycore Center Max. 44 COR (Softball) • Safe for use with Performance Bats • Approved for Indoor & Outdoor Training

BASEBALL		MSRP	SOFTBALL [12"]		MSRP
WTATBL01B12	1 Dozen	\$69.95	WTATBL02S12	1 Dozen	\$99.95
WTATBL01B24	2 Dozen & Ball Bucket	\$139.95	WTATBL02S24	2 Dozen & Ball Bucket	\$199.95
WTATBL01B36	3 Dozen & Ball Bucket	\$209.95	WTATBL02S36	3 Dozen & Cage Bucket	\$299.95



## Hi.Per® X-ACT – Dimple Ball

(Built for Maximum Machine Accuracy)

Regulation Size & Weight • Sting Blocking Construction • Xtream Aerodynamic Technology (X-ACT) Surface Design Maximizes Training Machine Accuracy • Safe for use with Performance Bats • Approved for Indoor & Outdoor Training

BASEBALL		MSRP	SOFTBALL [12"]		MSRP
WTATBD02B12	1 Dozen	\$49.95	WTATBD02S12	1 Dozen	\$59.95
WTATBD02B24	2 Dozen & Ball Bucket	\$99.95	WTATBD02S24	2 Dozen & Ball Bucket	\$119.95
WTATBD02B36	3 Dozen & Ball Bucket	\$149.95	WTATBD02S36	3 Dozen & Cage Bucket	\$179.95



## Hi.Per® Lite – Foam Ball

(Built for High Repetition Training)

Regulation Size • ~30% Regulation Weight • Durable High-Density Foam Construction • Aerodynamically Optimized Surface Design Maximizes Training Machine Accuracy • Safe for use with Performance Bats • Approved for Indoor & Outdoor Training

BASEBALL		MSRP	SOFTBALL [12"]		MSRP
WTATBF02B12	1 Dozen	\$39.95	WTATBF02S12	1 Dozen	\$49.95
WTATBF02B24	2 Dozen & Ball Bucket	\$79.95	WTATBF02S24	2 Dozen & Ball Bucket	\$99.95
WTATBF02B36	3 Dozen & Ball Bucket	\$119.95	WTATBF02S36	3 Dozen & Cage Bucket	\$149.95



## Hi.Per® LTD – Limited Distance Ball

(Built for Limited Space Training)



Regulation Size • Perfect for Pre-Game Warm Up • Maximum Flight Distance of ~100ft • XDC (Xtra Durable Composite) Construction Eliminates Cracking • Proprietary Tactile Surface Texture Increases Grip & Throwing Accuracy • Approved for Indoor & Outdoor Training

BASEBALL		MSRP
WTATBP02B04	4 Pack (Sold in Retail Packaging)	\$19.95
WTATBP02B12	1 Dozen	\$39.95
WTATBP02B24	2 Dozen & Ball Bucket	\$79.95
WTATBP02B36	3 Dozen & Ball Bucket	\$119.95



## Hi.Per® POWER – Weighted Training Ball

(Built for Limited Space Training)



Regulation Size • 2.5x the Weight of Regulation Baseball • Perfect for Pre-Game Warm Up • Maximum Flight Distance of ~50ft • XDC (Xtra Durable Composite) Construction Eliminates Cracking • Approved for Indoor & Outdoor training • Not for Machine Use

BASEBALL		MSRP
WTATBW02B4	4 Pack (Sold in Retail Packaging)	\$39.95



## Buckets

### Ball Bucket

Baseball Capacity: **4 DZ**/ Softball Capacity: **2 DZ**  
Closed-Cell Foam Cushioned Lid • Durable Padded Handle • Semitransparent Color • 5 Gallon Volume

### Cage Bucket

Baseball Capacity: **8 DZ**/ Softball Capacity: **3 DZ**  
Rugged Built-In Handles for Maximum Durability • White Color • 9.5 Gallon Volume

BASEBALL		MSRP
WTATABBKT	Ball Bucket	\$24.95
WTATACBKT	Cage Bucket	\$49.95

# PRO BATTING TEES



**T3™ & T3 SHORTY:** Players use batting tees every, single, day. It is the most important piece of training equipment and our T3 tees are a staple in every Major League batting tunnel. The T3 is precisely engineered and built with industry leading materials to minimize swing interference and maximize positive contact zone feedback. The T3 lineup is designed to exceed the expectations of MLB® players and coaches. Our professional tees come with a full 1-year warranty and can quickly be set up and taken down for maximum portability.

**T3™ TEE WEIGHT:** An eight pound vinyl coated steel weight that will fit on all existing T3 Tee models. Custom fit, snug on the base of the tee stem, adding stability to the tee, while minimizing rattle and damage to the tee stem that can be caused when using a weighted plate from a gym or weight room. This tee weight is removable from the tee stem and easily stored when not in use.



**QUICK FACTS**

	MAXIMUM HEIGHT	MINIMUM HEIGHT		MAXIMUM HEIGHT	MINIMUM HEIGHT	
T3	<b>43</b> IN	<b>23</b> IN		T3s	<b>22</b> IN	<b>16</b> IN

**PRODUCT FEATURES**

- Hi.Per® Composite Cone**
    - Helically-wrapped proprietary high performance composite minimizes swing interference and maximizes durability
    - Minimal swing interference provides optimal feedback to the hitter on every swing
  - CNC Aluminum Stem**
    - Precision-milled and weather resistant aluminum maximizes performance and durability
    - Patented internal construction creates maximum friction between tiers allowing the height of the tee to remain consistent after every swing
    - Ball height can quickly be adjusted enabling the hitter to practice their mechanics on pitch heights throughout the strike zone
  - High Density Base**
    - High density material maximizes tee stability and durability
    - Easily removed from the stem for easy portability
- T3 Tee Weight**
- Compatible with both T3 & T3 Shorty batting tees
  - Custom fit to T3 base to reduce vibration during use
  - Heavy Duty Steel Construction
  - Portable and Easy to Install

**PRODUCT SPECS.**

STOCK NO.	MODEL	MSRP
WTATT3000	T3*	\$99.95
WTATT3500	T3s	\$89.95
WTATT3BWT	T3 Base Weight	\$29.95

**T3 PROFESSIONAL BATTING TEES**

- Supplied to all 30 Major League Teams

\*Sold in Retail Packaging

# TUFFY® TEE



The weighted base design provides maximum stability while allowing the batter to move the tee anywhere in their swing range. Adjustable stem and insert are designed for all heights and areas of the strike zone. Tuffy® Tees come with a 5-year limited warranty, so this tee is built to take a beating, season after season.



### QUICK FACTS

TUFFY	MAXIMUM HEIGHT	MINIMUM HEIGHT	
	<b>40</b> IN	<b>22</b> IN	

### PRODUCT FEATURES

- Extremely Durable Cast Polyurethane**
  - Perfect for any age/ability
  - Able to withstand mis-hits as well as high repetition, high velocity swings
- Built in Steel Plate in Tee Base Reduces Tee movement**
  - Eliminates picking the tee up off the ground after mis-hits
- NEW Upgraded Ball Stem**
  - New design eliminates drag through impact, as well as reduces bat vibration on mis-hits
- Optional Brush Tee & Adapter**
  - Reduced resistance results in accurate ball flight for training
  - Adapter to fit most tube-style tees included

### PRODUCT SPECS.

STOCK NO.	MODEL	MSRP
WTAT7375	Tuffy Tee	\$149.95
WTAT0255	Brush Tee & Adapter	\$19.95





# PROTECTIVE SCREENS



Padded L Screen

Padded 1B Screen



Padded SB Screen

Padded BP Screen



Wheel Kit



## PADDED PROTECTIVE SCREENS

STOCK NO.	PRODUCT	MSRP
WTAT75300LSC	Padded L Screen	\$499.95
WTAT754001BSC	Padded 1B Screen	\$499.95
WTAT75600SBSC	Padded SB Screen	\$499.95
WTAT20600BPSC	Padded BP Screen	\$499.95
WTAT1395	Wheel Kit	\$74.95

Padding Deflects Balls and Increases Durability • Steel Tubing Under Padding • Commercial Grade Weather Resistant Netting • Compatible with Optional Wheel Kit • 2 Year Limited Warranty



L Screen

1B Screen



SB Screen

BP Screen



Wheel Kit



## PROTECTIVE SCREENS

STOCK NO.	PRODUCT	MSRP
WTAT7532	L Screen	\$299.95
WTAT7542	1B Screen	\$299.95
WTAT7562	SB Screen	\$299.95
WTAT2061	BP Screen	\$299.95
WTAT1395	Wheel Kit	\$74.95

Steel Tubing • Commercial Grade Weather Resistant Netting • Compatible with Optional Wheel Kit • 1 Year Limited Warranty

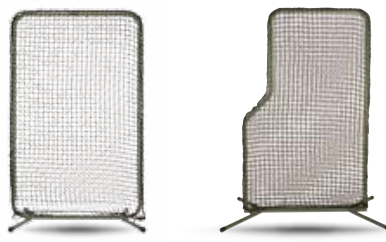

R Screen

Portable L Screen



## LOW PROFILE PROTECTIVE SCREENS

STOCK NO.	PRODUCT	MSRP
WTAT75500	R Screen	\$224.95
WTAT7440	Portable L Screen	\$224.95

Steel Tubing • Weather Resistant Netting • **Not Intended for Commercial Use** • 1 Year Limited Warranty

## REPLACEMENT NETS

STOCK NO.	PRODUCT	MSRP
WTAT7533	Replacement Net-L-Screen	\$124.95
WTAT7543	Replacement Net-1st Base Screen	\$124.95
WTAT2062	Replacement Net-BP Screen	\$149.95
WTAT3418	Replacement Net- Portable L-Screen	\$84.95



# CUSTOM PADDED PROTECTIVE SCREENS



## 1. Choose your screen style



Padded L Screen

Padded 1B Screen



Padded SB Screen

Padded BP Screen

## 2. Select Spandex sleeve color

## 3. Select ATEC® logo color

Sleeve and ATEC logo color options



## 4. Add team logo or team name

## 5. Email order to [customorders@wilson.com](mailto:customorders@wilson.com)

### CUSTOM PADDED PROTECTIVE SCREENS\*

STOCK NO.	PRODUCT	MSRP
WTAT75300LSC	Padded L Screen	\$599.95
WTAT754001BSC	Padded 1st Base Screen	\$599.95
WTAT75600SBSC	Padded Softball Screen	\$599.95
WTAT20600BPSC	Padded BP Screen w/ Ball Sock	\$599.95

Padding Deflects Balls and Increases Durability • Steel Tubing Under Padding • Commercial Grade Weather Resistant Netting • Compatible with Optional Wheel Kit • 2 Year Limited Warranty

\*ATEC screens subject to availability

\*Please allow for 20-25 business days for sublimated sleeve to be complete

\*Logos and text will be fit to scale

# TRAINING NETS



## N1™ PORTABLE PRACTICE NET

STOCK NO.	PRODUCT	MSRP
WTATN1000	N1	\$149.95

Industry leading and proprietary angled design eliminates ball rebound and minimizes ball collection time • Utilizes durable knotted nylon netting with steel and fiberglass frame • Extremely stable in outdoor elements • Sets up in less than 2 minutes • Includes premium carrying bag • Great for both hitting and pitching drills • 1 year limited warranty

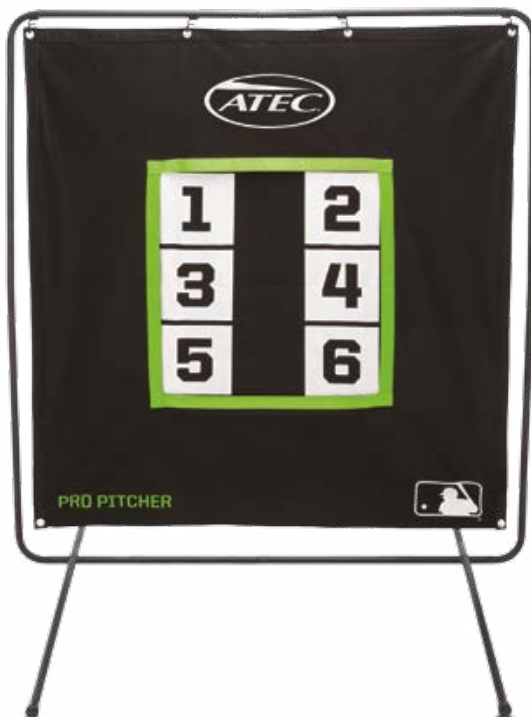

## PRO PITCHER

STOCK NO.	PRODUCT	MSRP
WTATNPP00	Pro Pitcher	\$149.95
WTATPP00P1	Replacement Screen (Screen Only)	\$79.95

Highly visible numbered targets • Increases pitcher's focus and location discipline • Built-in strike zone collection pocket • Heavy duty nylon screen • Steel frame with powder-coated finish • 1 year limited warranty



# ACCESSORIES & PARTS



## CADDYPOD (BATTED BALL HEIGHT & INCREASED MOBILITY)

STOCK NO.	PRODUCT	WEIGHT	FOOTPRINT	MSRP
WTATAMBCP	CaddyPod	25 LBS.	900 IN <sup>2</sup>	\$399.95

Simulates batted ball height • Built in wheels allow for easy transportation and storage • Included with all new R-Series baseball and softball machines • Can be used with any M-Series or R-Series machine



Adult Configuration



Youth Configuration

## TRIPOD (BASEBALL PITCHER RELEASE HEIGHT)

STOCK NO.	PRODUCT	WEIGHT	FOOTPRINT	MSRP
WTATAMBTB	Tripod	30 LBS.	1260 IN <sup>2</sup>	\$299.95

Simulates baseball pitcher's release point • Included with all new M-Series baseball machines • Can be configured to achieve either an adult or youth pitch height • Can be used with any M-Series or R-Series machine



## LOWPOD (SOFTBALL PITCHER RELEASE HEIGHT)

STOCK NO.	PRODUCT	WEIGHT	FOOTPRINT	MSRP
WTATAMBLP	Lowpod	10 LBS.	340 IN <sup>2</sup>	\$199.95

Simulates softball pitcher's release point • Included with all new M-Series softball machines • Can be used with any M-Series or R-Series machine



## MACHINE COVER

STOCK NO.	PRODUCT	MSRP
WTATAMUCR	Machine Cover	\$69.95

Durable water-resistant nylon with drawstring cord • Helps protect machine from the elements • Fits all ATEC Training Machines



## WIRELESS REMOTE (BASEBALLS ONLY)

STOCK NO.	PRODUCT	CAPACITY	MSRP
WTAT0441	Wireless Remote	50'	\$69.95

Feeder remote has a 50' range • Compatible with current bucket feeder, M2 15 & 20 Ball Feeder, and Casey Pro 3G 15 & 20 Ball Feeder

**FOR ALL MACHINE REPLACEMENT PARTS CALL:  
1.800.755.5100**

---

Whether in the midst of the action, or supporting from the sidelines, the right uniforms and apparel are a must when showing your team spirit. Whatever you need, make Wilson your go-to on game day.



# STOCK UNIFORMS

BASEBALL & FASTPITCH





**BASEBALL**

# T100

FULL BUTTON FRONT WITH CURVED APRON BOTTOM

MEN'S SIZES  
**S-2X**  
YOUTH SIZES  
**S-L**

**Shown With:**

- ♦ **WTL4982:** 2-color Script Film Transfer lettering with tail
- ♦ **WTL4982:** 1-color Full Block Film Transfer lettering in tail
- ♦ **WT4957:** 2-color Full Block Film Transfer numerals on front
- ♦ **WT4958:** 2-color Full Block Film Transfer numerals on back
- ♦ **WT4307:** 1 row piping on sleeve ends
- ♦ **WT4313:** 1 row piping around neck and down front



**FULL BODY BREATHABILITY**

**PRICE AS SHOWN**  
\$69<sup>60</sup>

**JERSEY FEATURES:**

- ♦ 100% Polyester Pin Dot
- ♦ Perfect jersey to add braid or piping decoration
- ♦ Buttons spaced to accommodate 4" lettering
- ♦ Lightweight moisture wicking antimicrobial fabric

MEN	MSRP	YOUTH	MSRP
WTD2300	\$35 <sup>00</sup>	WTD3300	\$30 <sup>00</sup>



**AVAILABLE DECORATION:**

- TACKLE TWILL
- SUBLIMATED TWILL
- FILM TRANSFER



**PIPING AVAILABLE AT ADDITIONAL COST**

# S202

PLACKET PULLOVER WITH SET-IN SLEEVES AND CONTRASTING INSERTS

MEN'S SIZES  
**S-2X**  
YOUTH SIZES  
**S-L**

**Shown With:**

- ♦ **WTL4954:** 2-color custom lettering
- ♦ **WTL4925:** 2-color Vegas screen print numerals on front
- ♦ **WTL4925:** 2-color Vegas screen print numerals on back



**NEW**

- AVAILABLE DECORATION:**
- SCREEN PRINTING
  - FILM TRANSFER



Back detail

**PRICE AS SHOWN**  
\$58<sup>00</sup>

**JERSEY FEATURES:**

- ♦ 100% Polyester Double Bar Mesh
- ♦ Contrasting inserts on rear shoulder, neck and sleeve ends
- ♦ Lightweight moisture wicking fabric

MEN	MSRP	YOUTH	MSRP
WTA1207	\$28 <sup>00</sup>	WTA2207	\$24 <sup>00</sup>



# S200

2-BUTTON PLACKET PULLOVER WITH RELAXED FIT & RAGLAN SLEEVES, WITH WHITE PIPING ALONG FRONT SLEEVES/NECK

MEN'S SIZES  
**S-2X**  
YOUTH SIZES  
**S-L**

**Shown With:**

- ♦ **WTL4954:** 2-color Full Block screen print lettering
- ♦ **WTL4921:** 1-color Full Block screen print numeral on front
- ♦ **WTL4925:** 2-color Full Block screen print numeral on back



Side detail

- AVAILABLE DECORATION:**
- SCREEN PRINTING
  - FILM TRANSFER

**PRICE AS SHOWN**  
\$57<sup>00</sup>

**JERSEY FEATURES:**

- ♦ 100% Polyester Double Bar Mesh
- ♦ Breathable contrast side inserts
- ♦ White/Grey side inserts pair with white or grey pants (all white insert on charcoal)
- ♦ Lightweight moisture wicking fabric

MEN	MSRP	YOUTH	MSRP
WTA8521	\$28 <sup>00</sup>	WTA8521	\$24 <sup>00</sup>



# U201

2-BUTTON PLACKET PULLOVER WITH RELAXED FIT & SET-IN SLEEVES, WITH CONTRASTING MESH SIDE INSERTS



MEN'S SIZES  
**S-2X**  
YOUTH SIZES  
**S-L**

## CHOOSE YOUR BRAND ON A STOCK JERSEY

**Shown With:**

- **WTL4954:** 2-color Billings screen print lettering
- **WTL4925:** 2-color Vortex screen print numeral on front
- **WTL4925:** 2-color Vortex screen print numeral on back



**PRICE AS SHOWN**  
\$60<sup>00</sup>

**JERSEYS FEATURE:**

- 100% Polyester Double Bar Mesh
- Breathable contrast Pin Dot mesh side inserts
- Lightweight moisture wicking fabric

**WILSON**

MEN	MSRP	YOUTH	MSRP
WTA2411	\$30 <sup>00</sup>	WTA3411	\$26 <sup>00</sup>

**DEMARINI**

MEN	MSRP	YOUTH	MSRP
WTD2411	\$30 <sup>00</sup>	WTD3411	\$26 <sup>00</sup>

**LOUISVILLE SLUGGER**

MEN	MSRP	YOUTH	MSRP
WTL2411	\$30 <sup>00</sup>	WTL3411	\$26 <sup>00</sup>

**Shown With:**

- **WTL4954:** 2-color Full Block screen print lettering
- **WTL4925:** 2-color Pro Block screen print numeral on front
- **WTL4925:** 2-color Pro Block screen print numeral on back



**PRICE AS SHOWN**  
\$60<sup>00</sup>



**Shown With:**

- **WTL4954:** 2-color Vegas screen print lettering
- **WTL4925:** 2-color Vegas screen print numeral on front
- **WTL4925:** 2-color Vegas screen print numeral on back



**PRICE AS SHOWN**  
\$60<sup>00</sup>



Side detail

**SIDE INSERT BREATHABILITY**

- AVAILABLE DECORATION:**
- SCREEN PRINTING
  - FILM TRANSFER

**BASEBALL**

# GAME DAY™ ATHLETIC FIT PULLOVER JERSEY

MEN'S SIZES  
**S-2X**  
YOUTH SIZES  
**S-L**

**Shown With:**

- ♦ **WTL4954:** 2-color New England screen print lettering
- ♦ **WTL4925:** 2-color Times Bold screen print numeral on front
- ♦ **WTL4925:** 2-color Times Bold screen print numeral on back



**SIDE INSERT BREATHABILITY**

**PRICE AS SHOWN**  
\$56<sup>99</sup>

**JERSEY FEATURES:**

- ♦ 91% Polyester / 9% Spandex
- ♦ 4-way stretch performance top
- ♦ Can be worn as a jersey, workout shirt, or under a jersey
- ♦ Contrast inserts
- ♦ Lightweight moisture wicking and antimicrobial fabric

MEN	MSRP	YOUTH	MSRP
WTD9701	\$26 <sup>99</sup>	WTD9801	\$22 <sup>99</sup>



**AVAILABLE DECORATION:**

- SCREEN PRINTING
- FILM TRANSFER

# S303 PERFORMANCE V-NECK TECH TEE

ADULT SIZES  
**S-2X**  
YOUTH SIZES  
**S-L**

**Shown With:**

- ♦ **WTL4954:** 2-color custom screen print lettering
- ♦ **WTL4925:** 2-color Times Bold screen print numerals on front
- ♦ **WTL4925:** 2-color Times Bold screen print numerals on back



**NEW**

**AVAILABLE DECORATION:**  
• SCREEN PRINTING  
• FILM TRANSFER

**PRICE AS SHOWN**  
\$45<sup>00</sup>

**JERSEY FEATURES:**

- ♦ 100% Polyester Interlock
- ♦ V-neck construction
- ♦ Contrasting inner neck and sleeve ends
- ♦ Can be worn as a jersey, workout shirt, or under a jersey
- ♦ Lightweight moisture wicking antimicrobial fabric

ADULT	MSRP	YOUTH	MSRP
WTA1107	\$15 <sup>00</sup>	WTA2107	\$14 <sup>00</sup>



# S302 PERFORMANCE PULLOVER TECH TEE

MEN'S SIZES  
**S-2X**  
YOUTH SIZES  
**S-L**

**Shown With:**

- ♦ **WTL4954:** 2-color New England screen print lettering
- ♦ **WTL4925:** 2-color SF Shadow screen print numerals on front
- ♦ **WTL4925:** 2-color SF Shadow screen print numerals on back



**AVAILABLE DECORATION:**  
• SCREEN PRINTING  
• FILM TRANSFER

**PRICE AS SHOWN**  
\$43<sup>00</sup>

**JERSEY FEATURES:**

- ♦ 100% Polyester Interlock
- ♦ Can be worn as a jersey, workout shirt, or under a jersey
- ♦ Lightweight moisture wicking antimicrobial fabric

ADULT	MSRP	YOUTH	MSRP
WTA1106	\$11 <sup>00</sup>	WTA2106	\$10 <sup>00</sup>





# T200 COMOTION™ 2-BUTTON HENLEY WITH MESH INSERTS

MEN'S SIZES  
**S-2X**  
YOUTH SIZES  
**S-L**

**Shown With:**

- ◆ **WTL4954:** 2-color Brush Script screen print lettering with tail
- ◆ **WTL4925:** 2-color Full Block screen print numeral on back

**PRICE AS SHOWN**  
\$45<sup>00</sup>



**AVAILABLE DECORATION:**  
• SCREEN PRINTING  
• FILM TRANSFER

**JERSEY FEATURES:**

- ◆ 92% Polyester / 8% Spandex Jersey Knit
- ◆ 4-way stretch fabric to maximize players range of motion
- ◆ Mesh inserts for strategic venting
- ◆ Lightweight moisture wicking antimicrobial fabric

MEN	MSRP	YOUTH	MSRP
WTD2400	\$25 <sup>00</sup>	WTD3400	\$21 <sup>00</sup>



# S201 2-BUTTON PLACKET PULLOVER WITH DIAGONAL WHITE PIPING

MEN'S SIZES  
**S-2X**  
YOUTH SIZES  
**S-L**

**Shown With:**

- ◆ **WTL4954:** 2-color Brush Script screen print lettering with custom tail
- ◆ **WTL4925:** 2-color Full Block screen print numeral on back

**PRICE AS SHOWN**  
\$40<sup>00</sup>



**AVAILABLE DECORATION:**  
• SCREEN PRINTING  
• FILM TRANSFER

**JERSEY FEATURES:**

- ◆ 100% Polyester Rib Back Mesh
- ◆ Breathable material ideal for warm weather climates
- ◆ Comfortable, lightweight moisture wicking fabric

MEN	MSRP	YOUTH	MSRP
WTA8505	\$20 <sup>00</sup>	WTA8505	\$18 <sup>00</sup>



**BASEBALL**

# P300

MEN'S SIZES  
**S-2X**  
YOUTH SIZES  
**S-XL**

**PANT FEATURES:**

- ◆ 100% polyester PRO T3™ 9 oz. warp knit fabric
- ◆ Premium relaxed fit
- ◆ 2 set-in back pockets and ribbed gripper elastic waistband
- ◆ 1" hemmed open bottom
- ◆ Moisture wicking and antimicrobial



ADULT:  
**33" INSEAM**  
YOUTH:  
**GRADUATED INSEAMS**

COLOR	MEN	MSRP	YOUTH	MSRP
BG	WTA4440 GREY	\$44 <sup>00</sup>	WTA424000GR00	\$36 <sup>00</sup>
TW	WTA4440TW	\$44 <sup>00</sup>	WTA4240TW	\$36 <sup>00</sup>

# P301

MEN'S SIZES  
**S-2X**

**PANT FEATURES:**

- ◆ 100% polyester PRO T3™ 9 oz. warp knit fabric
- ◆ Premium classic fit
- ◆ 2 set-in back pockets and ribbed gripper elastic waistband
- ◆ Elastic bottom
- ◆ Moisture wicking and antimicrobial



ADULT:  
**31" INSEAM**

COLOR	MEN	MSRP
BG	WTA4410 GREY	\$35 <sup>00</sup>
TW	WTA4410TW	\$35 <sup>00</sup>

# P200

**PIPED**

MEN'S SIZES  
**S-2X**  
YOUTH SIZES  
**S-XL**

**PANT FEATURES:**

- ◆ 100% polyester PRO T3™ 9 oz. warp knit fabric
- ◆ Relaxed fit
- ◆ Piped
- ◆ 2 set-in back pockets and elastic waistband
- ◆ Open bottom
- ◆ Moisture wicking



**BLUE GREY PANTS**



**WHITE PANTS**

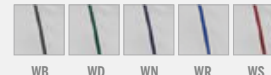

ADULT:  
**GRADUATED INSEAMS**  
YOUTH:  
**GRADUATED INSEAMS**

COLOR	MEN	MSRP	YOUTH	MSRP
Blue Grey	WTA4332GB	\$25 <sup>00</sup>	WTA4232GB	\$21 <sup>00</sup>
Blue Grey	WTA4332GD	\$25 <sup>00</sup>	WTA4232GD	\$21 <sup>00</sup>
Blue Grey	WTA4332GN	\$25 <sup>00</sup>	WTA4232GN	\$21 <sup>00</sup>
Blue Grey	WTA4332GR	\$25 <sup>00</sup>	WTA4232GR	\$21 <sup>00</sup>
Blue Grey	WTA4332GS	\$25 <sup>00</sup>	WTA4232GS	\$21 <sup>00</sup>
White	WTA4332WB	\$25 <sup>00</sup>	WTA4232WB	\$21 <sup>00</sup>
White	WTA4332WD	\$25 <sup>00</sup>	WTA4232WD	\$21 <sup>00</sup>
White	WTA4332WN	\$25 <sup>00</sup>	WTA4232WN	\$21 <sup>00</sup>
White	WTA4332WR	\$25 <sup>00</sup>	WTA4232WR	\$21 <sup>00</sup>
White	WTA4332WS	\$25 <sup>00</sup>	WTA4232WS	\$21 <sup>00</sup>

**ADULT GRADUATED INSEAMS**

W	WTA433000 WTA4332
SIZE	INSEAM
S	31"
M	32"
L	33"
XL	33"
2X	33"

**YOUTH GRADUATED INSEAMS**

W	WTA424000 WTA423000 WTA4232	WTA4228	WTA4204
SIZE	INSEAM	INSEAM	INSEAM
XS	22"	17"	15"
S	23"	18"	16"
M	24"	19"	17"
L	25"	20"	18"
XL	26"	21"	19"
2X	27"	22"	-

# P200

MEN'S SIZES  
**S-2X**  
YOUTH SIZES  
**XS-2X**

**PANT FEATURES:**

- 100% polyester 6 oz. warp knit fabric
- Relaxed fit
- 2 set-in back pockets and elastic waistband
- Open bottom
- Moisture wicking



ADULT:  
**GRADUATED  
INSEAMS**  
YOUTH:  
**GRADUATED  
INSEAMS**

COLOR	MEN	MSRP	YOUTH	MSRP
BG	WTA433000GROO	\$24 <sup>00</sup>	WTA423000GROO	\$20 <sup>00</sup>
WH	WTA433000WHOO	\$24 <sup>00</sup>	WTA423000WHOO	\$20 <sup>00</sup>

# P201

MEN'S SIZES  
**S-2X**  
YOUTH SIZES  
**XS-2X**

**PANT FEATURES:**

- 100% polyester 6 oz. warp knit fabric
- Classic fit
- 2 set-in back pockets (adult)
- 1 set-in back pocket (youth)
- Elastic waistband, elastic bottom
- Moisture wicking



ADULT:  
**28" INSEAM  
YOUTH:  
GRADUATED  
INSEAMS**

COLOR	MEN	MSRP	YOUTH	MSRP
BL	WTA4328 BLA	\$21 <sup>00</sup>	WTA4228 BLA	\$18 <sup>00</sup>
BG	WTA4328 GREY	\$21 <sup>00</sup>	WTA4228 GREY	\$18 <sup>00</sup>
WH	WTA4328 WHI	\$21 <sup>00</sup>	WTA4228 WHI	\$18 <sup>00</sup>

# P100

MEN'S SIZES  
**S-2X**  
YOUTH SIZES  
**XS-XL**

**PANT FEATURES:**

- 100% polyester 5 oz. doubleknit fabric
- Classic fit
- 1 set-in back pocket
- Gathered elastic waistband
- Elastic bottom
- Moisture wicking



ADULT:  
**24" INSEAM  
YOUTH:  
GRADUATED  
INSEAMS**

COLOR	MEN	MSRP	YOUTH	MSRP
BL	WTA4374 BLA	\$16 <sup>50</sup>	WTA4204 BLA	\$10 <sup>50</sup>
BG	WTA4374 GREY	\$16 <sup>50</sup>	WTA4204 GREY	\$10 <sup>50</sup>
WH	WTA4374 WHI	\$16 <sup>50</sup>	WTA4204 WHI	\$10 <sup>50</sup>



**BASEBALL**

**UPRISING™** MEN'S SIZES S-2X YOUTH SIZES S-XL

**PANT FEATURES:**

- 100% Polyester doubleknit (8 oz.)
- Relaxed fit
- Two set in back pockets
- Loose boot cut fit with hemmed open leg bottoms
- Double layered knees
- Double snap closure
- DeMarini Wordmark gripper elastic waistband
- Moisture wicking fabric



PIPING AVAILABLE \$8.60



ADULT: GRADUATED INSEAMS  
YOUTH: GRADUATED INSEAMS

OPTION	MEN	MSRP	YOUTH	MSRP
BG	WTD107721	\$45 <sup>00</sup>	WTD207721	\$40 <sup>00</sup>
TW	WTD107710	\$45 <sup>00</sup>	WTD207710	\$40 <sup>00</sup>

**VETERAN™** MEN'S SIZES S-2X YOUTH SIZES S-XL

**PANT FEATURES:**

- 100% Polyester doubleknit (8 oz.)
- Athletic cut
- Two set in back pockets
- Double layered knees
- Double snap closure
- DeMarini Wordmark gripper elastic waistband
- Moisture wicking fabric



PIPING AVAILABLE \$8.60



ADULT: GRADUATED INSEAMS  
YOUTH: GRADUATED INSEAMS

OPTION	MEN	MSRP	YOUTH	MSRP
BG	WTD107821	\$35 <sup>00</sup>	WTD207821	\$30 <sup>00</sup>
TW	WTD107810	\$35 <sup>00</sup>	WTD207810	\$30 <sup>00</sup>

**VIP™** MEN'S SIZES S-2X YOUTH SIZES S-XL

**PANT FEATURES:**

- 100% Polyester doubleknit (8 oz.)
- Adjustable inseam: 28-34" on mens; 24-30" on youth
- Lightweight hook and loop system for custom length
- Boot cut fit with hemmed open bottom
- 2-set in back pockets
- Double layered knees
- DeMarini Wordmark gripper elastic waistband
- Moisture wicking fabric



PIPING AVAILABLE \$8.60



ADULT: 28-34" ADJUSTABLE HEM  
YOUTH: 24-30" ADJUSTABLE HEM

OPTION	MEN	MSRP	YOUTH	MSRP
BG	WTD1079BG	\$35 <sup>00</sup>	WTD2079BG	\$30 <sup>00</sup>
TW	WTD1079TW	\$35 <sup>00</sup>	WTD2079TW	\$30 <sup>00</sup>

**ADULT GRADUATED INSEAMS**

D	WTD1077	WTD1078
	SIZE	INSEAM
S	31"	16"
M	32"	18"
L	33"	18"
XL	33"	19"
2X	33"	19"

**YOUTH GRADUATED INSEAMS**

D	WTD2077	WTD2078
	SIZE	INSEAM
S	25"	10"
M	26"	12"
L	27"	14"
XL	28"	16"

# U500 FAUX BUTTON FRONT JERSEY WITH SET-IN SLEEVES, CONTRASTING INSERTS & WHITE PIPING DOWN FRONT



WOMEN'S SIZES  
**XS-2X**  
GIRLS SIZES  
**S-L**

## CHOOSE YOUR BRAND ON A STOCK JERSEY

**Shown With:**

- ◆ **WTL4982:** 2-color Jays vinyl lettering
- ◆ **WTL4957:** 2-color Air Force vinyl numerals on front
- ◆ **WTL4958:** 2-color Air Force vinyl numerals on front



**PRICE AS SHOWN**  
\$75<sup>00</sup>

**JERSEYS FEATURE:**

- ◆ 100% Polyester Double Bar Mesh
- ◆ Black/White side inserts pair with black and white pants
- ◆ Breathable side inserts
- ◆ Lightweight moisture wicking fabric

**WILSON**

WOMEN	MSRP	GIRLS	MSRP
WTA4600	\$33 <sup>00</sup>	WTA5600	\$31 <sup>00</sup>

**DEMARINI**

WOMEN	MSRP	GIRLS	MSRP
WTD4600	\$33 <sup>00</sup>	WTD5600	\$31 <sup>00</sup>

**LOUISVILLE SLUGGER**

WOMEN	MSRP	GIRLS	MSRP
WTL4600	\$33 <sup>00</sup>	WTL5600	\$31 <sup>00</sup>

**Shown With:**

- ◆ **WTL4982:** 2-color Brush Script vinyl lettering
- ◆ **WTL4957:** 2-color Army vinyl numerals on front
- ◆ **WTL4958:** 2-color Army vinyl numerals on front



**PRICE AS SHOWN**  
\$75<sup>00</sup>



**Shown With:**

- ◆ **WTL4982:** 2-color New England vinyl lettering
- ◆ **WTL4957:** 2-color Pro Block vinyl numerals on front
- ◆ **WTL4958:** 2-color Pro Block vinyl numerals on back



**PRICE AS SHOWN**  
\$75<sup>00</sup>



Side detail

**SIDE INSERT BREATHABILITY**

- AVAILABLE DECORATION:**
- ◆ TACKLE TWILL
  - ◆ SUBLIMATED TWILL
  - ◆ FILM TRANSFER

**FASTPITCH**

# T600

2-BUTTON PLACKET PULLOVER WITH FEMININE FIT

WOMEN'S SIZES  
**XS-2X**  
GIRLS SIZES  
**S-L**

**Shown With:**

- ♦ **WTL4954:** 2-color Vegas screen print lettering
- ♦ **WTL4925:** 2-color Vegas screen print numerals on front
- ♦ **WTL4925:** 2-color Vegas screen print numerals on back

**PRICE AS SHOWN**  
\$57<sup>00</sup>



AVAILABLE DECORATION:  
• SCREEN PRINTING  
• FILM TRANSFER

**JERSEY FEATURES:**

- ♦ 100% Polyester Pin Dot
- ♦ White piping outlines neck
- ♦ Breathable white side inserts
- ♦ Lightweight moisture wicking antimicrobial fabric

WOMEN	MSRP	GIRLS	MSRP
WTD4500	\$27 <sup>00</sup>	WTD5500	\$25 <sup>00</sup>

# T700 COMOTION™

V-NECK PULLOVER WITH FEMININE FIT

WOMEN'S SIZES  
**XS-2X**  
GIRLS SIZES  
**S-L**

**Shown With:**

- ♦ **WTL4954:** 2-color customer style lettering with logo
- ♦ **WTL4925:** 2-color Full Block numeral on back

**PRICE AS SHOWN**  
\$49<sup>00</sup>



AVAILABLE DECORATION:  
• SCREEN PRINTING  
• FILM TRANSFER

**JERSEY FEATURES:**

- ♦ 92% Polyester/8% Spandex Jersey Knit
- ♦ 4-way stretch fabric to maximize players range of motion
- ♦ Mesh inserts for strategic venting
- ♦ Lightweight moisture wicking antimicrobial fabric

WOMEN	MSRP	GIRLS	MSRP
WTD4400	\$29 <sup>00</sup>	WTD5400	\$27 <sup>00</sup>

# GAME DAY™

ATHLETIC FIT PULLOVER JERSEY

WOMEN'S SIZES  
**S-2X**

**Shown With:**

- ♦ **WTL4954:** 2-color Brush Script screen print lettering
- ♦ **WTL4925:** 2-color NCAA® screen print numerals on front
- ♦ **WTL4925:** 2-color NCAA® screen print numerals on back

**PRICE AS SHOWN**  
\$56<sup>99</sup>



AVAILABLE DECORATION:  
• SCREEN PRINTING  
• FILM TRANSFER

**JERSEY FEATURES:**

- ♦ 91% Polyester 9% Spandex
- ♦ Relaxed fit 4-way stretch performance top
- ♦ Contrast inserts
- ♦ Can be worn as a jersey, workout shirt or under a jersey
- ♦ Lightweight moisture wicking fabric

WOMEN	MSRP
WTD9901	\$26 <sup>99</sup>



# T800 SLEEVELESS TECH TEE

WOMEN'S SIZES  
**XS-2X**  
GIRLS SIZES  
**S-L**

**Shown With:**

- ◆ **WTL4954:** 2-color Fancy Block screen print lettering
- ◆ **WTL4925:** 2-color Fancy Block screen print numeral on front
- ◆ **WTL4925:** 2-color Fancy Block screen print numeral on back

**PRICE AS SHOWN**  
\$43<sup>00</sup>

**NEW**



**AVAILABLE DECORATION:**  
• SCREEN PRINTING  
• FILM TRANSFER

**JERSEY FEATURES:**

- ◆ 100% Polyester Interlock
- ◆ V-neck construction
- ◆ Contrast neck and arm openings
- ◆ Designed to be a lightweight jersey or training piece
- ◆ Lightweight moisture wicking fabric

WOMEN	MSRP	GIRLS	MSRP
WTD4700	\$13 <sup>00</sup>	WTD5700	\$12 <sup>00</sup>



# S303 PERFORMANCE V-NECK TECH TEE

ADULT SIZES  
**S-2X**  
YOUTH SIZES  
**S-L**

**Shown With:**

- ◆ **WTL4954:** 2-color custom screen print lettering
- ◆ **WTL4925:** 2-color Times Bold screen print numeral on front
- ◆ **WTL4925:** 2-color Times Bold screen print numeral on back

**PRICE AS SHOWN**  
\$45<sup>00</sup>

**NEW**



**AVAILABLE DECORATION:**  
• SCREEN PRINTING  
• FILM TRANSFER

**JERSEY FEATURES:**

- ◆ 100% Polyester Interlock
- ◆ V-neck construction
- ◆ Contrasting inner neck and sleeve ends
- ◆ Can be worn as a jersey, workout shirt, or under a jersey
- ◆ Lightweight moisture wicking antimicrobial fabric

ADULT	MSRP	YOUTH	MSRP
WTA1107	\$15 <sup>00</sup>	WTA2107	\$14 <sup>00</sup>



# S302 PERFORMANCE TECH TEE

ADULT SIZES  
**S-2X**  
YOUTH SIZES  
**S-L**

**Shown With:**

- ◆ **WTL4964:** 3-color Script lettering with tail #3
- ◆ **WTL4925:** 2-color NCAA™ screen print numerals on back

**PRICE AS SHOWN**  
\$31<sup>00</sup>



**AVAILABLE DECORATION:**  
• SCREEN PRINTING  
• FILM TRANSFER

**JERSEY FEATURES:**

- ◆ 100% Polyester Interlock
- ◆ Can be worn as a jersey, workout shirt, or under a jersey
- ◆ Lightweight moisture wicking antimicrobial fabric

ADULT	MSRP	YOUTH	MSRP
WTA1106	\$11 <sup>00</sup>	WTA2106	\$10 <sup>00</sup>



# UPRISING™

WOMEN'S SIZES  
**S-2X**

**PANT FEATURES:**

- 100% Polyester 8 oz. Double Knit
- Athletic fit with modern low-rise, and rear yoke (women's)
- Double layered knees
- 2-set in back pockets
- Logo elastic gripper waistband
- Moisture wicking



WOMEN: 20" INSEAM



COLOR/ WOMEN	STOCK NO.	MSRP
Black	WTD3077BL	\$40 <sup>00</sup>
Blue Grey	WTD3077BG	\$40 <sup>00</sup>
Navy	WTD3077NA	\$40 <sup>00</sup>
Team White	WTD3077TW	\$40 <sup>00</sup>

# FIERCE™

WOMEN'S SIZES  
**S-2X**

**PANT FEATURES:**

- 100% Polyester 8 oz. Double Knit
- Low-rise fit with elastic bottom
- Double layered knees
- 2-set in back pockets
- Wordmark gripper elastic waistband with drawcord
- Moisture wicking



WOMEN: 22" INSEAM



COLOR/ WOMEN	STOCK NO.	MSRP
Black	WTD3040BL	\$35 <sup>00</sup>
Blue Grey	WTD3040BG	\$35 <sup>00</sup>
Charcoal	WTD3040CH	\$35 <sup>00</sup>
Navy	WTD3040NA	\$35 <sup>00</sup>
Royal	WTD3040RO	\$35 <sup>00</sup>
Scarlet	WTD3040SC	\$35 <sup>00</sup>
Team White	WTD3040TW	\$35 <sup>00</sup>

# SLEEK™

WOMEN'S SIZES  
**S-2X**

**PANT FEATURES:**

- 100% Polyester 8 oz. Double Knit
- Low-rise fit with elastic bottom
- Double layered knees
- 2-set in back pockets
- Wordmark gripper elastic waistband with drawcord
- Moisture wicking



WOMEN: 22" INSEAM



COLOR/ WOMEN	STOCK NO.	MSRP
Black	WTD3076BL	\$30 <sup>00</sup>
Blue Grey	WTD3076BG	\$30 <sup>00</sup>
Charcoal	WTD3076CH	\$30 <sup>00</sup>
Navy	WTD3076NA	\$30 <sup>00</sup>
Royal	WTD3076RO	\$30 <sup>00</sup>
Scarlet	WTD3076SC	\$30 <sup>00</sup>
Team White	WTD3076TW	\$30 <sup>00</sup>

# GIRL'S BELTED PANT

GIRLS SIZES XS-L

**PANT FEATURES:**

- 100% Polyester 8 oz. Double Knit
- Low-rise fit with elastic bottom
- Double layered knees
- 2-set in back pockets
- Wordmark gripper elastic waistband with drawcord
- Moisture wicking



PIPING AVAILABLE  
\$8.60

GIRLS: GRADUATED INSEAMS



SIZE	INSEAM
XS	12"
S	14"
M	16"
L	18"

COLOR/GIRLS	STOCK NO.	MSRP
Black	WTD4040BL	\$30 <sup>00</sup>
Blue Grey	WTD4040BG	\$30 <sup>00</sup>
Charcoal	WTD4040CH	\$30 <sup>00</sup>
Navy	WTD4040NA	\$30 <sup>00</sup>
Royal	WTD4040RO	\$30 <sup>00</sup>
Scarlet	WTD4040SC	\$30 <sup>00</sup>
Team White	WTD4040TW	\$30 <sup>00</sup>

# GIRL'S SLEEK™

GIRLS SIZES XS-L

**PANT FEATURES:**

- 100% Polyester 8 oz. Double Knit
- Low-rise fit with elastic bottom
- Double layered knees
- 2-set in back pockets
- Wordmark gripper elastic waistband with drawcord
- Moisture wicking



PIPING AVAILABLE  
\$8.60

GIRLS: GRADUATED INSEAMS



SIZE	INSEAM
XS	12"
S	14"
M	16"
L	18"

COLOR/GIRLS	STOCK NO.	MSRP
Black	WTD4076BL	\$25 <sup>00</sup>
Blue Grey	WTD4076BG	\$25 <sup>00</sup>
Charcoal	WTD4076CH	\$25 <sup>00</sup>
Navy	WTD4076NA	\$25 <sup>00</sup>
Royal	WTD4076RO	\$25 <sup>00</sup>
Scarlet	WTD4076SC	\$25 <sup>00</sup>
Team White	WTD4076TW	\$25 <sup>00</sup>



**FASTPITCH**

**HEADBANDS**



**NEW**



- HEADBAND FEATURES:**
- ◆ 92% polyester/8% Spandex
  - ◆ Silicone gripper dots inside headband
  - ◆ Package contains 1 White/1 Black

	BRAND	COLOR	MSRP
WTD7710BW	DeMarini	1 Black/1 White	\$15 <sup>00</sup>
WTL7710BW	Louisville Slugger	1 Black/1 White	\$15 <sup>00</sup>

**BASEBALL/FASTPITCH**

**DEMARINI® GAME SOCKS**

UNISEX SIZES  
**S-XL**



SOCK	SHOE SIZE		
	MEN'S	WOMEN'S	KID'S
S	-	4-6	3Y-5Y
M	6-8	6-10	5Y-7Y
L	8-12	10-13	-
XL	12-15	-	-

- SOCK FEATURES:**
- ◆ 95% polyester/3% Spandex/2% Rubber
  - ◆ Knee high

UNISEX	MSRP
WTD4448	\$6 <sup>50</sup>

**ELASTIC BELT**

ADULT SIZE **1 1/2"** YOUTH SIZE **1"**

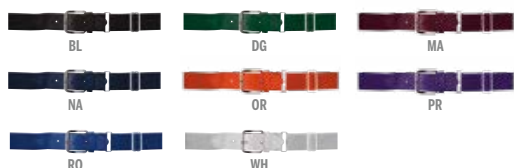

- BELT FEATURES:**
- ◆ Adult 1 1/2" wide is one-size-fits-most
  - ◆ Youth 1" wide fits waist sizes 18-32"
  - ◆ Minimum order is 6 per style, color

ADULT	MSRP	YOUTH	MSRP
WTA4442	\$6 <sup>00</sup>	WTA4444	\$5 <sup>50</sup>

**TEAM WEAR / P700**

WOMEN'S SIZES  
**S-2X**

- TEAM WEAR PANT FEATURES:**
- ◆ 100% Polyester 8.5 oz. Double Knit
  - ◆ Low-rise fit with elastic bottom
  - ◆ Double layered knees
  - ◆ 2-set in back pockets
  - ◆ Wordmark gripper elastic waistband
  - ◆ Moisture wicking
  - ◆ Sizes: S-2X

- P700 PANT FEATURES:**
- ◆ 100% Polyester Pro T3™ 9 oz. Warp Knit
  - ◆ Low-rise fit
  - ◆ 2" elastic waistband with drawstring
  - ◆ Moisture wicking and antimicrobial
  - ◆ Sizes: S-2X



**TEAM WEAR**  
22" INSEAM

**P700**  
24" INSEAM

PIPING AVAILABLE  
\$8.60

TEAM WEAR COLOR/WOMEN	STOCK NO.	MSRP
Black	WTC7605BL	\$30 <sup>00</sup>
Blue Grey	WTC7605BG	\$30 <sup>00</sup>
Team Grey	WTC7605GR	\$30 <sup>00</sup>
Team White	WTC7605WH	\$30 <sup>00</sup>



P700 COLOR/WOMEN	STOCK NO.	MSRP
Black	WTC7609BOBL00	\$25 <sup>00</sup>
Blue Grey	WTC7609BOGR00	\$25 <sup>00</sup>
Navy	WTC7609BONA00	\$25 <sup>00</sup>
Royal	WTC7609BORO00	\$25 <sup>00</sup>
Scarlet	WTC7609BOSC00	\$25 <sup>00</sup>
Team Grey	WTC7609BOTG00	\$25 <sup>00</sup>
Team White	WTC7609BOTW00	\$25 <sup>00</sup>
White	WTC7609BOWH00	\$25 <sup>00</sup>



# EVERY TEAM NEEDS ITS OWN IDENTITY

CREATE YOURS AT  
**WILSON.COM/CUSTOM/UNIFORMS**



## STOCK PANTS & JERSEYS WITH PIPING SHIPPED IN 72 HOURS

- Minimum order of 6 pieces, maximum order of 25 pieces per style and color
- Orders must be called into Sparta, TN customer service center at 800-468-8647 by 1:00 p.m. CT to qualify
- Program not available during factory closings
- Program turn based on product availability
- Program will be applied to one order per customer, per time
- MSRP \$8.60

### STOCK PANTS & JERSEYS PIPING & BRAID OPTIONS





CA	SC	MA	BR	TO	OR	DB	VG	LG	OG	TL	VB	RO	NA	PR	KG	DG	WH	PK	SG	BL
CARDINAL	SCARLET	MAROON	BURNT RED	TEXAS ORANGE	BURNT ORANGE	DARK BROWN	VEGAS GOLD	LIGHT GOLD	OLD GOLD	TEAL	VICTORY BLUE	ROYAL BLUE	NAVY BLUE	PURPLE	KELLY GREEN	DARK GREEN	WHITE	PINK	SILVER GREY	BLACK
<b>PIPING</b>																				
<b>BRAID</b>																				

### PIPING OPTIONS

DESCRIPTION	STOCK NO.	MSRP
 1 row piping on sleeves	WTA4307	\$5.60
 1 row piping on jersey armholes	WTA4309	\$6.60
 1 row piping around outer neck and down front	WTA4313	\$7.00
 1 row piping around inner neck	WTA4329*	\$6.00
 Piping on outseam of pant or shorts	WTA4367	\$8.60

Piping and braid available in all stock pants except WTA4374 and WTA4204  
Piping and braid available on stock jerseys WTD2300/WTD3300

### 1/2" BRAID OPTIONS\*

DESCRIPTION	STOCK NO.	MSRP
 1/2" braid on sleeves	WTA4326	\$8.00
 1/2" braid on sleeveless shirt armholes	WTA4315	\$8.60
 1 row 1/2" braid around neck and down front	WTA4314	\$11.40
 1 row 1/2" braid around neck	WTA4891	\$8.40
 1/2" braid on outseam	WTA4327	\$9.40

\*Braid Options not available for 72 hour program

### BRAID OPTIONS

#1: 3-color

#2: 3-color

#3: 2-color

#4: 1-color

#5: 2-color

### BASEBALL & FASTPITCH SIZE CHARTS

BASEBALL SIZE	JERSEYS (CHEST)		PANTS (WAIST)	
	ADULT	YOUTH	ADULT	YOUTH
XS	-	-	-	20
S	34-36	26-28	26-28	22-24
M	38-40	30-32	30-32	26-28
L	42-44	34-36	34-36	30-32
XL	46-48	38-40	38-40	34-36
2X	50-52	-	42-44	38
3X	54-56	-	46-48	-

FASTPITCH SIZE	JERSEYS (BUST)		PANTS (WAIST)	
	WOMEN	GIRLS	WOMEN	GIRLS
XS	29-31	-	22-24	-
S	32-34	26-28	25-27	23-24
M	35-37	29-31	28-30	25-27
L	38-40	32-34	31-33	28-30
XL	41-43	-	34-36	-
2X	44-46	-	37-39	-
3X	47-49	-	-	-

# BASEBALL TEAM APPAREL



**GAME DAY™ SHORT SLEEVE**

MEN'S SIZES **S-2X**

YOUTH SIZES **S-L**

MEN'S MSRP **\$26<sup>99</sup>**

YOUTH MSRP **\$22<sup>99</sup>**

**TEAM ISSUE**

- 91% Polyester / 9% Spandex
- Athletic fit four way stretch performance top
- Can be worn under jersey, as a workout shirt or as a jersey
- Contrast inserts



Black	Dark Green	Maroon	Navy	Purple	Royal	Scarlet
M: WTD9701BL Y: WTD9801BL	M: WTD9701DG Y: WTD9801DG	M: WTD9701MA Y: WTD9801MA	M: WTD9701NA Y: WTD9801NA	M: WTD9701PR Y: WTD9801PR	M: WTD9701RO Y: WTD9801RO	M: WTD9701SC Y: WTD9801SC

**GAME DAY™ LONG SLEEVE**

MEN'S SIZES **S-2X**

YOUTH SIZES **S-L**

MEN'S MSRP **\$28<sup>99</sup>**

YOUTH MSRP **\$24<sup>99</sup>**

**TEAM ISSUE**

- 91% Polyester / 9% Spandex
- Created to wear under a jersey
- Lightweight, loose fit shirt
- Contrast inserts

*COLORS AVAILABLE WHILE SUPPLIES LAST*



Black	Navy	Royal	Scarlet	Dark Green	Maroon	Purple
M: WTD9702BL Y: WTD9802BL	M: WTD9702NA Y: WTD9802NA	M: WTD9702RO Y: WTD9802RO	M: WTD9702SC Y: WTD9802SC	M: WTD9702DG Y: WTD9802DG	M: WTD9702MA Y: WTD9802MA	M: WTD9702PR Y: WTD9802PR

**COMOTION™ MID SLEEVE**

MEN'S SIZES **S-2X**

YOUTH SIZES **S-L**

MEN'S MSRP **\$34<sup>99</sup>**

YOUTH MSRP **\$29<sup>99</sup>**

**TEAM ISSUE**

- 87% Polyester / 13% Spandex
- Semi fitted body with fitted sleeves cut at the elbow
- Air-flowing mesh side inserts



Black	Navy	Royal	Scarlet
M: WTD1006BL Y: WTD2006BL	M: WTD1006NA Y: WTD2006NA	M: WTD1006RO Y: WTD2006RO	M: WTD1006SC Y: WTD2006SC

<b>HEATER™ FLEECE ½ ZIP</b>	MEN'S SIZES <b>S-3X</b>	YOUTH SIZES <b>S-L</b>	MEN'S MSRP <b>\$54<sup>99</sup></b>	YOUTH MSRP <b>\$49<sup>99</sup></b>	<b>TEAM ISSUE</b>
-----------------------------	-------------------------	------------------------	-------------------------------------	-------------------------------------	-------------------

- 100% Polyester Fleece
- Stand up collar
- 2 front pockets
- Contrast inserts



<b>Black</b>	<b>Charcoal</b>	<b>Navy</b>	<b>Royal</b>	<b>Scarlet</b>
M: WTD1010BL Y: WTD2010BL	M: WTD1010CH Y: WTD2010CH	M: WTD1010NA Y: WTD2010NA	M: WTD1010RO Y: WTD2010RO	M: WTD1010SC Y: WTD2010SC

<b>HEATER™ FLEECE</b>	MEN'S SIZES <b>S-3X</b>	YOUTH SIZES <b>S-L</b>	MEN'S MSRP <b>\$39<sup>99</sup></b>	YOUTH MSRP <b>\$34<sup>99</sup></b>	<b>TEAM ISSUE</b>
-----------------------	-------------------------	------------------------	-------------------------------------	-------------------------------------	-------------------

- 100% Polyester moisture wicking fabric
- Thermal insulated single sided Heater™ fleece allows for easy layering



<b>Black</b>	<b>Dark Green</b>	<b>Maroon</b>	<b>Navy</b>	<b>Purple</b>	<b>Royal</b>	<b>Scarlet</b>
M: WTD101170 Y: WTD201270	M: WTD101167 Y: WTD201267	M: WTD101197 Y: WTD201297	M: WTD101140 Y: WTD201240	M: WTD101130 Y: WTD201230	M: WTD101150 Y: WTD201250	M: WTD101190 Y: WTD201290

<b>FLEECE PANT</b>	MEN'S SIZES <b>S-3X</b>	YOUTH SIZES <b>S-L</b>	MEN'S MSRP <b>\$39<sup>99</sup></b>	YOUTH MSRP <b>\$34<sup>99</sup></b>	<b>TEAM ISSUE</b>
--------------------	-------------------------	------------------------	-------------------------------------	-------------------------------------	-------------------

- 100% Polyester
- 2 pockets
- DeMarini® logo waistband



<b>Black</b>	<b>Goatbelly Grey</b>
M: WTD107070 Y: WTD207070	M: WTD107020 Y: WTD207020

<b>GAME DAY™ BP</b>	MEN'S SIZES <b>S-2X</b>	YOUTH SIZES <b>S-L</b>	MEN'S MSRP <b>\$49<sup>99</sup></b>	YOUTH MSRP <b>\$44<sup>99</sup></b>	<b>TEAM ISSUE</b>
---------------------	-------------------------	------------------------	-------------------------------------	-------------------------------------	-------------------

- 94% Polyester / 6% Spandex
- Strategic mesh inserts for ventilation and freedom of movement
- Quarter zip neckline; bungee cord in the bottom hem to adjust fit

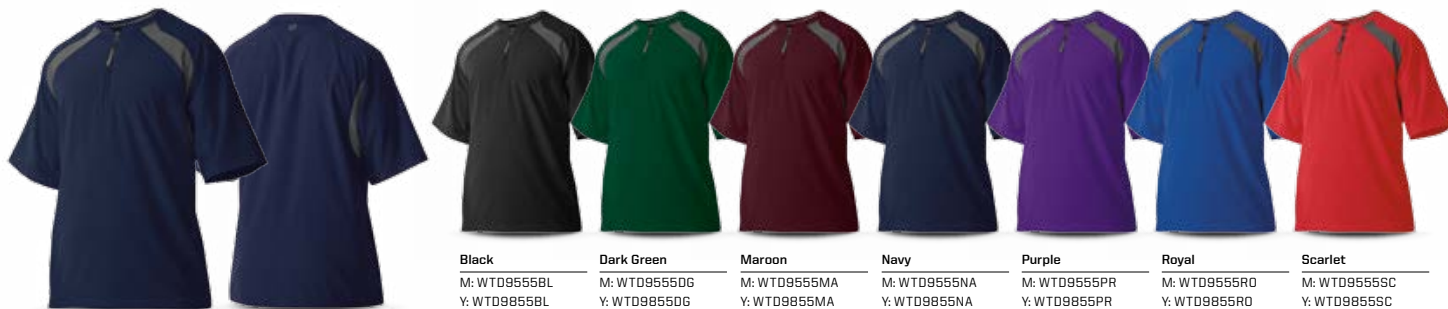

<b>DEMARINI® POLO</b>	MEN'S SIZES <b>S-3X</b>		MEN'S MSRP <b>\$34<sup>99</sup></b>	<b>TEAM ISSUE</b>
-----------------------	-------------------------	--	-------------------------------------	-------------------

- 100% Polyester
- 3-button placket; contrast side inserts
- Moisture wicking fabric



<b>UPRISING™ TRAINING SHORT</b>	MEN'S SIZES <b>S-3X</b>	YOUTH SIZES <b>S-L</b>	MEN'S MSRP <b>\$24<sup>99</sup></b>	YOUTH MSRP <b>\$19<sup>99</sup></b>	<b>TEAM ISSUE</b>
---------------------------------	-------------------------	------------------------	-------------------------------------	-------------------------------------	-------------------

- 100% Polyester
- Breathable mesh wicking fabric; designed for the daily workout
- Adult 11" inseam, Youth 8½" inseam



<b>WILSON® TRAINING SHORT</b>	MEN'S SIZES <b>S-3X</b>	YOUTH SIZES <b>S-L</b>	MEN'S MSRP <b>\$24<sup>99</sup></b>	YOUTH MSRP <b>\$19<sup>99</sup></b>	<b>TEAM ISSUE</b>
-------------------------------	-------------------------	------------------------	-------------------------------------	-------------------------------------	-------------------

- 100% Polyester lightweight fabric
- Designed for player workouts and practice
- Soft Wilson waistband with drawcord; 2 side pockets
- Adult 10¾" inseam, Youth 8" inseam







**EVOSHIELD BASEBALL**  
**TEAM APPAREL**



300 [GRAPHITE/RED]



200 [GRAPHITE/ROYAL]



400 [GRAPHITE/NAVY]



100 [GRAPHITE/BLACK]

**3/4 SHIRT**

		MSRP
WTV1024021	ADULT: S, M, L, XL, 2X	\$34.99
WTV1024021	YOUTH: YS, YM, YL	\$29.99

ATHLETIC CUT RAGLAN SLEEVES: for full range of motion  
DESIGNED WITH EVOSHIELD'S SIGNATURE SWAGTECH™ FABRIC  
IMPORTED

**FABRIC:** 82% Polyester /18% Spandex (BODY), 84% Polyester /16% Spandex (SLEEVES)



610 [GREY/RED]



420 [GREY/ROYAL]



410 [GREY/NAVY]



001 [GREY/BLACK]

**PULLOVER BATTING JACKET**

		MSRP
WTV1025710	ADULT: S, M, L, XL, 2XL	\$49.99

CINCH TAB  
EMBROIDERED LOGO  
QUARTER ZIP  
LOW-PROFILE COLLAR  
IMPORTED

**FABRIC:** 94% Polyester /6% Spandex



NA [NAVY]



CH [CHARCOAL]



BL [BLACK]

**NEW PRO TEAM SHORT**

		MSRP
WTV1066	ADULT: S, M, L, XL, 2X, 3X	\$29.99
WTV2066	YOUTH: S, M, L	\$24.99

DESIGNED FOR PLAYER WORKOUTS AND PRACTICE  
PLUSH EVOSHIELD® WAISTBAND WITH DRAWCORD  
2 SIDE POCKETS  
CONTRAST PIPING  
INSEAM: Adult - 10", Youth - 8"

**FABRIC:** 100% Polyester Midweight Fabric





GR [GREY]



NA [NAVY]



BL [BLACK]

**NEW PRO TEAM HOODIE**

		MSRP
WTV1089	ADULT: S, M, L, XL, 2L, 3X	\$49.99
WTV2089	YOUTH: S, M, L	\$44.99

3-PIECE HOOD  
KANGAROO FRONT POCKET  
HIDDEN ZIPPERED MEDIA POCKET  
MOISTURE-WICKING FABRIC

**FABRIC:** 100% Polyester



CN [CHARCOAL/NAVY]



CS [CHARCOAL/SCARLET]



CR [CHARCOAL/ROYAL]



CB [CHARCOAL/BLACK]

**NEW PRO TEAM ¼ ZIP**

		MSRP
WTV1013	ADULT: S, M, L, XL, 2X, 3X	\$39.99
WTV2013	YOUTH: S, M, L	\$34.99

LIGHTWEIGHT HEATHERED FABRIC  
RELAXED FIT  
CONTRASTING SHOULDERS, BACK AND COLLAR

**FABRIC:** 100% Polyester



BL [BLACK]



RO [ROYAL]



SC [SCARLET]



NA [NAVY]

**NEW PRO TEAM WINTERBALL**

		MSRP
WTV1030	ADULT: S, M, L, XL, 2X, 3X	\$39.99
WTV2030	YOUTH: S, M, L	\$34.99

WINTER WEIGHT WITH BRUSHED BACK  
LOOSE COMPRESSION FIT  
HIGH CREW NECK

**FABRIC:** 90% Polyester / 10% Spandex







# FASTPITCH TEAM APPAREL

FP TEAM APPAREL

**GAME DAY™ SHORT SLEEVE**

WOMEN'S SIZES **S-2X**

WOMEN'S MSRP **\$26<sup>99</sup>**

**TEAM ISSUE**

- 91% Polyester / 9% Spandex
- Athletic fit four way stretch performance top
- Can be worn under jersey, as a workout shirt or as a jersey
- Contrast inserts



**GAME DAY™ LONG SLEEVE**

WOMEN'S SIZES **S-2X**

WOMEN'S MSRP **\$28<sup>99</sup>**

**TEAM ISSUE**

- 91% Polyester / 9% Spandex
- Created to wear under a jersey
- Lightweight, loose fit shirt
- Contrast inserts

*COLORS AVAILABLE WHILE SUPPLIES LAST*



**FLEECE ¼ ZIP**

WOMEN'S SIZES **S-XL**

WOMEN'S MSRP **\$44<sup>99</sup>**

**TEAM ISSUE**

- 86% Polyester / 14% Spandex
- Lightweight space dyed fleece, brushed on the inside
- Raglan sleeves with thumbholes
- ¼ zip front, 1 zippered side pocket

*NEW COLORS*



### V-NECK HOODIE

WOMEN'S SIZES **S-XL**

WOMEN'S MSRP **\$39<sup>99</sup>**

**TEAM ISSUE**

- 100% Polyester lightweight heathered fabric
- Relaxed fit cover-up
- Curved hem, longer in the back
- Deep v-neck
- Contrast placket, hood lining, and sleeve binding



**NEW**



**Black**

W: WTD3080BL

**Charcoal**

W: WTD3080CH

**Navy**

W: WTD3080NA

### TRAINING CAPRI

WOMEN'S SIZES **S-XL**

WOMEN'S MSRP **\$39<sup>99</sup>**

**TEAM ISSUE**

- 92% Polyester / 8% Spandex 4-way stretch moisture wicking fabric
- Back leg mesh inserts for breathability
- Waistband slit pocket for valuables
- Perfect length for practice or working out



**Black**

W: WTD3041BL

**Charcoal**

W: WTD3041CH

### TRAINING SHORT

WOMEN'S SIZES **S-2X**

WOMEN'S MSRP **\$29<sup>99</sup>**

**TEAM ISSUE**

- 100% Polyester lightweight moisture-wicking material
- Woven embossed fabric
- Flattering relaxed fit allows for ease of movement
- Encased waistband with drawcord
- Graded inseams



**NEW**



**Black**

W: WTD3020BL

**Charcoal**

W: WTD3020CH



<b>FLEECE PANT</b>	WOMEN'S SIZES <b>S-XL</b>	WOMEN'S MSRP <b>\$49<sup>99</sup></b>	<b>TEAM ISSUE</b>
--------------------	---------------------------	---------------------------------------	-------------------

- 100% Polyester moisture wicking fabric
- 2 pockets
- Rollover waistband with DeMarini® logo

*COLOR AVAILABLE WHILE SUPPLIES LAST*



**Black**  
W: WTD307070



**Goatbelly Grey**  
W: WTD307020



**Navy**  
W: WTD307071

<b>HEATER™ FLEECE</b>	WOMEN'S SIZES <b>S-XL</b>	WOMEN'S MSRP <b>\$39<sup>99</sup></b>	<b>TEAM ISSUE</b>
-----------------------	---------------------------	---------------------------------------	-------------------

- 100% Polyester. Single sided Heater™ fleece allows for easy layering
- Thermal insulated
- Moisture wicking fabric

*WHILE SUPPLIES LAST*



**Black**  
W: WTD301170



**Dark Green**  
W: WTD301167



**Maroon**  
W: WTD301197



**Navy**  
W: WTD301140



**Purple**  
W: WTD301130



**Royal**  
W: WTD301150



**Scarlet**  
W: WTD301190

<b>YARD-WORK™ TRAINING SHORT</b>	WOMEN'S SIZES <b>S-XL</b>	WOMEN'S MSRP <b>\$24<sup>99</sup></b>	<b>TEAM ISSUE</b>
----------------------------------	---------------------------	---------------------------------------	-------------------

- 100% Polyester
- Lightweight stretch woven fabric
- Back pocket with zip closure

*WHILE SUPPLIES LAST*



**Black/Goatbelly Grey**  
W: WTD301601



**Hot Pink/Goatbelly Grey**  
W: WTD301602



**Navy/Goatbelly Grey**  
W: WTD301604



**Scarlet/Goatbelly Grey**  
W: WTD301603





# HATS & BRAND TEES



HATS & TEES





# EVOSHIELD® BRAND HATS



RED/WHITE MESH

ROYAL/WHITE MESH

## USA SNAPBACK TRUCKER

		MSRP
WTV10343206200SFM	RED/WHITE: ONE SIZE	\$29.99
WTV10343204300SFM	ROYAL/WHITE: ONE SIZE	\$29.99

EMBROIDERED RAISED EVOSHIELD® LOGO WITH AMERICAN FLAG DESIGN  
 BREATHABLE MESH BACK TO KEEP YOU COOL  
 SNAPBACK FIT ALLOWS FOR FULL ADJUSTABILITY  
 IMPORTED

**FABRIC:** 53% Polyester / 47% Cotton



HEATHER GREY/WHITE MESH

## THROWBACK PATCH SNAPBACK

		MSRP
WTV10373300600SFM	ONE SIZE	\$29.99

EMBROIDERED CLASSIC RAISED EVOSHIELD® LOGO  
 BREATHABLE MESH BACK TO KEEP YOU COOL  
 SNAPBACK FIT ALLOWS FOR FULL ADJUSTABILITY  
 IMPORTED

**FABRIC:** 47% Nylon / 42% Acrylic / 11% Wool



BLACK/WHITE MESH

## NEW ES SNAPBACK

		MSRP
WTV8706BLOSFM	ONE SIZE	\$29.99

SEWN ON WOVEN PATCH  
 FEATURES SUBLIMATED BILL  
 SNAPBACK FIT ALLOWS FOR FULL ADJUSTABILITY  
 BREATHABLE MESH BACK TO KEEP YOU COOL  
 EVO FORM BILL ALLOWS YOU TO CURVE THE BILL TO YOUR PREFERENCE  
 IMPORTED

**FABRIC:** 47% Nylon / 42% Acrylic / 11% Wool

HATS & TEES





BLACK/WHITE MESH

**CLASSIC CREST FLATBILL SNAPBACK**

		MSRP
WTV10373500010SFM	ONE SIZE	\$29. <sup>99</sup>

SEWN-ON "WE ARE ATHLETES" / CROSS BAT EVOSHIELD® PATCH  
 BREATHABLE MESH BACK TO KEEP YOU COOL  
 SNAPBACK FIT ALLOWS FOR FULL ADJUSTABILITY  
 IMPORTED

**FABRIC:** 47% Nylon / 42% Acrylic / 11% Wool



WHITE/NAVY MESH

**FLAG PATCH SNAPBACK TRUCKER**

		MSRP
WTV10373004100SFM	ONE SIZE	\$29. <sup>99</sup>

EMBROIDERED RAISED EVOSHIELD® STARS AND SEAMS FLAG  
 BREATHABLE MESH BACK TO KEEP YOU COOL  
 SNAPBACK FIT ALLOWS FOR FULL ADJUSTABILITY  
 IMPORTED

**FABRIC:** 47% Nylon / 42% Acrylic / 11% Wool



CHARCOAL

**NEW SCRIPT SNAPBACK**

		MSRP
WTV8702CH0SFM	ONE SIZE	\$29. <sup>99</sup>

EMBROIDERED 3D EVOSHIELD® WORDMARK  
 SNAPBACK FIT ALLOWS FOR FULL ADJUSTABILITY  
 EVO FORM BILL ALLOWS YOU TO CURVE THE BILL TO YOUR PREFERENCE  
 IMPORTED

**FABRIC:** 80% Acrylic / 20% Wool



# EVOSHIELD® BRAND HATS



NAVY/WHITE MESH

## NEW ES WRAP SNAPBACK

		MSRP
WTV8710NW0SFM	ONE SIZE	\$29. <sup>99</sup>

EMBROIDERED ES LOGO  
 SNAPBACK FIT ALLOWS FOR FULL ADJUSTABILITY  
 EVO FORM BILL ALLOWS YOU TO CURVE THE BILL TO YOUR PREFERENCE  
 IMPORTED

**FABRIC:** 47% Nylon / 42% Acrylic / 11% Wool



BLACK

## TOURNEY EVOLITE™ FLEXFIT

		MSRP
WTV103646001LGXL	SIZE: L/XL (7 <sup>3</sup> / <sub>16</sub> -7 <sup>7</sup> / <sub>16</sub> )	\$29. <sup>99</sup>
WTV103646001SMMD	SIZE: S/M (7-7 <sup>3</sup> / <sub>16</sub> )	\$29. <sup>99</sup>

EMBROIDERED EVOSHIELD® LOGO  
 LIGHTWEIGHT PERFORMANCE BLEND FABRIC  
 EVOFORM VISOR ALLOWS YOU TO CURVE THE VISOR TO YOUR PREFERENCE  
 LASER CUT PERFORATIONS KEEP YOU COOL AND DRY  
 IMPORTED

**FABRIC:** 98% Polyester / 2% P.U. Spandex



BLACK/NEON MESH

## NEW NEON ONSLAUGHT FLEXFIT

		MSRP
WTV8708BNLGXL	SIZE: L/XL (7 <sup>3</sup> / <sub>16</sub> -7 <sup>7</sup> / <sub>16</sub> )	\$29. <sup>99</sup>
WTV8708BNSMMD	SIZE: S/M (7-7 <sup>3</sup> / <sub>16</sub> )	\$29. <sup>99</sup>

SONIC WELD EVOSHIELD® LOGO  
 FEATURES SUBLIMATED BILL PATTERN  
 FLEXFIT BAND FOR ULTIMATE COMFORT FIT  
 BREATHABLE MESH BACK TO KEEP YOU COOL  
 PRE-FORMED BILL  
 IMPORTED

**FABRIC:** 56% Polyester / 42% Cotton / 2% P.U. Spandex



BLACK/WHITE MESH

**NEW CIRCLE FLEXFIT**

		MSRP
WTV8700BWLGL	SIZE: L/XL (7 <sup>1</sup> / <sub>6</sub> -7 <sup>5</sup> / <sub>8</sub> )	\$29. <sup>99</sup>
WTV8700BWSMMD	SIZE: S/M (7-7 <sup>1</sup> / <sub>4</sub> )	\$29. <sup>99</sup>

FEATURES AN EMBROIDERED SEWN-ON PATCH LOGO  
BREATHABLE MESH BACK TO KEEP YOU COOL  
PRE-FORMED BILL  
IMPORTED

**FABRIC:** 56% Polyester / 42% Cotton / 2% P.U. Spandex



BLACK/GREY MESH

**SPEED STRIPE™ FLEXFIT TRUCKER**

		MSRP
WTV1036380003LGL	SIZE: L/XL (7 <sup>1</sup> / <sub>6</sub> -7 <sup>5</sup> / <sub>8</sub> )	\$29. <sup>99</sup>
WTV1036380003SMMD	SIZE: S/M (7-7 <sup>1</sup> / <sub>4</sub> )	\$29. <sup>99</sup>

EMBROIDERED EVOSHIELD® LOGO  
BREATHABLE MESH BACK TO KEEP YOU COOL  
FLEXFIT BAND FOR ULTIMATE COMFORT FIT  
PRE-FORMED BILL  
IMPORTED

**FABRIC:** 56% Polyester / 42% Cotton / 2% P.U. Spandex



BLACK

**NEW GOLD THREAD FLEXFIT**

		MSRP
WTV8712BGLGL	SIZE: L/XL (7 <sup>1</sup> / <sub>6</sub> -7 <sup>5</sup> / <sub>8</sub> )	\$29. <sup>99</sup>
WTV8712BGSMMD	SIZE: S/M (7-7 <sup>1</sup> / <sub>4</sub> )	\$29. <sup>99</sup>

FEATURES AN EMBROIDERED EVOSHIELD® LOGO  
FLEXFIT BAND FOR ULTIMATE COMFORT FIT  
EVO FORM BILL ALLOWS YOU TO CURVE THE BILL TO YOUR PREFERENCE  
IMPORTED

**FABRIC:** 98% Polyester / 2% P.U. Spandex





# EVOSHIELD® BRAND HATS



NAVY/WHITE MESH

## USA FLEXFIT TRUCKER

		MSRP
WTV1035320410LGXL	SIZE: L/XL (7 <sup>3</sup> / <sub>16</sub> -7 <sup>7</sup> / <sub>16</sub> )	\$29. <sup>99</sup>
WTV1035320410SMMD	SIZE: S/M (7-7 <sup>3</sup> / <sub>16</sub> )	\$29. <sup>99</sup>

EVOSHIELD LOGO WITH AMERICAN FLAG DESIGN  
BREATHABLE MESH BACK TO KEEP YOU COOL  
FLEXFIT BAND FOR ULTIMATE COMFORT FIT  
PRE-FORMED BILL  
IMPORTED

**FABRIC:** 56% Polyester / 42% Cotton / 2% P.U. Spandex



REALTREE XTRA/OLIVE GREEN MESH

## OUTDOOR FLEXFIT

		MSRP
WTV1037360961LGXL	SIZE: L/XL (7 <sup>3</sup> / <sub>16</sub> -7 <sup>7</sup> / <sub>16</sub> )	\$29. <sup>99</sup>
WTV1037360961SMMD	SIZE: S/M (7-7 <sup>3</sup> / <sub>16</sub> )	\$29. <sup>99</sup>

EMBROIDERED EVOSHIELD LOGO  
BREATHABLE MESH BACK TO KEEP YOU COOL  
FLEXFIT BAND FOR ULTIMATE COMFORT FIT  
PRE-FORMED BILL  
IMPORTED

**FABRIC:** 98% Polyester / 2% P.U. Spandex



WHITE/GREY

## HOME TEAM FLEXFIT

		MSRP
WTV1037310030LGXL	SIZE: L/XL (7 <sup>3</sup> / <sub>16</sub> -7 <sup>7</sup> / <sub>16</sub> )	\$29. <sup>99</sup>
WTV1037310030SMMD	SIZE: S/M (7-7 <sup>3</sup> / <sub>16</sub> )	\$29. <sup>99</sup>

SONIC WELD EVOSHIELD LOGO  
SUBLIMATED GRADIENT PATTERN  
LIGHTWEIGHT PERFORMANCE BLEND FABRIC  
EVOFORM VISOR ALLOWS YOU TO CURVE THE VISOR TO YOUR PREFERENCE  
LASER CUT PERFORATIONS KEEP YOU COOL AND DRY  
IMPORTED

**FABRIC:** 98% Polyester / 2% P.U. Spandex



CHARCOAL/WHITE MESH

BLACK/WHITE MESH

**GRANDSTAND™ FLEXFIT**

		MSRP
WTV1035344030LGXL	[CHARCOAL] SIZE: L/XL (7 <sup>3</sup> / <sub>16</sub> -7 <sup>5</sup> / <sub>16</sub> )	\$29. <sup>99</sup>
WTV1035344030SMMD	[CHARCOAL] SIZE: S/M (7-7 <sup>1</sup> / <sub>4</sub> )	\$29. <sup>99</sup>
WTV1035344010LGXL	[BLACK] SIZE: L/XL (7 <sup>3</sup> / <sub>16</sub> -7 <sup>5</sup> / <sub>16</sub> )	\$29. <sup>99</sup>
WTV1035344010SMMD	[BLACK] SIZE: S/M (7-7 <sup>1</sup> / <sub>4</sub> )	\$29. <sup>99</sup>

APPLIQUÉ AND EMBROIDERED FRONT DECORATION  
 BREATHABLE MESH BACK TO KEEP YOU COOL  
 FLEXFIT BAND FOR ULTIMATE COMFORT FIT  
 PRE-FORMED BILL  
 IMPORTED

**FABRIC:** 56% Polyester / 42% Cotton / 2% P.U. Spandex



EVO CAMO

WHITE

**BUCKET HAT**

		MSRP
WTV10360000560SFM	[CAMO] ONE SIZE	\$24. <sup>99</sup>
WTV10360001000SFM	[WHITE] ONE SIZE	\$24. <sup>99</sup>

WIDE BRIM HELPS SHIELD THE SUN  
 LASER CUTS AND MESH VENTS IN CROWN FOR BREATHABILITY  
 ADJUSTABLE STRAP AND DRAWSTRING AT BACK FOR COMFORTABLE FIT  
 EMBROIDERED EVOSHIELD LOGO

**FABRIC:** 100% Polyester

# W | WILSON® BRAND HATS



RED/WHITE MESH

## NEW W® HOME PLATE FLEXFIT RED

		MSRP
WTA7102RWLGXL	SIZE: L/XL (7 <sup>1</sup> / <sub>6</sub> -7 <sup>7</sup> / <sub>8</sub> )	\$29. <sup>99</sup>
WTA7102RWSMMD	SIZE: S/M (7-7 <sup>1</sup> / <sub>4</sub> )	\$29. <sup>99</sup>

EMBROIDERED WILSON HOME PLATE LOGO  
 FEATURES SUBLIMATED PATTERN  
 FLEXFIT BAND FOR ULTIMATE COMFORT FIT  
 FLAT BILL ALLOWS YOU TO CURVE YOUR BILL TO YOUR PREFERENCE  
 IMPORTED

**FABRIC:** 98% Polyester / 2% PU Spandex

# D | DEMARINI® BRAND HATS



WHITE/FLIPPER BLUE MESH

## NEW D® PENNANT FLEXFIT

		MSRP
WTD1072WBLGXL	SIZE: L/XL (7 <sup>1</sup> / <sub>6</sub> -7 <sup>7</sup> / <sub>8</sub> )	\$29. <sup>99</sup>
WTD1072WBSMMD	SIZE: S/M (7-7 <sup>1</sup> / <sub>4</sub> )	\$29. <sup>99</sup>

FEATURES AN EMBROIDERED DEMARINI LOGO  
 FLEXFIT BAND FOR ULTIMATE COMFORT FIT  
 FLAT BILL ALLOWS YOU TO CURVE YOUR BILL TO YOUR PREFERENCE  
 IMPORTED

**FABRIC:** 98% Polyester / 2% PU Spandex

# LS | LOUISVILLE SLUGGER® BRAND HATS



GREY/WHITE MESH

## NEW LS FLEXFIT

		MSRP
WTL8702GWLGXL	SIZE: L/XL (7 <sup>1</sup> / <sub>6</sub> -7 <sup>7</sup> / <sub>8</sub> )	\$29. <sup>99</sup>
WTL8702GWSMMD	SIZE: S/M (7-7 <sup>1</sup> / <sub>4</sub> )	\$29. <sup>99</sup>

FEATURES EMBROIDERED 3D LS LOGO  
 FLEXFIT BAND FOR ULTIMATE COMFORT FIT  
 PRE-FORMED BILL  
 BREATHABLE MESH TO KEEP YOU COOL  
 IMPORTED

**FABRIC:** 56% Polyester / 42% Cotton / 2% PU Spandex





GREY HEATHER/NAVY

**NEW A2000 HEATHER SNAPBACK**

WTA7104GYOSFM	ONE SIZE	MSRP \$29. <sup>99</sup>
---------------	----------	-----------------------------

FEATURES A 3D EMBROIDERED LOGO  
 SUBLIMATED BILL  
 SNAPBACK FIT ALLOWS FOR FULL ADJUSTABILITY  
 FLAT BILL ALLOWS YOU TO CURVE YOUR BILL TO YOUR PREFERENCE  
 IMPORTED

**FABRIC:** 80% Acrylic / 20% Wool



NAVY MESH

**NEW 1979 SNAPBACK**

WTD1074NAOSFM	ONE SIZE	MSRP \$29. <sup>99</sup>
---------------	----------	-----------------------------

FEATURES AN EMBROIDERED DEMARINI LOGO  
 SNAPBACK FIT ALLOWS FOR FULL ADJUSTABILITY  
 BREATHABLE MESH BACK TO KEEP YOU COOL  
 FLAT BILL ALLOWS YOU TO CURVE YOUR BILL TO YOUR PREFERENCE  
 IMPORTED

**FABRIC:** 47% Nylon / 42% Acrylic / 11% Wool



NAVY

**NEW LS MERICA FLEXFIT**

WTL8704NALGXL	SIZE: L/XL (7 1/2-7 7/8)	MSRP \$29. <sup>99</sup>
WTL8704NASMMD	SIZE: S/M (7-7 3/4)	MSRP \$29. <sup>99</sup>

FEATURES AN EMBROIDERED LOUISVILLE SLUGGER AMERICA LOGO  
 FLEXFIT BAND FOR ULTIMATE COMFORT  
 FLAT BILL ALLOWS YOU TO CURVE YOUR BILL TO YOUR PREFERENCE  
 IMPORTED

**FABRIC:** 98% Polyester / 2% PU Spandex

**EVOSHIELD** | **EVOSHIELD**<sup>®</sup> BRAND TEES



**CUTOUT**

		MSRP
WTV8612BL	ADULT: S, M, L, XL, 2X	\$24 <sup>99</sup>
LOOSE FIT, PERFORMANCE GRAPHIC T-SHIRT SCREEN PRINT DECORATION MOISTURE WICKING		
<b>FABRIC:</b> 96% Polyester / 4% Spandex		

**SALUTE™**

		MSRP
WTV8611WH	ADULT: S, M, L, XL, 2X	\$24 <sup>99</sup>
LOOSE FIT, PERFORMANCE GRAPHIC T-SHIRT SCREEN PRINT DECORATION		
<b>FABRIC:</b> 58% Cotton / 42% Polyester		

**W** | **WILSON**<sup>®</sup> BRAND TEES



**W® BASEBALL**

		MSRP
WTA8610BL	ADULT: S, M, L, XL, 2X	\$24 <sup>99</sup>
LOOSE FIT, PERFORMANCE GRAPHIC T-SHIRT SCREEN PRINT DECORATION		
<b>FABRIC:</b> 58% Cotton / 42% Polyester		

**HOME PLATE**

		MSRP
WTA8611CH	ADULT: S, M, L, XL, 2X	\$24 <sup>99</sup>
LOOSE FIT, PERFORMANCE GRAPHIC T-SHIRT SCREEN PRINT DECORATION		
<b>FABRIC:</b> 58% Cotton / 42% Polyester		

**DEMARINI**<sup>®</sup> BRAND TEES



**ROUND TRIPPER™**

WTD8611NA	ADULT: S, M, L, XL, 2X	MSRP \$24 <sup>99</sup>
-----------	------------------------	----------------------------

LOOSE FIT, PERFORMANCE GRAPHIC T-SHIRT  
SCREEN PRINT DECORATION

**FABRIC:** 58% Cotton/42% Polyester

**LONGER SINCE FOREVER**

WTD8610CH	ADULT: S, M, L, XL, 2X	MSRP \$24 <sup>99</sup>
-----------	------------------------	----------------------------

LOOSE FIT, PERFORMANCE GRAPHIC T-SHIRT  
HEAT SEAL DECORATION

**FABRIC:** 58% Cotton/42% Polyester

**LOUISVILLE SLUGGER**<sup>®</sup> BRAND TEES



**LS NEON**

WTL8610CH	ADULT: S, M, L, XL, 2X	MSRP \$24 <sup>99</sup>
-----------	------------------------	----------------------------

LOOSE FIT, PERFORMANCE GRAPHIC T-SHIRT  
SCREEN PRINT DECORATION

**FABRIC:** 58% Cotton/42% Polyester

**PRIME: THE HARD TRUTH**

WTL8611BL	ADULT: S, M, L, XL, 2X	MSRP \$24 <sup>99</sup>
-----------	------------------------	----------------------------

LOOSE FIT, PERFORMANCE GRAPHIC T-SHIRT  
SCREEN PRINT DECORATION  
MOISTURE WICKING

**FABRIC:** 96% Polyester/4% Spandex





W



D

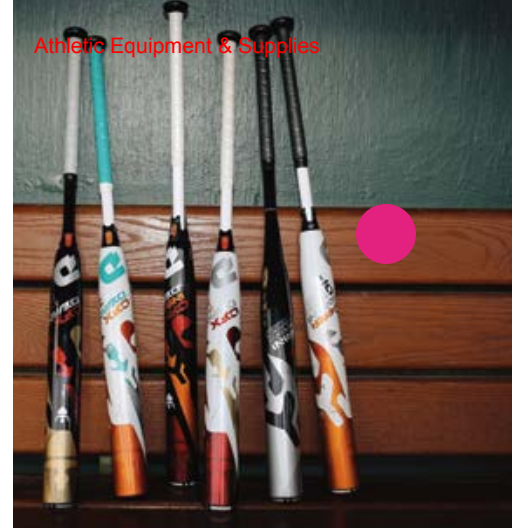

LS



EVOSHIELD  
GAME-CHANGING PROTECTIVE GEAR



ATEC



# COMBINED PRODUCT ASSORTMENT



# WILSON TEAM SPORTS SALES OFFICES

## MIDWEST

### REGIONAL SALES MANAGER

Dave Marrinan  
20845 Idaho Avenue  
Lakeville, MN 55044  
Phone: 612-991-7249  
Fax: 952-469-1182  
dave.marrinan@wilson.com

### COLORADO, WYOMING

Jamie Andra  
Phone: 847-682-9460  
Office: 303-663-4051  
Fax: 303-663-4052  
jamie.andra@wilson.com

### INDIANA, NORTHERN KENTUCKY

Andrew Coss  
Phone: 312-513-8486  
Fax: 317-769-0199  
andrew.coss@wilson.com

### MINNESOTA, NORTH DAKOTA

Greg Kamleiter  
Phone: 612-750-4706  
Fax: 952-469-1182  
greg.kamleiter@wilson.com

### WISCONSIN, MICHIGAN (U.P.), NORTHERN ILLINOIS

Rick Miller  
Phone: 630-240-2675  
rick.miller@wilson.com

### CHICAGOLAND, WESTERN ILLINOIS, EASTERN IOWA

Kelly Smith  
Phone: 773-495-4494  
Fax: 630-462-1481  
kelly.smith@wilson.com

### MISSOURI, SOUTHERN ILLINOIS, SOUTHWEST INDIANA

John Wilson  
Phone: 317-417-7704  
Office: 773-714-6400  
Fax: 636-294-4466  
john.wilson@wilson.com

### SOUTH DAKOTA, NEBRASKA, KANSAS, WESTERN IOWA

Bill Youngblood  
Phone: 913-484-6360  
Fax: 913-362-8867  
bill.youngblood@wilson.com

## NORTHEAST

### REGIONAL SALES MANAGER

Mike O'Brien  
986 Greensview Dr  
Wooster, OH 44691  
Phone: 330-465-6254  
mike.obrien@wilson.com

### WESTERN PENNSYLVANIA, WESTERN NEW YORK

Tom Berl  
Phone: 724-824-1312  
Fax: 724-824-1314  
tom.berl@wilson.com

### EASTERN PENNSYLVANIA, GREATER PHILADELPHIA

Mike O'Brien  
Phone: 330-465-6254  
mike.obrien@wilson.com

### SOUTHERN OHIO, EASTERN KENTUCKY, WEST VIRGINIA

Donald Leet  
Phone: 614-580-9555  
don.leet@wilson.com

### NEW JERSEY

Bill McDermott  
Phone: 973-769-3400  
Fax: 973-807-1649  
bill.mcdermott@wilson.com

### MASSACHUSETTS, RHODE ISLAND, MAINE

Brian Meehan  
Phone: 617-847-8937  
Office: 617-510-6575  
brian.meehan@wilson.com

### MARYLAND, DELAWARE

Colin Noonan  
Phone: 443-280-1623  
Office: 410-531-6914  
Fax: 443-535-8806  
colin.noonan@wilson.com

### NORTHERN OHIO

Matt Sherrieb  
Phone: 330-464-5366  
Fax: 330-601-0244  
matt.sherrieb@wilson.com

## MICHIGAN

Ryan Sulek  
Phone: 586-596-8014  
ryan.sulek@wilson.com

## CONNECTICUT, LONG ISLAND

Dave Williams  
Phone: 860-657-1036  
Fax: 860-633-5970  
dave.williams@wilson.com

## EASTERN NEW YORK, NEW YORK CITY, VERMONT, NEW HAMPSHIRE

Robert Rowen  
Phone: 845-633-1278  
robert.rowen@wilson.com

## SOUTH

### REGIONAL SALES MANAGER

Jay Schindler  
20415 Chapel Glen Court  
Katy, TX 77450  
Phone: 713-299-7597  
Fax: 281-578-7152  
jay.schindler@wilson.com

### ARKANSAS, NORTH MISSISSIPPI, NORTHWEST LOUISIANA

Eric Allen  
Phone: 812-989-2794  
Fax: 800-758-9805  
eric.allen@wilson.com

### TENNESSEE, SOUTHERN KENTUCKY, SOUTHEAST MISSOURI

Jim Conroy  
Phone: 773-255-3712  
Fax: 615-246-2722  
jim.conroy@wilson.com

### DALLAS, NORTHEAST TEXAS, OKLAHOMA

Mark Diaz  
Phone: 469-450-3112  
Office: 972-429-8780  
Fax: 972-429-8784  
mark.diaz@wilson.com

### SOUTH TEXAS

Steve Fairbanks  
Phone: 502-417-5560  
Fax: 281-809-6918  
steve.fairbanks@wilson.com

### SOUTHERN LOUISIANA, SOUTHERN MISSISSIPPI

Brian Mahoney  
Phone: 502-938-9963  
Fax: 318-404-1511  
brian.mahoney@wilson.com

### FORT WORTH, NORTHWEST, CENTRAL & WEST TEXAS

Heath Stanford  
Phone: 512-627-1989  
Fax: 972-767-3215  
heath.stanford@wilson.com

## SOUTHEAST

### REGIONAL SALES MANAGER

Mike Matthews  
Lakewood Ranch, FL34211  
Phone: 502-295-5813  
Fax: 251-650-1772  
mike.matthews@wilson.com

### NORTH CAROLINA, EASTERN TENNESSEE

Brent Blake  
Phone: 704-321-3253  
Fax: 980-209-0777  
brent.blake@wilson.com

### CENTRAL & SOUTH FLORIDA

Brian Bryant  
Phone: 941-730-7697  
Fax: 941-729-9559  
brian.bryant@wilson.com

### NORTH/PANHANDLE FLORIDA, SOUTH GEORGIA, MOBILE, ALABAMA

Zane Green  
Phone: 864-650-4259  
Fax: 904-212-0751  
zane.green@wilson.com

### SOUTHEAST NORTH CAROLINA, SOUTH CAROLINA, AUGUST & SAVANNAH, GEORGIA

Alan Johnson  
Phone: 843-992-6022  
Fax: 843-662-8447  
alan.johnson@wilson.com

### NORTHERN GEORGIA, NORTHERN ALABAMA

Craig Kalb  
Phone: 678-428-4489  
Fax: 770-837-0480  
craig.kalb@wilson.com

### VIRGINIA, EASTERN WEST VIRGINIA

Tim Kurtzweil  
Phone: 630-388-9728  
Office: 773-714-6828  
tim.kurtzweil@wilson.com

### CENTRAL GEORGIA, CENTRAL & SOUTH ALABAMA

Ken Weinhardt  
Phone: 678-643-2461  
Fax: 770-487-4121  
ken.weinhardt@wilson.com

## WEST

### REGIONAL SALES MANAGER

Steve Weisbrodt  
1554 Ashland Court NW  
Salem, OR 97304  
Phone: 503-805-5380  
Office: 503-363-8993  
Fax: 503-363-8981  
steve.weisbrodt@wilson.com

### UTAH, SOUTHERN IDAHO

Chase Hanchett  
Phone: 801-791-0709  
chase.hanchett@wilson.com

### SOUTHERN CALIFORNIA (SAN DIEGO, IMPERIAL, RIVERSIDE, SAN BERNARDINO COUNTIES), SOUTHERN NEVADA, HAWAII

Riley Jenkins  
Phone: 503-269-7619  
Fax: 877-865-0764  
riley.jenkins@wilson.com

### NORTHERN CALIFORNIA (CENTRAL VALLEY/BAY AREA), NORTHERN NEVADA

Matt Meier  
Phone: 515-257-7619  
Fax: 888-269-0972  
matt.meier@wilson.com

### ARIZONA, NEW MEXICO, WEST TEXAS

Rob Rusch Jr  
Phone: 480-433-1428  
Fax: 623-738-2139  
rob.rusch@wilson.com

### WASHINGTON, MONTANA, ALASKA, NORTHERN IDAHO

Scott Santschi  
Phone: 360-921-9989  
Office: 773-714-6400  
Fax: 425-939-8423  
scott.santschi@wilson.com

### OREGON, SOUTHERN WASHINGTON, NORTHERN CALIFORNIA (HUMBOLDT, SHASTA, SISKIYOU)

Kane Ten Pas  
Phone: 503-475-5003  
Office: 503-475-5003  
Fax: 503-747-7504  
kane.tenpas@wilson.com

### SOUTHERN CALIFORNIA (ORANGE, LA, VENTURE, SANTA BARBARA COUNTIES)

Rob Woidneck  
Phone: 619-618-6754  
Fax: 858-350-4709  
rob.woidneck@wilson.com

# WILSON TEAM SPORTS CORPORATION & DISTRIBUTION

### UNIFORM FACTORY

4600 Roberts-Matthews Hwy.  
Sparta, TN 38583  
Phone: 931-738-7500

### UNIFORM CUSTOMER SERVICE

Sparta: 800-468-8647  
Special Order Uniform  
Lead-Time Hot Line: 800-254-4433  
Fax: 800-537-0330

### DISTRIBUTION CENTER

2440 Couchville Pike  
Nashville, TN 37217  
Phone: 615-883-9133  
Fax: 615-883-9332

### CUSTOMER SERVICE

8750 West Bryn Mawr Ave.  
Chicago, IL 60631  
Phone: 800-245-5454  
Fax: 800-642-4600

### CREDIT

P.O. Box 31696  
Chicago, IL 60631  
Phone: 800-562-1900  
Fax: 773-714-4584

### CUSTOMER SERVICE

655 Spice Island Drive  
Sparks, NV 89431  
Phone: 800-800-9931  
Hours of Operation:  
8 am - 7 pm CST

### PRODUCTS & PARTS

Phone: 800-755-5100  
Hours of Operation:  
11 am - 7 pm EST

W, Wilson, A2000, A2K, Optic Yellow, Demarini, D, Louisville Slugger, LS, EvoShield, Atec, Super Z, C271, C243, M110, I13, T141, Omaha, Catalyst, Prime, CF, Insane, Voodoo, Armor, TPK, HI, Per, Tuffy, Xeno and Pro Stock are registered trademarks, and A200, A360, A500, Aura, Dual welting, Dura-core technology, EZ Gear, Flash, Guardian, New View, Select, Solo, Vapor, EvoArmor, JF12, AJ10, Y271, Y243, LXT, PXT, Rig, X-cap, TRU3, Stax, ISR, Dynasty, Genesis, Evocharge, Gel-to-Shell, M3, M2, M1, R3, R2, T3, Old School, Onyx, Pedrosa Fit, Prestige, Pro Gold, Pro Platinum, ProMotion, Quick Change, C1K, Siren, Slesk, Super seam technology, Super Skin, Big D, Bustos, C18, Corn dog, Stulsion, Digi Camo, Flipper, Fungoedic, Juggo, Lightning, Mercy, Momentum, Grind, Bullpen, Paradox, Paraflex, Phantom, Protégé, Shatter, Special Ops, Stone, Ultimate Weapon, Uprising, Vendetta, Pro Maple, CFK, Zen, Slapper, Stars & Bars, Dinger Slinger, GTS, New Breed, Enzo, Steel, Windy City, Mushball, Protusion, Gameday, Comotion, Fierce, Slesk, Evolite, Grandstand, Salute, Round tripper, Speed Stripe, Yard-work, Wilflex, Prostitch, T3, Custom Elite, Veteran, VIP, Heater and X-14 Alloy are trademarks of Wilson Sporting Goods Co.

NFHS is a registered trademark of the National Federation of State High Schools. MLB and Authentic Collection are registered trademarks of the Major League Baseball Properties, Inc. ASA is a registered trademark of the American Softball Association. USSSA is a registered trademark of the United States Specialty Sports Association. ISA is a registered trademark of the Independent Sports Association. Dri-lex is a registered trademark of Raytex Corp. SSUSA is a trademark of Senior Softball-USA. Little League is a registered trademark of Little League Baseball, Inc. Pony and the horse logo are trademarks of PONY Baseball and Softball. NOCSAE is a trademark of the National Operating Committee on Standards for Athletic Equipment.

Trademarks advertised other than those of Wilson Sporting Goods Co. are properties of their respective companies. NOTE: The display of logos in this catalog does not constitute an endorsement or sponsorship of Wilson merchants by the respective organization.

facebook.com/WilsonBaseball  
facebook.com/DemariniSports  
facebook.com/LouisvilleSlugger

@WilsonBaseball  
@DeMarini  
@SluggerNation

@WilsonBaseball  
@DemariniFP  
@DemariniNation  
@SluggerNation

Wilson Ball Gloves  
DeMarini Sports  
Louisville Slugger

USERNAME:

PASSWORD:

ACCOUNT NO:

# B2B

URL: <https://sales.wilson.com>

# Wilson

wilson.com

©2017 Wilson Sporting Goods Co.  
All Rights Reserved Printed in USA  
16-2628/20M/417  
WTCATL018SPDEAL







THE OFFICIAL BASEBALL GLOVE, BAT, PROTECTIVE GEAR & TRAINING EQUIPMENT OF MAJOR LEAGUE BASEBALL

